

# Adjustable Speed Drive Motor Protection Applications and Issues

Jon Gardell, Chairman    Prem Kumar, Vice Chairman

**Members of the Working Group are: Munnu Bajpai, Matt Basler, Mike Bloder, Stephen Conrad, Terry Crawley, Tom Farr, Everett Fennell, Dale Finney, Dale Frederickson, Adrian Guggisberg, Wayne Hartmann, Pat Kerrigan, Hardy King, Federico Lopez, Joshua Park, Subhash Patel, Mike Reichard, Chris Ruckman, Sudhir Thakur, Joe Uchiyama, Sahib Usman.**

## Abstract

The uniqueness of the electrical environment (asynchronous connection to power system, variable frequency operation, and harmonics) on the output of adjustable speed drives (ASDs) requires special consideration to be given to the motor protection. The Working Group has investigated and addressed these concerns. This paper reports the findings of this activity and makes recommendations to the motor protection engineer.

## Introduction

This paper provides the background and a basis for guidance with regard to protecting motors connected to ASDs. This paper does not cover the specifics of all drive technologies for motor applications due to the large number of types and technologies. The intent is to provide guidance to the protection application engineer to implement adequate motor system protection given the special conditions.

ASDs have been widely used in industry for many years. The Rotating Machinery Protection Subcommittee of the IEEE Power System Relaying Committee believed that prior to revising the IEEE Guide for AC Motor Protection, this equipment and its impact on motor protection applied external to the ASD should be investigated. Manufacturers of ASDs have provided motor and drive protection functions in their system controls and some have suggested that additional external protection for the motor and system is not required. The Subcommittee wanted to better understand this technology and have a clearer position on appropriate protection.

## Contents

I. Overview .....	2
II. Definitions .....	3
<b>III. History of Application and Purpose of Adjustable Speed Drives (ASD) .....</b>	<b>6</b>
<b>IV. ASD and Motor System Description .....</b>	<b>6</b>
<b>V. Content Coverage in C37.96-2000 – Sub clause 6.3.1 .....</b>	<b>12</b>
<b>VI. Changes to Motor Operating Characteristics and Dynamics that can Impact Protection .....</b>	<b>13</b>

<b>VII. Motor, System, and ASD Protection Issues .....</b>	<b>15</b>
<b>VIII. Protection Commonly Included in the Drive System.....</b>	<b>18</b>
<b>IX. Conclusion and Next Motor Guide Revision.....</b>	<b>19</b>
<b>X. Bibliography .....</b>	<b>31</b>
<b>Annex A - Nuclear Recirculation Pump Motor Application Summary.....</b>	<b>32</b>
<b>Annex B - Manufacturer A’s ASD Protection Example.....</b>	<b>35</b>
<b>Annex C - Manufacturer B’s ASD Protection Example.....</b>	<b>37</b>
<b>Annex D - Harmonic data from a large ASD Motor .....</b>	<b>39</b>

**I. Overview**

**A. Scope**

The scope of this document consists of the following:

1. Overview
2. Definitions
3. History of Application and Purpose of Adjustable Speed Drives (ASD)
4. Present Coverage in C37.96-2000 – Sub clause 6.3.1
5. Changes to Motor Operating, Characteristics and Dynamics that can Impact Protection
6. Motor, System and ASD Protection Issues
7. Protection Commonly Included in the Drive System
8. Conclusion and Next Motor Guide Revision – Resolutions for Adequate and Complete ASD Motor-Drive System
9. Annex
  - A. Case Study 1 – Nuclear Recirculation Pump Motor Application Summary
  - B. Manufacturer A –Protection Application Example – Pulse Width Modulated Drive
  - C. Manufacturer B –Protection Application Example – Pulse Width Modulated Drive
  - D. Measured Harmonics on the Output of an ASD.
10. Bibliography

**B. Purpose**

This Working Group assignment is to provide a recommendation to the Rotating Machinery Protection Subcommittee of the IEEE Power System Relaying Committee regarding protection requirements of motors applied with Adjustable Speed Drives (ASDs). The recommendation will be incorporated into the next revision of C37.96 – IEEE Guide for AC Motor Protection. This paper presents the results of the Working Group J1 investigation based on industry knowledge, experience, literature, current drives projects, and knowledgeable guest speakers.

## **II. Definitions**

### **Adjustable Speed Drive**

A drive designed to provide easily operable means for speed adjustment of the motor within a specified speed range. – [B13]

### **Drive**

The equipment used for converting electrical power into mechanical power suitable for the operation of a machine. A drive is a combination of a converter, motor, and any motor mounted auxiliary devices. Examples of motor mounted auxiliary devices are encoders, tachometers, thermal switches and detectors, air blowers, heaters, and vibration sensors.

### **Converter**

A machine or device for changing AC power into DC power (rectifier operation) or DC power into AC power (inverter operation). Other types of converters can change AC power directly to an AC power of a different frequency (Cyclo Converter)

### **Inverter**

A converter in which the direction of power flow is predominately from the DC terminal to the AC terminal. – [B13]

### **Current Source Inverter (CSI)**

An inverter, in which the DC terminal is inductive and, as a consequence, the DC current is relatively slow to change. Modulation of the CSI acts to control the voltage at the AC terminal. The switches in a CSI must block either voltage polarity, but are only required to conduct current in one direction.

### **Voltage Source Inverter (VSI)**

An inverter in which the DC terminal is capacitive and, as a consequence, the DC voltage is relatively stiff. Modulation of the VSI acts to control the current at the AC terminal. The switches in a VSI must block DC voltage, but be able to conduct current in either direction.

### **Current-Source Converter**

A current source converter is characterized by a controlled DC current in the intermediate DC link. The line side network voltage is converted in a controlled DC current. A current source converter always uses an SCR bridge or an active front end to control the DC current.

### **Voltage-Source Converter**

A voltage source converter is characterized by a stiff DC voltage in the intermediate DC-link. The line side network voltage is converted to a constant DC voltage. A voltage source converter uses a diode bridge (6 pulse, 12 pulse, 18 pulse, 24 pulse or 36 pulse) or an active front end to connect the DC-link to the network voltage.

## **Harmonic**

A sinusoidal component of a periodic wave or quantity having any frequency within the spectra.

There are three basic classes of harmonics:

- Frequencies with an integer multiple of the fundamental frequency.
- Frequencies with a non-integer multiple of the fundamental frequency (inter-harmonics)
- Frequencies that are below the fundamental frequency (sub-harmonics).

## **Commutation**

The transfer of current from one switching device to another. Line-commutation utilizes the AC system voltage for the transfer of current from one device to another.

Self-commutation is achieved by utilization of the turn-off switching capability of devices such as an Insulated Gate Bipolar Transistor (IGBT) / Gate Turn-Off Thyristor (GTO) or Gate Controlled Turn-Off Thyristor (GCT). These devices can interrupt a current. The interruption forces the current to flow through another device.

## **Active Front End**

An active front end is a self commutated converter, which is used to connect the network voltage to the DC-link.

## **Pulse Width Modulation (PWM)**

A control method for a converter wherein the control of the frequency and magnitude of the output voltage or current is accomplished by variation of the operating duration of the switching devices (duty cycle of turn on and off). This method is typically used to control a self commutated converter. – [B13]

## **Silicon Controlled Rectifier (SCR)**

A solid-state switching device with three terminals: an anode, a cathode and a gate (also known as a thyristor). The SCR will conduct electricity when the anode has a positive potential with respect to the cathode and a pulse is applied to the gate. The SCR will continue to conduct until the potential difference between the anode and cathode is reduced below a certain threshold value. SCRs can only be switched on. The switch off occurs when the current changes direction in the SCR.

## **Pulse Number**

The pulse number of a converter defines the number of commutations, which are used within one fundamental period, to convert AC to DC. The basic converter for a three phase system is a B6 topology.

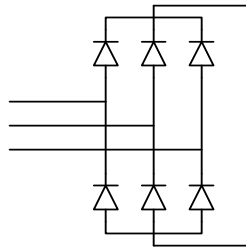

**Figure 1: B6 Converter**

The B6 converter uses 6 commutations within one fundamental period. This results in a commutation every 60 degrees.

Common Pulse Numbers:

6 pulse	base on 1 B6 circuits
12 pulse	base on 2 B6 circuits
18 pulse	base on 3 B6 circuits
24 pulse	base on 4 B6 circuits
36 pulse	base on 6 B6 circuits

### **Bypass Contactors**

Bypass Contactors are often used with Drive systems. There are two reasons for bypass. The most common is for maintenance purposes. If the drive must be out for maintenance, the bypass contactor is closed to allow the motor to run across-the-line (ATL). The second reason is to allow the drive to bring one motor to full speed and then switch to another motor. This allows the user to have one drive for many motors.

When the motor is in bypass the drive is typically no longer providing motor protection. Appropriate motor protection per C37.96-2000 should be used until the motor is transferred back to the ASD.

### **CLE Fuses – current limiting element**

Medium Voltage type CLE fuses are sometimes used in the primary of the isolation transformer. CLE fuses offer current-limiting short circuit protection

### **Field Weakening Range**

Defines when a motor is operated at a speed above its nameplate RPM, the drive must hold nameplate voltage while increasing the frequency thus weakening the rotor field (air gap flux). This is also known as the constant horsepower range.

### **Reference Sources**

1. [B13] “The Authoritative Dictionary of IEEE Standards Terms” C37.100 [IEEE-100]
2. Hingorani, Gyugyi “Understanding FACTS”
3. NEMA Standards Publication, “Application Guide for AC Adjustable Speed Drive Systems”

### **III. History of Application and Purpose of Adjustable Speed Drives (ASD)**

Various forms and technologies of drives have been applied in industry for many years. Varying speed using DC Motors for process control has been applied since the very early days of electric motors. AC Drives have been used since the early 20<sup>th</sup> Century on a limited basis. The principles applied for varying speed have been well understood by motor designers and application engineers but the advent of power electronics is what fostered this application of technology.

Two key benefits of using ASDs are improved process control and efficiency. Due to the mechanical affinity laws in a centrifugal pump or fan application, the process flow is directly proportional to speed and mechanical horsepower is directly proportional to the cube of speed. Therefore, for a centrifugal load driven at 50 percent speed (flow) only 12.5 percent of the mechanical horsepower is required.

Other benefits derived from applying adjustable speed drives are the following:

- Soft-Start Capability
- Short Circuit Reduction
- Replacement of Older Process Control Technologies

These benefits may be important from an operational and design point of view. For example a system using larger horsepower motors will not be burdened with the traditional negative impacts such as large inrush currents, and excessive short circuit contribution, etc. In some system applications it may be possible to add more motors and horsepower capacity without exceeding the voltage drop limits for motor starting and short circuit ratings of the associated breakers.

ASDs are ideal on loads where torque increases with speed, such as fans, blowers, centrifugal pumps, and most kinds of compressors. Constant-torque loads require the same torque regardless of speed such as reciprocating compressors, positive-displacement pumps, conveyers, center winders, and drilling/milling machines. ASD must be carefully sized to ensure adequate starting torque for those applications. Loads in which torque decreases with speed usually involve very high inertia loads such as vehicular (drives or flywheel) loaded applications. Custom-engineered solutions are often required for those applications.

### **IV. ASD and Motor System Description**

The ASD system can be categorized by various criteria. The following section gives an overview of different criteria.

All ASDs have the same basic structure, which includes a rectifier, filter, and inverter. The rectifier converts three-phase AC line power to DC power. The components used in the rectifier are typically thyristors or diodes. The dc link sits between the rectifier and inverter. It provides harmonic and power ripple filtering (using inductors or chokes) as well as power storage (using capacitors). These components work to smooth and regulate,

respectively, the current and voltage supplied to the motor. The inverter portion typically consists of thyristors or transistors that are carefully controlled to sequence the proper voltage and current to the phase windings of the motor, depending on the speed and load required.

In order to define the proper protection scheme, it is essential to categorize the ASD system.

### **Categorization by load type**

The following basic types can be distinguished:

- Variable torque load, typically torque increases by the square of speed
- Typical applications are fans, pumps, centrifugal compressors
- Constant torque applications, typically torque is constant over the speed range
- Typical applications are conveyors, reciprocating compressors, paper mills, rolling mills

### **Categorization by the ASD topology - system configuration**

The following basic types can be distinguished:

- Stand alone ASD
- ASD with manual bypass (motor can be operated in an across the line start configuration (ATL))
- ASD with synchronized bypass (ASD can synchronize the motor to the line and back to the drive)
- ASD with more than one motor connected to one single drive
- Multi motor ASD system (Multidrive). A common DC-link is used for several inverters to drive several motors

### **Categorization by operation area**

The following basic types can be distinguished:

- 1q, 2q or 4q operation
  - 1q operation means: the motor runs only in one direction and only in one mode (either as motor or as generator)
  - 2q operation means: the motor runs in both direction, but only in one mode (either as motor or generator)
  - 4q operation means: the motor runs in both directions and in both modes. This requires either an active front end or dynamic braking.
- The motor is operated in field weakened range. (see definition)
- The motor is operated continuous in low speed operation (0Hz – approx. 5Hz)

The motor is operated at high speeds (in excess of approximately 100Hz)

### **Categorization by ASD topology**

The basic blocks of an ASD system are shown in the following figure.

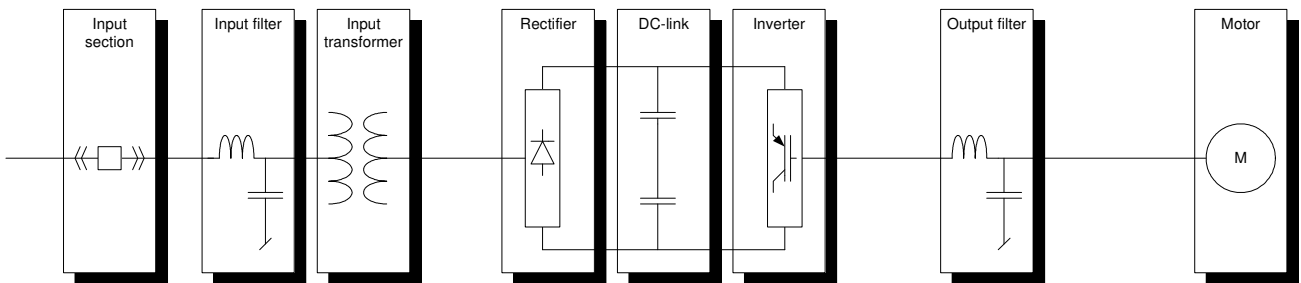

**Figure 2: Basic blocks of an ASD system**

All blocks shown above are not necessarily needed for an ASD system. Depending on the topology, some blocks are required and some not. Below is a short explanation of each basic block.

**Input section:**

The input section provides isolation of the ASD from the main supply. Typically it provides also the last level of protection.

**Input filter:**

The input filter is used to limit the harmonic currents induced to the network and improve displacement power factor. A harmonic filter is usually used in conjunction with an active front end or a current source inverter.

**Input transformer:**

The input transformer has typically two basic functions. The transformer provides a multi-winding secondary system in order to connect a rectifier with a pulse number greater than six. For example a 12 pulse rectifier requires at least a 3 winding transformer, or a 36 pulse rectifier requires at least a 7 winding transformer.

The transformer also provides galvanic separation of the ASD system from the network. Specifically the zero sequence or common mode voltage can be isolated between the network and the motor.

**Rectifier:**

The rectifier for a VSI (voltage source inverter) is typically built up by a diode rectifier. For LV (Low Voltage) ASD systems, a 6 pulse rectifier or an active front end are very common. For MV (Medium Voltage) ASD systems a 12 pulse rectifier meets in most cases the network harmonic limit requirements defined in IEEE 519. However for higher power ASD systems (typically above 5000HP) pulse numbers greater than 12 are very common. The rectifier for a CSI (current source inverter) is built up by an SCR rectifier. Typical pulse numbers are between 6 pulse and 24 pulse. However, since in most cases an input filter is required to meet the harmonic limits defined in IEEE 519, 12 pulse configurations are very common. In case SCR's are used in the rectifier, the power factor of the rectifier is, at certain operation points, very poor. The power factor is basically

equal to the firing angle of the SCR. Therefore, the harmonic filter is also used for power factor compensation.

**DC-link:**

The DC-link is used to decouple the line side converter (rectifier) from the motor side converter (inverter). In ideal case the intermediate DC link provides infinite energy storage to filter all harmonics, which can couple effects from each side to the other. A VSI converter uses a capacitor bank to decouple both sides, where a CSI uses an inductor to decouple both sides. Both elements provide energy storage and act as filters.

**Inverter:**

The inverter is also called the motor side converter and is used to convert DC to AC. The inverter is the most advanced block in an AC ASD system. There are many different inverter topologies. The most common topology is a 2-level inverter. This topology is widely used for all kind of LV ASD systems. CSI converters are also based on a 2-level inverter. Especially for MV ASD systems higher levels of inverter configurations are built.

The following figure shows the principle of the inverter levels.

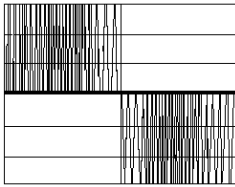

Two Level PWM

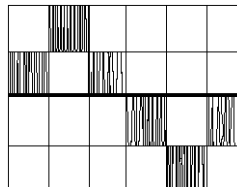

Three Level PWM

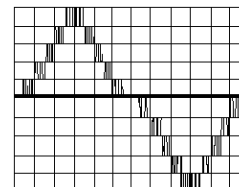

Five Level PWM

**Figure 3: Inverter Levels**

- Case 1 shows a 2-level inverter. The output of this inverter can be switched to 2 different levels: DC plus and DC minus.
- Case 2 shows a 3 level inverter. The output of this inverter can be switched to 3 different levels: 0, DC plus and DC minus.
- Case 3 shows a 5 level inverter. The output of this inverter can be switched to 5 different levels: 0, DC plus, 2 \* DC plus, DC minus and 2 \* DC minus

**Output filter:**

An output filter is used in order to smooth the output waveform. Especially for VSI topologies an output filter is used to limit the voltage rise time or even eliminate all major harmonics.

**Motor:**

The motor is always used in order to convert the electrical energy into mechanical energy.

The following table gives an overview about the most common topologies and the characteristics:

Topology	Characteristics	Typical minimum requirements
DC Drive	The ASD uses a DC motor. This was historically the first topology for ASD systems. Today it is only used in special applications, such as drilling.	<ul style="list-style-type: none"> <li>- Input section</li> <li>- SCR – Rectifier</li> <li>- DC motor</li> </ul>
LCI (Load Commutated Inverter)  Line commutated Current Source Inverter (CSI)	The LCI is a commonly used CSI topology. The LCI uses SCRs on the line side to control the DC current and uses SCRs on the motor side to control the speed of the motor. LCI's are used for gas turbine starters or large drive systems > 20,000HP.	<ul style="list-style-type: none"> <li>- Input section</li> <li>- Input filter</li> <li>- Input transformer</li> <li>- SCR rectifier</li> <li>- DC link with inductor</li> <li>- SCR inverter</li> <li>- Synchronous motor</li> </ul>
Self commutated CSI	The self commutated CSI doesn't use SCRs at the motor side. This topology uses a semiconductor, which can be turned off as well. Since the CSI acts as a 2-level inverter, it creates significant output harmonics. Therefore this converter type is usually equipped with a large output filter. Typically Symmetric Gate-Commutated Thyristors (SGCTs) are used for self commutated CSIs. The line side converter can be based on SCRs or SGCTs.	<ul style="list-style-type: none"> <li>- Input section</li> <li>- Input filter</li> <li>- Input transformer (for SCR rectifiers)</li> <li>- SCR or SGCT rectifier</li> <li>- DC link with inductor</li> <li>- SGCT inverter (2 level)</li> <li>- Sine wave output filter</li> <li>- Motor</li> </ul>
2-level VSI	A 2-level VSI topology is the most common topology for LV ASD systems. Most LV ASD systems are based on a 2-level VSI topology with a 6 pulse diode rectifier.	<ul style="list-style-type: none"> <li>- Input section</li> <li>- Input filter</li> <li>- Electromagnetic Compatibility (EMC)</li> <li>- Rectifier, 6 pulse diode bridge</li> <li>- DC link with capacitor</li> <li>- Inverter (Transistor or Insulated Gate Bipolar Transistor (IGBT))</li> <li>- Output filter (EMC)</li> <li>- Motor</li> </ul>

<p>3-level VSI</p>	<p>The 3-level VSI topology is the most common topology for MV ASD systems for high performance. Such VSI systems are built up to 40,000HP and are widely used in metals industry, where performance and reliability is very important. Dependent on the application this topology is equipped with a multi pulse rectifier or an active front end rectifier.</p> <p>Since the voltage steps on the output are relatively large, an inverter duty motor is required for the ASD system, unless an output filter is provided to reduce the harmonics.</p>	<ul style="list-style-type: none"> <li>- Input section</li> <li>- Input transformer</li> <li>- Diode rectifier (12 pulse or 24 pulse) or active front end</li> <li>- DC link with capacitor</li> <li>- 3-level inverter</li> <li>- Output filter (EMC) or sine wave</li> <li>- Motor</li> </ul>
<p>Multi level VSI</p> <p>Typically VSIs with 5 levels and more.</p>	<p>A multi level VSI provides more than three basic steps in the output voltage waveform. It is considered that such an inverter can be connected to a standard motor without requiring derating of the motor due to current harmonics induced to the motor. Multi level VSIs are equipped with a multi pulse rectifier and always require an input transformer.</p>	<ul style="list-style-type: none"> <li>- Input section</li> <li>- Input transformer</li> <li>- Diode rectifier (18 pulse, 24 pulse or 36 pulse)</li> <li>- DC link with capacitor</li> <li>- Multi-level inverter</li> <li>- Output filter EMC</li> <li>- Motor</li> </ul>

**V. Content Coverage in C37.96-2000 – Sub clause 6.3.1**

Figure 4 shows the Variable Frequency Drive (ASD) Relay One-Line presented in the present IEEE Guide for AC Motor Protection

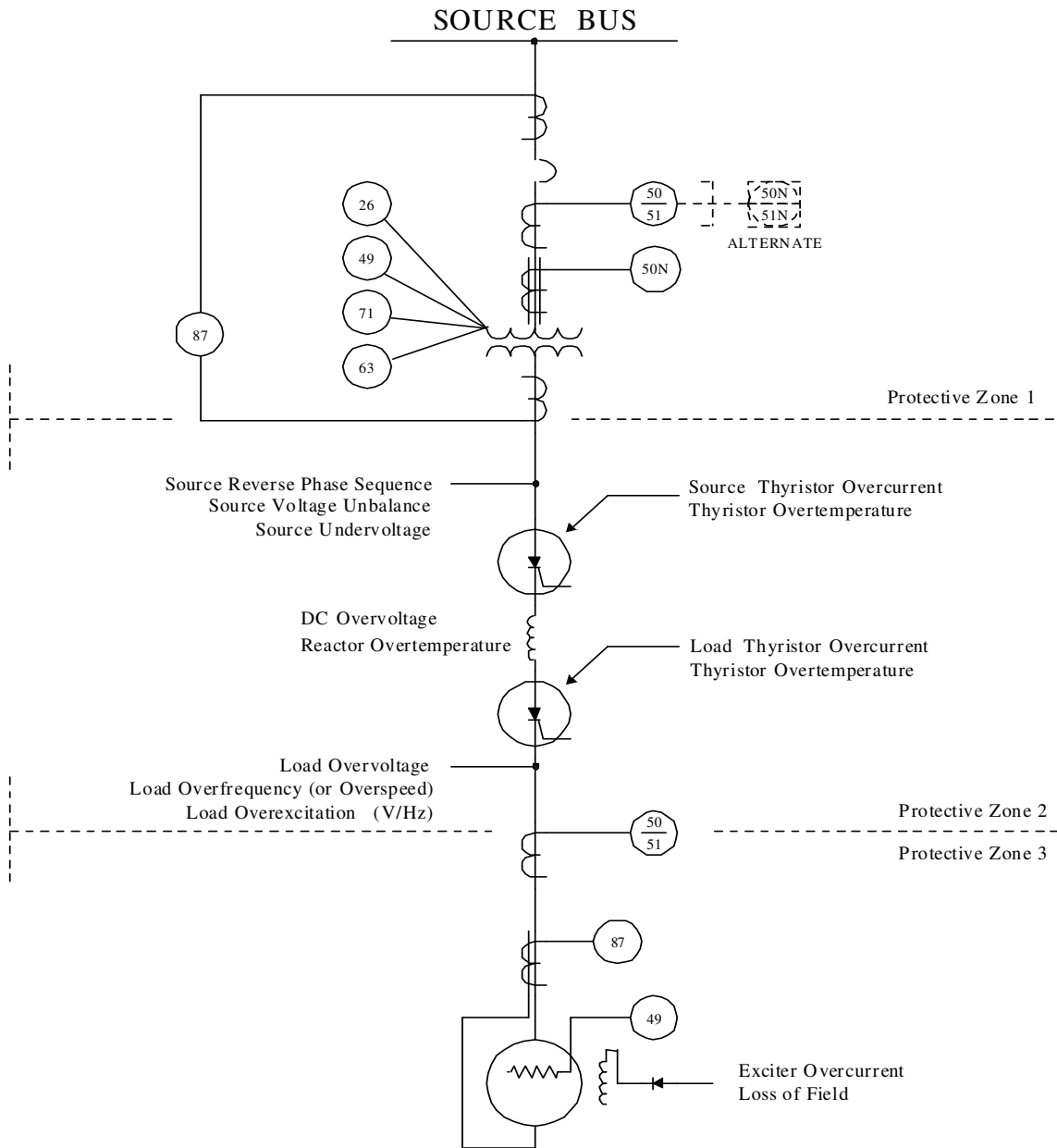

**Figure 4 -Variable frequency drive protection**

C37.96-2000 addresses the protection of motors applied with medium voltage adjustable speed drives. The drive system protection is divided into three zones of protection:

### **Zone 1 - Input transformer**

Primary overcurrent protection, in addition to normal application requirements, should allow for motor acceleration. Differential protection may be provided on large/critical drive systems but may have limited effectiveness for ground faults on resistance grounded supply systems. The drive system usually includes integral secondary circuit ground fault protection which typically employs zero sequence voltage detection for ungrounded transformer secondary connections and residual or neutral overcurrent for grounded wye secondary connections.

### **Zone 2 - Power electronics (Drives Equipment)**

The drive system typically monitors input and output voltages and will alarm and/or trip for over or under voltages and voltage unbalances. Some drives may also include DC link reactor overvoltage protection. Overcurrent protection is provided for the converter electronics and interconnected bus or wiring. Current levels are limited to acceptable levels by control action and the drive is tripped if current is above these levels for a preselected time. Short circuit protection is provided by fuses ahead of the thyristors. Additional protection may be supplied by monitoring the temperature of the drive and cooling medium. If a link reactor is used it may also have temperature monitoring and trip settings.

### **Zone 3 – Motor**

Motors should be provided with the same protection as constant speed motors of the same size. Motor protection should also include overfrequency and overvoltage or overexcitation protection. This protection is typically provided by the drive control system but could be provided by discreet or multifunction relays.

Bus Connected Drive Systems (no isolation transformer) are also discussed. With this connection, short circuit coordination between the relay on the supply breaker and the drive overcurrent protection may be difficult. If high speed clearing of faults is desired, some loss of coordination may occur.

## **VI. Changes to Motor Operating Characteristics and Dynamics that can Impact Protection**

When motors are applied to ASDs, certain operating characteristics of the motor are modified. The operating frequency impacts how the motor behaves during operation both starting and running as well as during abnormal operation and fault conditions. The areas that will be discussed are pertinent to the protection of the motor and drive system.

The following characteristics are pertinent to the protection of the motor:

### **A. Motor Ground Fault Conditions - Two cases should be distinguished:**

- ASD with input transformer. The input transformer provides galvanic isolation between the motor / ASD and the feeder bus. A ground fault on the motor / ASD will not influence the ground fault protection of the feeder bus.

- ASD without input transformer. There is no galvanic isolation between the motor / ASD and the network in this configuration. A ground fault on the motor may trigger the ground fault protection on the feeder bus. It is recommended to check the ground fault protection scheme of the ASD with the manufacturer to assure selectivity of the ground fault protection scheme (ASD ground fault protection should trip faster than the feeder bus ground fault protection).

B. Motor Fault Contributions When a drive is applied to a motor it provides a current limiting feature such that it will limit the contribution to the system short circuit level. In some cases the contribution to short circuit can be eliminated by switching the power electronics in the drive such that any short circuit current contribution from the motor will not flow back to the point of fault in the system. This is a significant benefit with regard to a large motor with a long short circuit time constant when considering limits on the system breakers for fault duties.

C. Soft Starting ASDs limit and control motor starting current by the appropriate firing of the power electronics. This capability is known as “soft starting”.

D. Reduced Frequency Operation Effects The frequency of the source to the motor dictates the operating speed. At lower speed operation the motor is not cooled as efficiently as it is at rated speed. Therefore this must be taken into consideration with regard to motor thermal overload protection. For constant torque applications, auxiliary motor cooling may be required. Actual motor full load current (FLA) is a function of the frequency, as lower FLA is drawn at lower frequency. The Actual FLA must be used in the overload protection. This is particularly important for a sustained motor operation at off-nominal frequency. Note that motor manufacturers typically state Rated FLA at nominal frequency. Also it is important for the protective device to accurately measure motor current at off-nominal frequencies (by frequency tracking or other means) to provide effective overload protection at all frequencies.

E. Harmonics Harmonics in the motor current will cause additional heating in the motors and other connected elements. This additional heating needs to be considered when sizing and protecting the equipment. At near rated load, a typical value to accommodate the additional heating can be up to 15 percent increase above the fundamental heating effects. Refer to NEMA MG-1 for further details or derating factors. Auxiliary cooling may be considered for constant torque applications.

F. Flux levels State of the art control algorithms used in ASDs, keep the motor flux constant over the entire speed / frequency range. This results in a V/f characteristic shown in figure 5. The voltage is proportional to the frequency ( $V/f = \text{constant}$ ) in the upper frequency range. In the lower frequency range, the voltage is not proportional to the frequency. An extra voltage boost is applied to compensate the voltage drop over the stator resistance of the motor. This characteristic should be considered in sizing CTs and VTs.

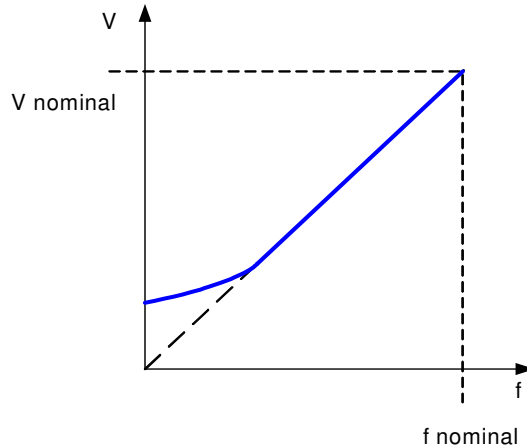

**Figure 5: Typical V/f curve of an induction motor**

G. Voltage and Dielectric Stresses Consideration should be given for overvoltage protection due to the potential for this condition and the fact that many drives operate at fairly high semiconductor switching frequencies. The concern is especially important with drives applied on long cable runs that can have high voltages developed due to cable capacitance. Sustained overvoltage conditions can be detected by overvoltage protection functions but the ringing effect must be mitigated by other voltage control methods.

## **VII. Motor, System, and ASD Protection Issues**

### A. Zone 1 Protection Issues

The feeder breaker supplying the ASD typically is equipped with overload and short circuit protection for the input transformer and / or the drive electronics. Typically, a phase time overcurrent element (51) is applied for overload protection and an instantaneous overcurrent element (50) is applied for short circuit protection. A 51 element that operates on the fundamental frequency (i.e. not rms) may be set with a lower pickup, as it will not respond to the harmonic components of the load current. If there is an isolation transformer, the 50 element is typically set with a pickup of 140% of the transformer secondary through-fault current and above the transformer inrush current. In cases where the drive employs an active front end, the 50 element can be set lower as the drive normally limits the starting current to less than two times rated. An instantaneous ground element (50N) can be applied to give more sensitive protection for ground faults. Occasionally, a differential relay has been applied to the primary feeder to provide high speed tripping for faults up to the transformer high-side winding.

Differential protection for large isolation transformers can be considered only when it is practical. For large ASD applications, the ASD isolation transformer typically has multiple secondary windings (Annex A transformer has 15 secondary windings). In those cases it is not practical to have conventional differential protection. The feeder 50 can then be relied upon to provide high speed protection for the isolation transformer primary windings. Relays which mitigate DC offset currents should be selected to allow

for the 50 element to be set as sensitive as possible. The feeder 51 can provide conventional time delayed protection. For multiple secondary winding configurations the feeder 51 may not provide protection for secondary winding faults. The drive integral protection would protect those faults. In some cases, the drive integral protection includes a power differential that compares the transformer input and drive output power.

Where isolation transformers are used which have not been specifically designed for harmonic loading, ANSI/ IEEE C57.110, “Recommended Practice for establishing Transformer Capability when Supplying Non-sinusoidal Load Currents” may be used to apply transformer de-rating factors for each harmonic. Devices exist that will provide thermal protection based on this guide.

There may be additional protection applied for faults on the secondary side of the isolation transformer. This may include a zero-sequence voltage detection circuit if the transformer secondary is ungrounded or a residual or neutral overcurrent for a grounded wye secondary connection. Some ASD manufacturers employ fuses for transformer through-fault protection.

In addition to providing protection, there are other Zone 1 protection aspects that may need to be reviewed when there is an ASD on a bus. This is especially true in retrofit applications.

1. The short circuit contribution from the drive to any fault on the bus or another feeder is typically negligible due to the current limiting action of the drive controls as mentioned previously.
2. If a large motor, especially one associated with a high inertia load such as a fan, is retrofitted with ASD, the residual voltage on the bus during high-speed bus transfer may be less than before the retrofit. This may result in an unsuccessful transfer or possible damage to other motors connected to the bus. Unless special control action, such as the use of a regenerative drive is implemented, the high inertia load will no longer contribute to keeping the bus voltage frequency up during transfer. In addition, the drive electronics will most likely draw extra vars from the bus, depressing the voltage further. Consult the ASD manufacturer.
3. If there are capacitors on the bus feeding the ASD, such as power factor correction capacitors, resonances can occur which can be damaging to electrical equipment on the system. Capacitors located between the drive output and the motor terminals should be avoided.

#### B. Zone 2 Protection Issues:

Components internal to the ASDs are typically well protected by the manufacturer and do not require additional protection consideration. Zone 2 equipment protection is beyond the scope of this paper. Please see Annexes for Manufacturers’ examples.

### C. Zone 3 Protection Issues:

ASD manufacturers typically integrate most of the required Zone 3 protection within the ASD internal electronics (See Section VIII). Supplemental motor protection such as over current protection and flux balance/differential protection (for large motors) may be considered. If applied, however, the off-frequency characteristics of the individual components comprising the supplemental protection should be carefully scrutinized. In particular, attention should be given to the low frequency saturation point of current transformers and the low frequency response characteristics of protective relays placed downstream of the ASD. Because of issues surrounding these components, many ASD manufacturers do not recommend supplemental motor protection and warn of inadvertent tripping when they are used.

If supplemental motor protection is used with the ASD system, the following items should be considered.

#### **Overcurrent Protection**

In conventional motor protection, overcurrent curves are set to protect a motor based on its thermal limit curves. Time overcurrent curves are typically set below and to the left of these motor limit curves and above the acceleration curve to allow the motor to successfully accelerate.

Modern microprocessor based motor protection relays have thermal models which approximate the heating effects that various system conditions have on the stator and rotor. However, these thermal models rely on motor thermal damage curves limits which are typically reported by motor manufacturers at only nominal frequency 60Hz. Unless the motor thermal limits are known over the operating frequency range of the ASD, it may be difficult to fully utilize the thermal model available in many modern motor protective relays.

If the thermal model cannot be used, it may be more practical to use simple overcurrent relaying to provide motor overload protection. Either way, in this application, select a pickup based on motor FLA (corresponding to maximum operating frequency which will be close to nominal frequency). This will then provide overload current protection when the motor is operating at or near the maximum operating frequency but will provide reduced protection at lower frequencies.

If motor thermal limits are available at various frequencies, an alternate approach might be to implement adaptive characteristics which would provide full overload protection at all settings where different overcurrent curves are selected based on motor frequencies. Each overload curve would be applied to a band of frequencies and would be set to match the thermal limits of the motor at the upper range of the frequency band.

#### **Differential Relay**

For large motors, differential protection is recommended and can be provided by flux balance CTs. The sub nominal frequency characteristics of both the CTs and the differential relay should be verified as adequate for the application.

### **Ground Protection**

The drive side of the isolation transformer typically has multiple secondary windings that are ungrounded, thus dedicated ground fault protection may not be practical. The drive manufacturer provides internal ground fault protection to detect load side ground faults. External motor ground fault option is typically not required unless the motor can also be started or operated across line (bypassing the ASD).

### **CT/Relay Harmonics**

Care should be taken to select CTs which will not saturate over the expected operating frequency range of the ASD. The CT performance at low frequency/high harmonic should be evaluated. At reduced frequencies the CT capacity is correspondingly reduced, e.g. at 10% frequency the CT capability is about 10%. However the drive-side fault current is relatively small (because of isolation from AC system). Therefore, the CT only has to be designed for motor contribution currents (relatively small currents). The relay performance at higher harmonics should also be verified as the harmonics at low currents can be considerable. The use of a higher ratio CT (5 times nominal rating) and a lower nominal current relay (1 amp relay a 5 amp relay) would be an option to enhance overall CT/relay performance. The settings would have to be appropriately adjusted for those conditions.

See the table in Annex D for harmonics encountered on a large ASD motor application, the harmonics are especially high at low frequencies. This data is from actual test measurements for the large motor application in a power plant.

## **VIII. Protection Commonly Included in the Drive System**

Various protection elements are included in ASDs yet the types of protection included varies from manufacturer to manufacturer. The protection can be broken down into three major categories, line side protection (Zone 1), system level protection (Zone 2) and load side protection (Zone 3). The following is the protection most commonly included in ASDs:

### Line Side Protection (Zone 1)

- Short Circuit/Overcurrent – some are protected with a fuse, circuit breaker, or protective relay overcurrent function
- Overload – overcurrent protection with time delay
- Voltage Unbalance – loss of input phase
- Ground Fault Overcurrent

### System Level Protection (Zone 2)

- DC Overvoltage

- DC Undervoltage - loss of control power
- Over Temperature – this includes the rectifier and inverter heat sinks as well as the enclosure temperature

#### Load Side Protection (Zone 3)

- Ground Fault
- Motor Overcurrent
- Motor Overload  $I^2t$
- Motor Stall
- Motor Overspeed
- Current Unbalance
- Underload – may indicate a process malfunction and will protect the machinery and the process in this fault condition
- External Fault – an external relay input

Typically ASDs offer a current limiter and torque limiter function. These functions can be programmed in order to keep the current and / or the torque at a maximum allowed limit. In case the current or torque demand from the process or speed controller exceeds the current / torque limit, the actual speed is limited and the current / torque is kept below the limits. This function can be used to limit the current to the motor.

Although the protection above is commonly found in most manufacturers of ASDs their implementation of that protection may vary. Some manufacturers supply other protection within the ASD such as:

- Line Overvoltage
- Line Undervoltage
- DC Overcurrent

### **IX. Conclusion and Next Motor Guide Revision**

In summary, the Working Group has provided a basis for guidance to apply adequate protection to motors connected to adjustable speed drive systems. In this section, example figures 6 through 15 present recommended protection for consideration for various motor and ASD types.

This document should be given careful consideration for the next revision of C37.96. Of particular importance is the inclusion of the protective function, not necessarily its physical location in an external protection system or the drive controls. It is clear based on the group's work, that many application engineers lack a thorough understanding of ASD Motor protection. There are many unique protection scenarios that may require discussion between the protection engineer and the drive manufacturer.

The Annex A contains a sample application including the required data and chosen settings. The Annex B and C also include, generically, two manufacturers' ASD protection complements. Annex D contains sample harmonic data.

The Working Group would like to thank all of the contributors to this effort both within and outside the IEEE Power System Relaying Committee.

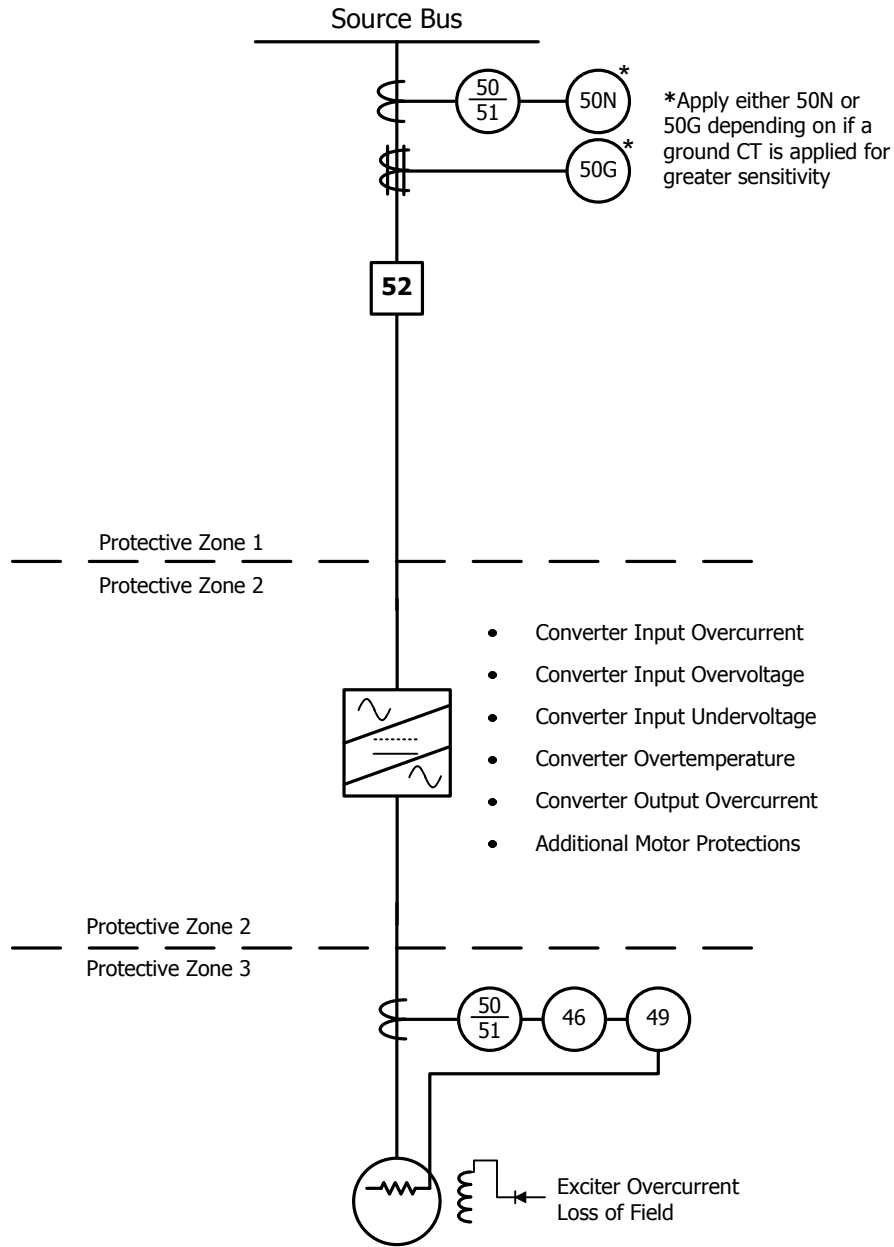

Figure 6: Synchronous Motor, No Transformer, No Motor Differential

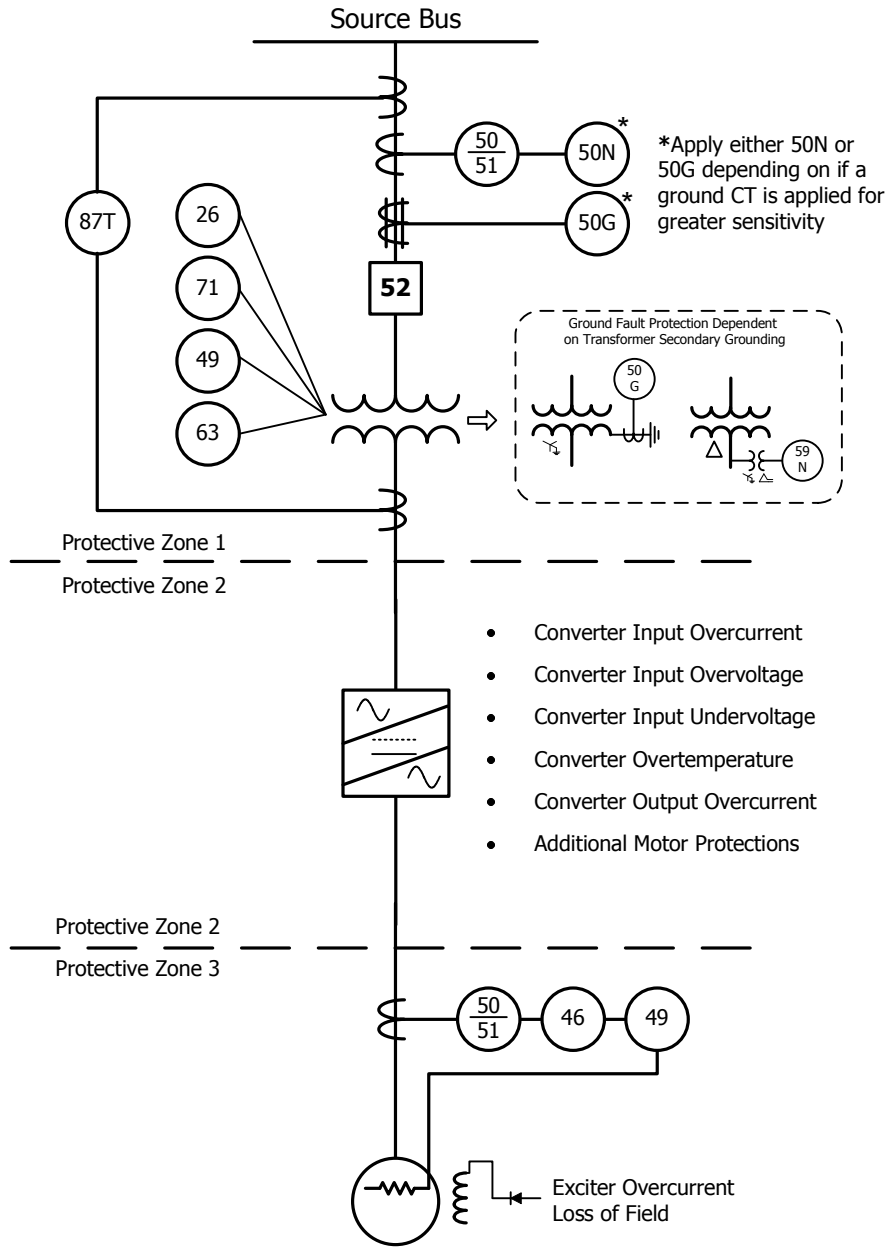

Figure 7: Synchronous Motor, with Transformer, No Motor Differential

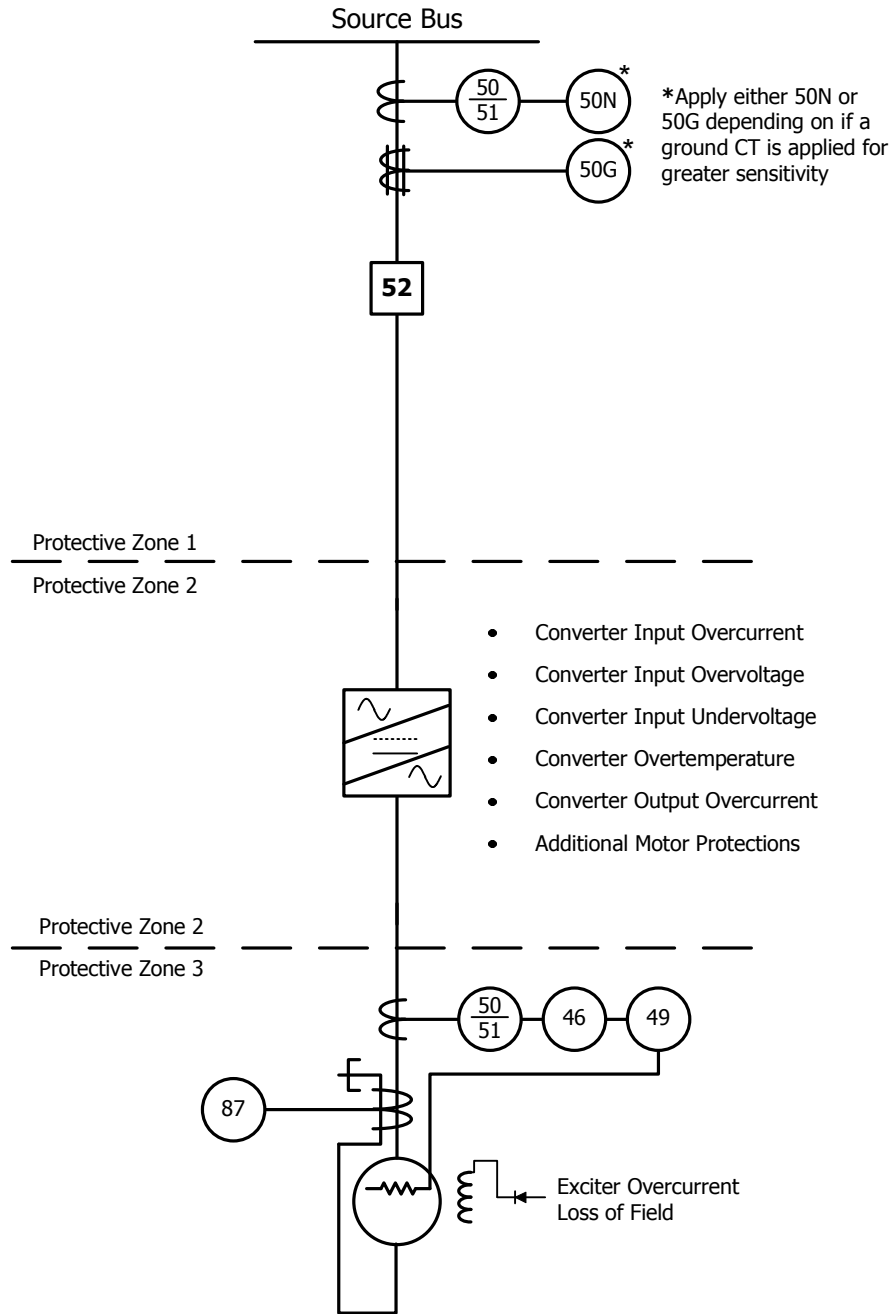

Figure 8: Synchronous Motor, no Transformer, with Motor Differential

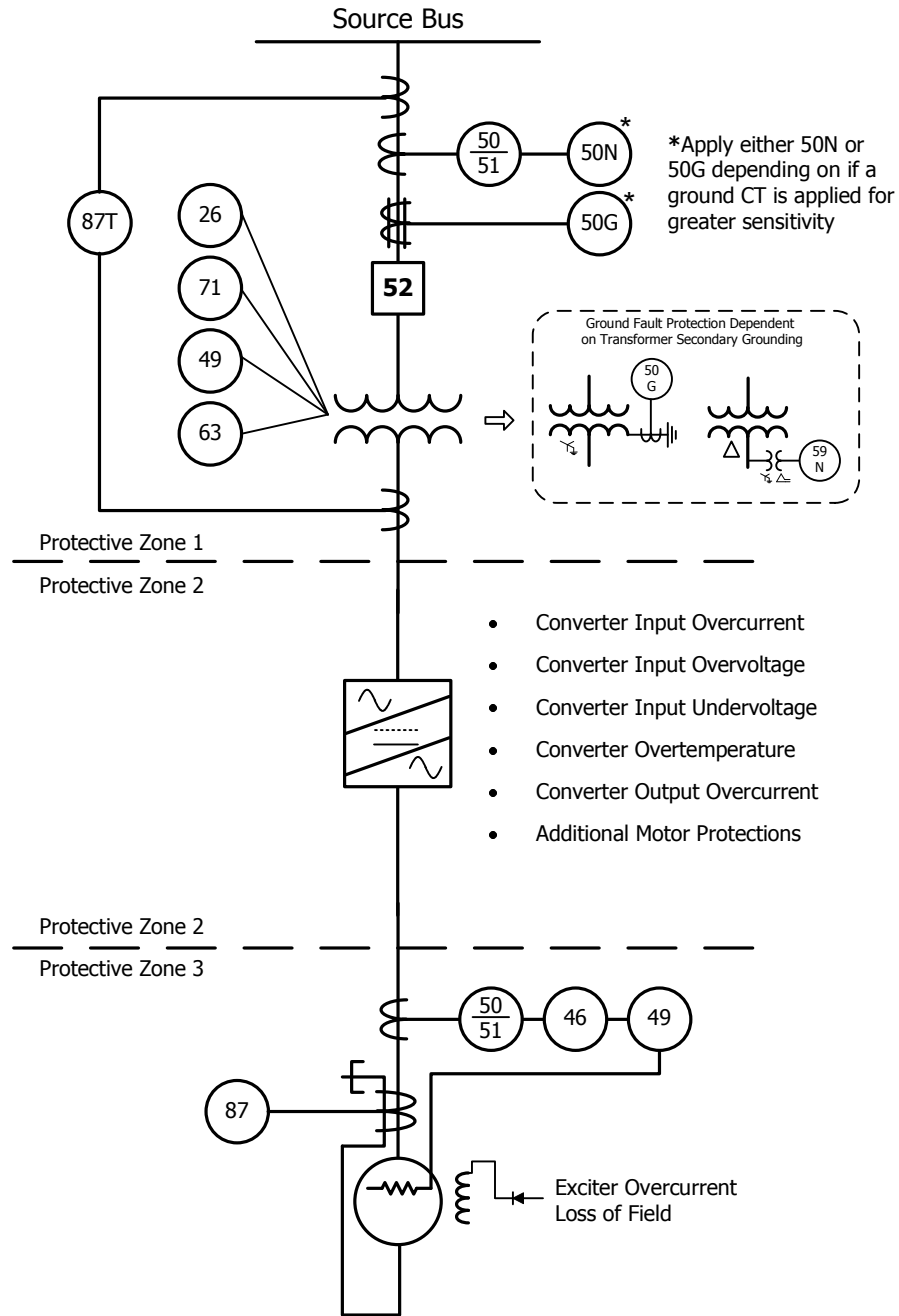

Figure 9 Synchronous Motor, with Transformer, with Motor Differential

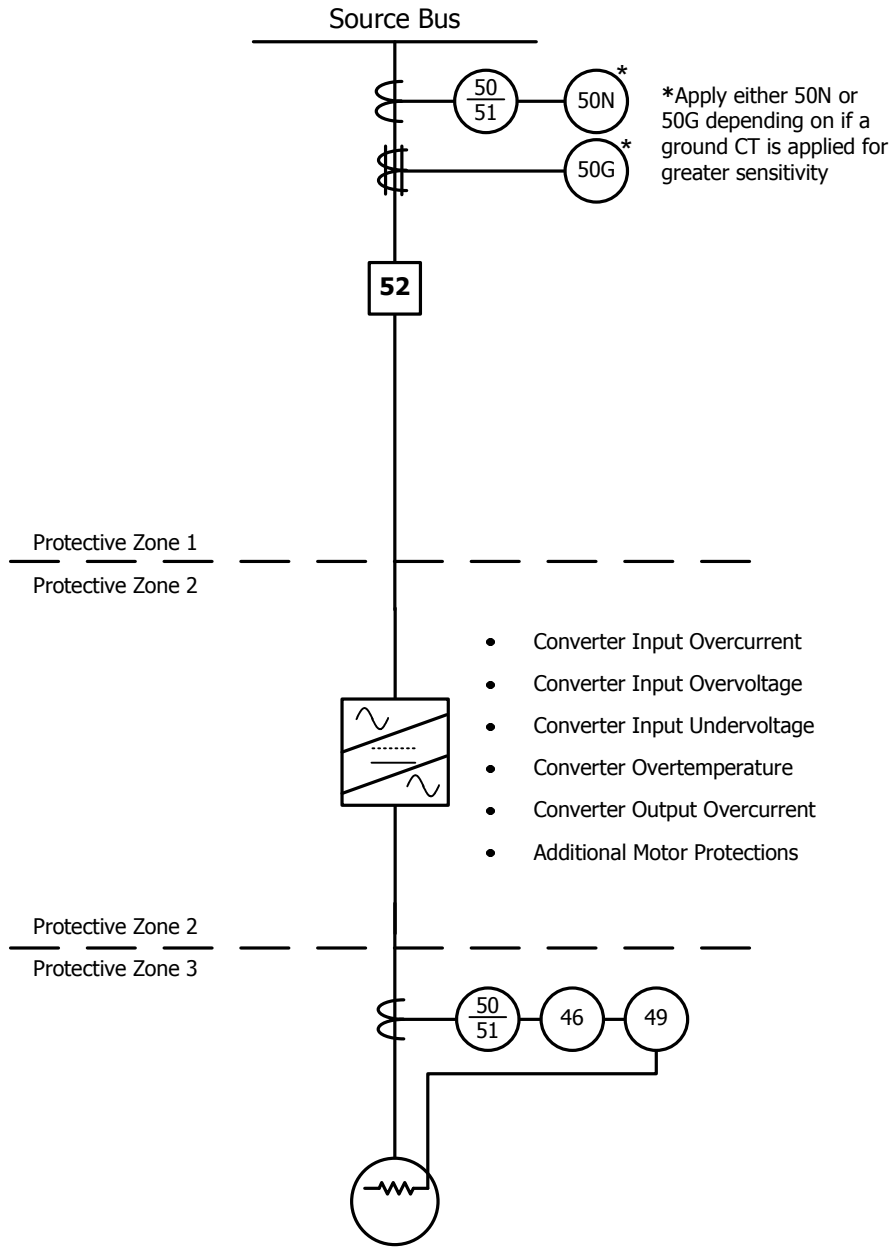

Figure 10: Induction Motor, No Transformer, No Motor Differential

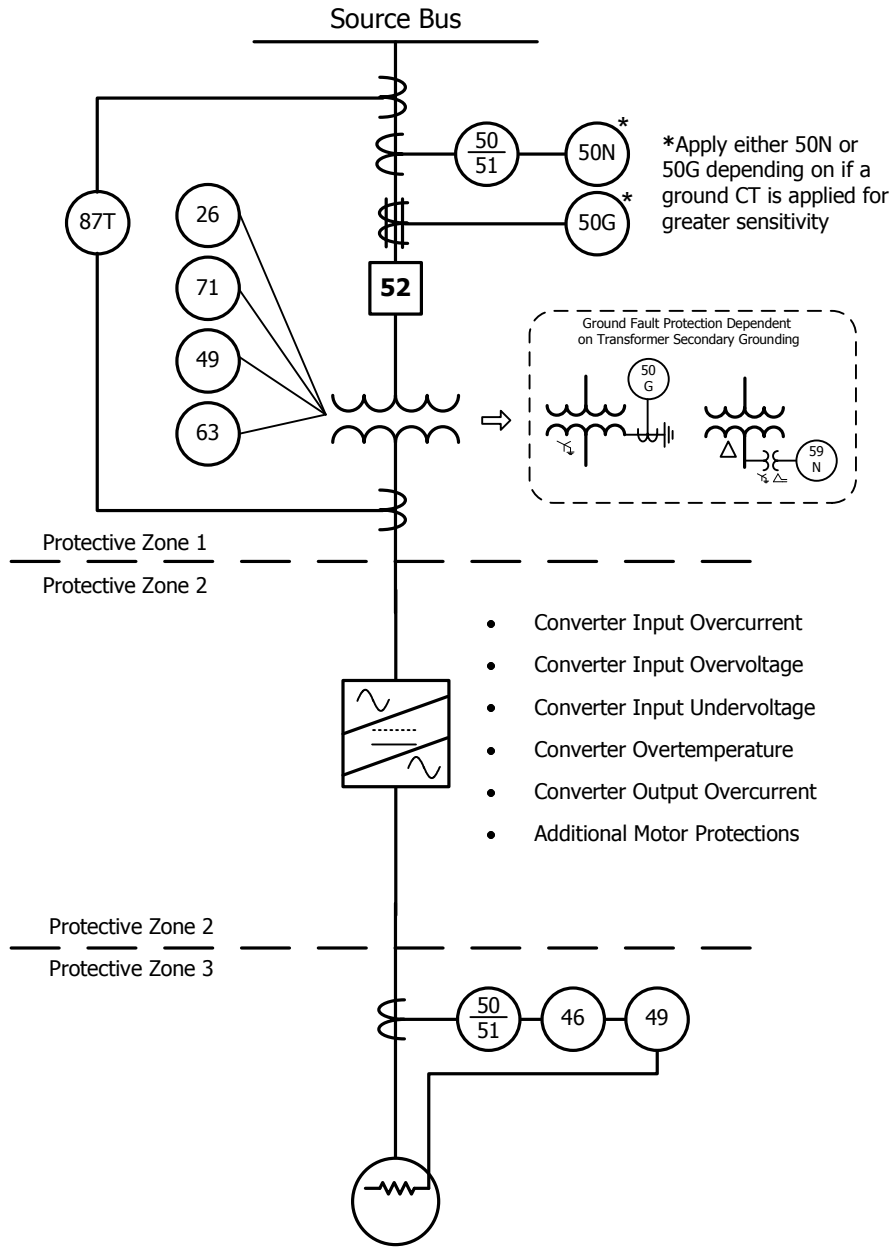

Figure 11: Induction Motor, with Transformer, No Motor Differential

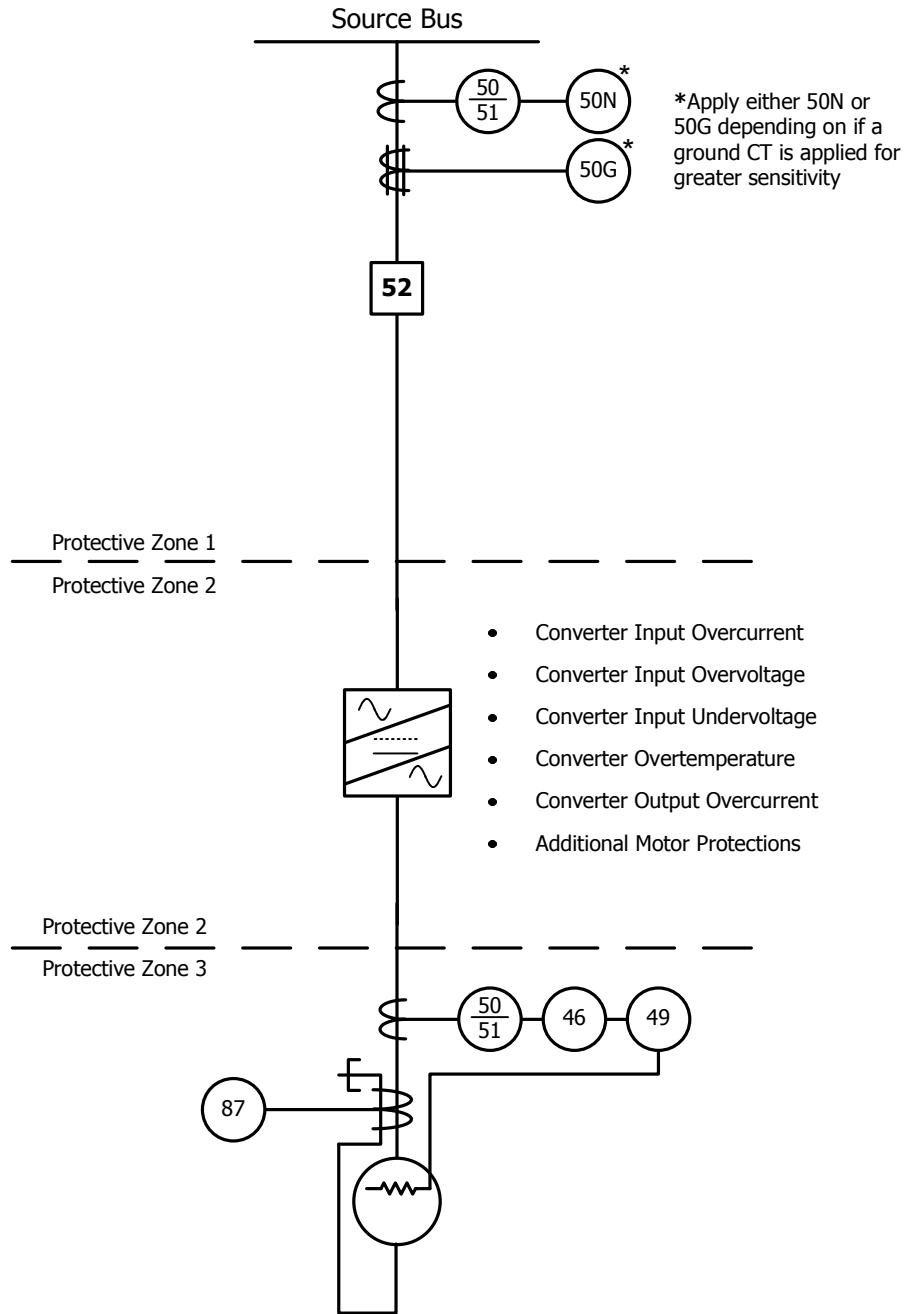

Figure 12: Induction Motor, no Transformer, with Motor Differential

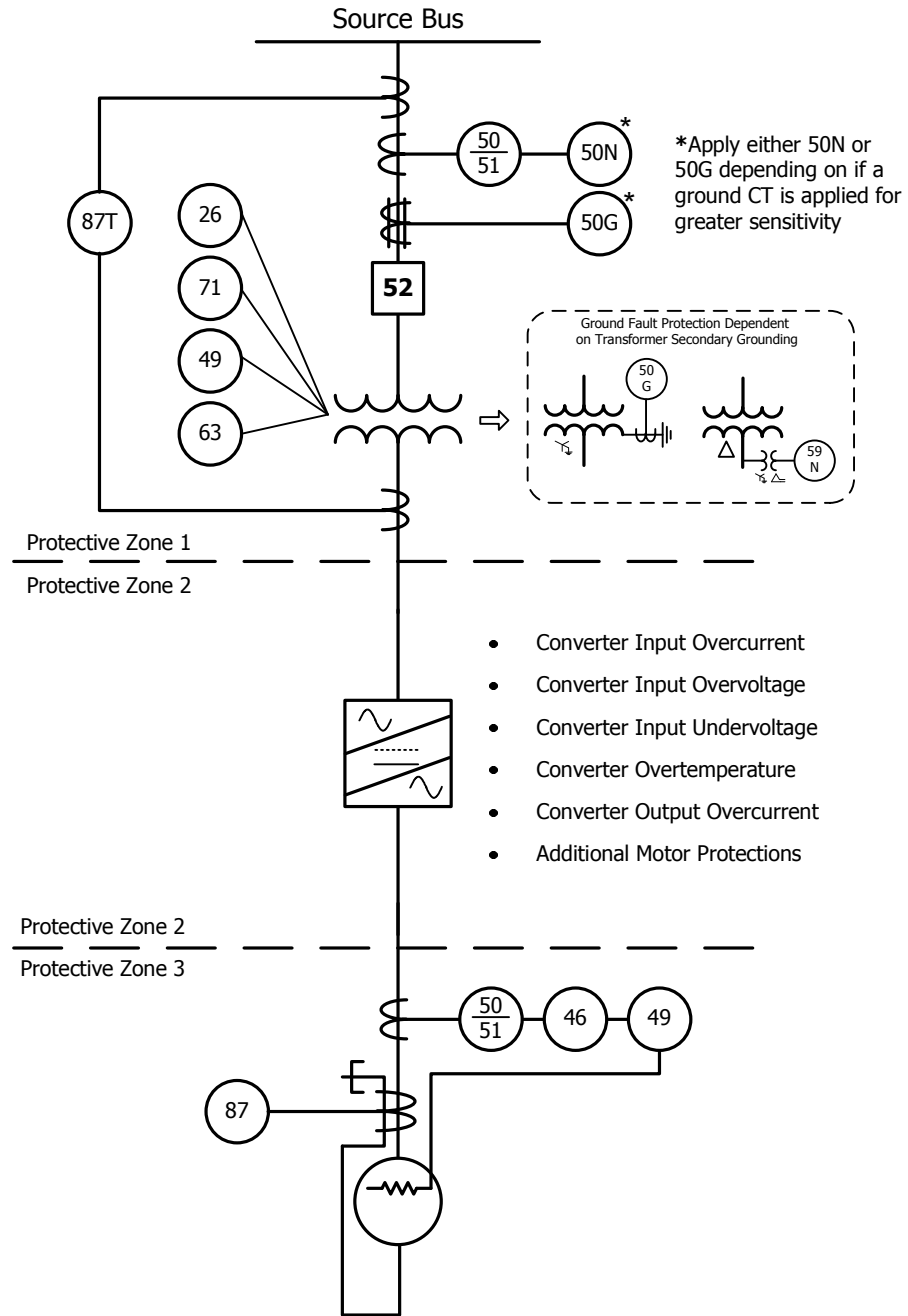

Figure 13: Induction Motor, with Transformer, with Motor Differential

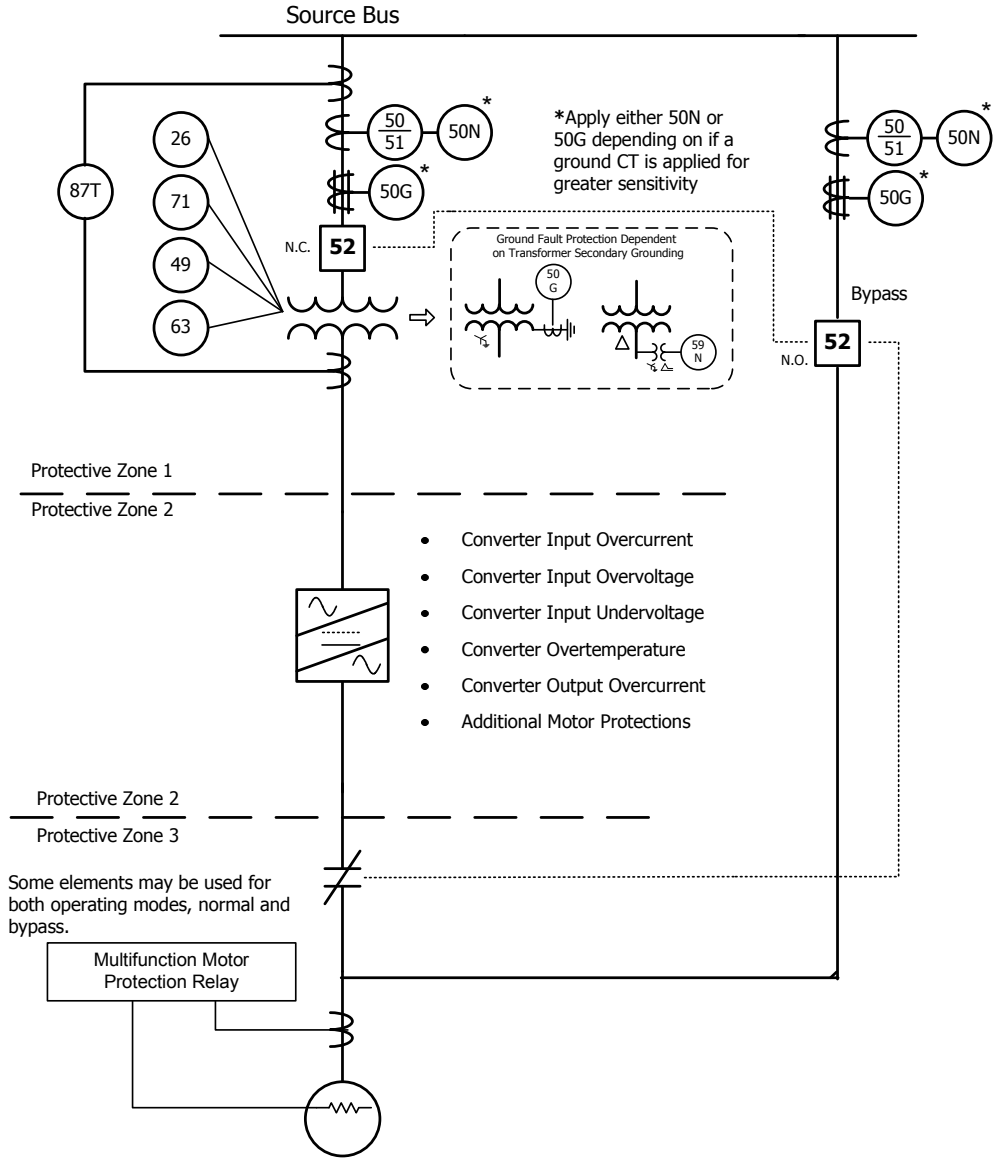

Figure 14: Induction Motor, with Transformer, No Motor Differential Bypass Contactor, 2 Contacts

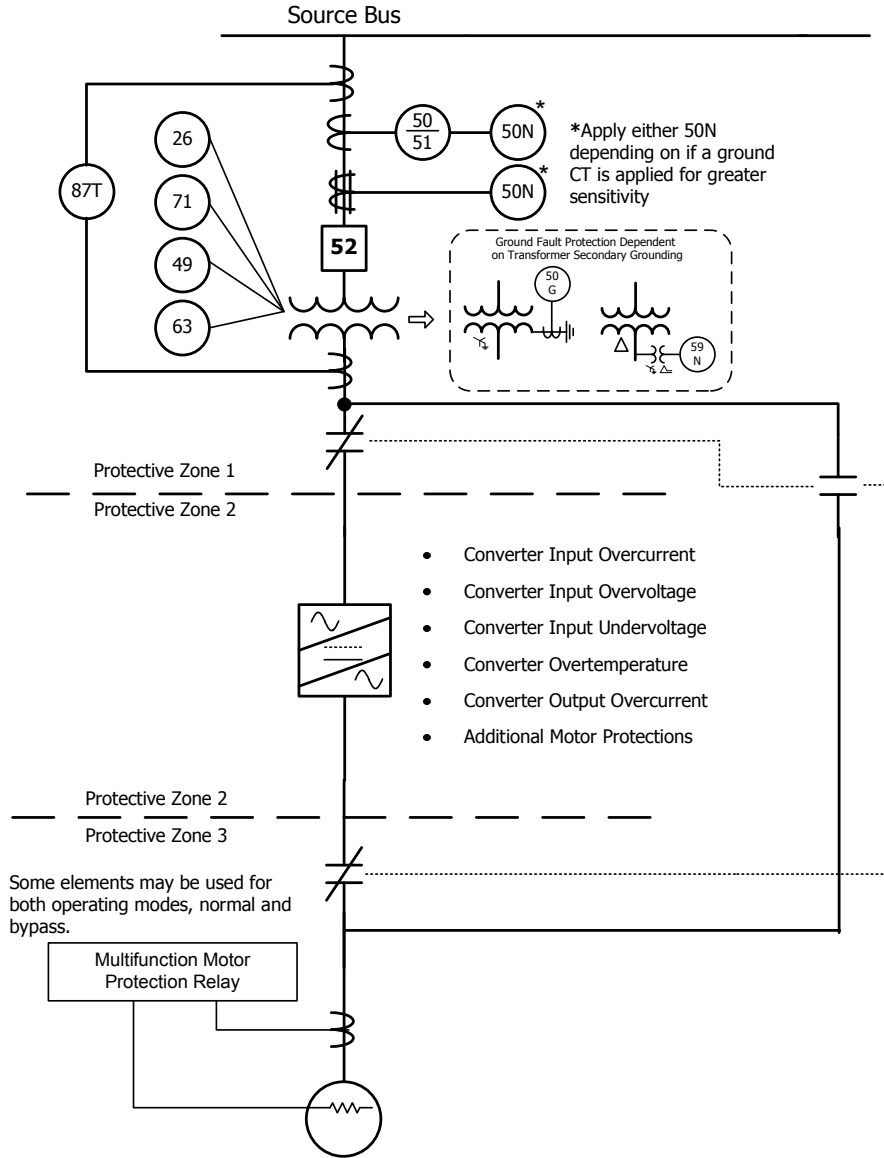

Figure 15: Induction Motor, with Transformer, No Motor Differential Bypass Contactor, 3 Contacts

## **X. Bibliography**

The following publications may provide information of interest to readers wishing to pursue the subject in further details.

[B1] IEEE Std. C37.96-2000, IEEE Guide for AC Motor Protection

[B2] IEEE Std. 958-2003, IEEE Guide for the Application of AC Adjustable-Speed Drives on 2400-13800 V Auxiliary Systems in Electric Power Generating Stations

[B3] NEMA Standards Publication ICS 7-2000, Industrial Control and Systems: Adjustable-Speed Drives

[B4] NEMA Standards Publication ICS 7.1-2000, Safety Standards for Construction and Guide for Selection, Installation, and Operation of Adjustable-Speed Drive Systems

[B5] NEMA Standards Publication ICS 61800-1-2002, Adjustable Speed Electrical Power Drive Systems, Part 1: General Requirements – Rating Specifications for Low Voltage Adjustable Speed DC Power Drive Systems

[B6] NEMA Standards Publication ICS 61800-2-2005, Adjustable Speed Electrical Power Drive Systems Part 2: General Requirements – Ratings Specifications for Low Voltage Adjustable Frequency AC. Power Drive Systems

[B7] NEMA Standards Publication ICS 61800-4-2004, Adjustable Speed Electrical Power Drive Systems Part 4: General Requirements – Ratings Specifications for a.c. Power Drive Systems above 1000 V ac. and Not Exceeding 35 kV

[B8] NEMA Standards Publication, Application Guide for AC Adjustable Speed Drive Systems

[B9] NEMA Standards Publication MG 1-2003, Motors and Generators

[B10] Von Jouanne, A., Enjeti, P., Gray, W., Application Issues for PWM adjustable speed AC motor drives, IEEE Industrial Applications Magazine, Vol. 2, Issue 5, pp 10-18, Sep/Oct 1996

[B11] ANSI/IEEE C57.110. “Recommended Practice for Establishing Transformer Capability When Supplying Non-sinusoidal Load Currents”.

[B12] NEC430-2 A Manufacturer Reference for Determining Drive Input Current Rating.

[B13] C37.100 [IEEE-100] “The Authoritative Dictionary of IEEE Standards Terms”

## Annex A - Nuclear Recirculation Pump Motor Application Summary

### A. Case Study – Nuclear Recirculation Pump Motor Application Summary

This is a large pump - motor retrofit project at a nuclear facility.

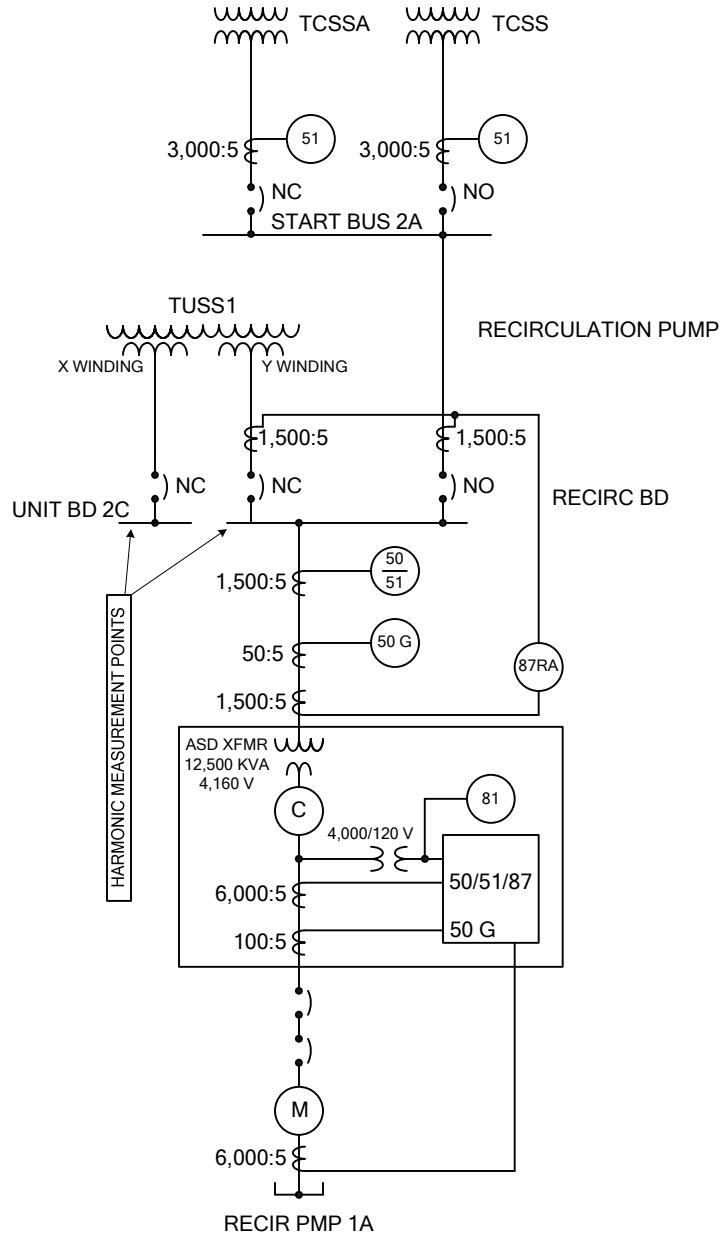

Figure A1: SINGLE LINE DIAGRAM

#### A.1.0 Introduction

The ASD data are from an electric utility company installation of a reactor recirculating pump motor in a nuclear power plant. The main 4.16kV power supply feeds the primary of an isolation transformer with 15 secondaries, with each secondary feeding a 690V

power cell. The required motor medium voltage level (4kV) is obtained by adding together the outputs of five low-voltage power cells (690V). The low-voltage static power converter cells receive 690Vac 50/60 Hz and deliver that power to any single phase load up to 690Vac and at any frequency up to 330Hz. To obtain 4800V L-L, four cells are required, for redundancy, a total of 5 cells are applied, and therefore 15 secondaries from the isolation transformer.

## **A.2.0 Equipment data**

### **Motor Data:**

4 Pole, Rating: 8550HP, 3948V, Phase: 3, Frequency: 56.4Hz, Full Load Current: 1083 amperes: Locked Rotor Current @ 57.5Hz and 4025V: 5300 amperes Locked Rotor pf: 14%, Safe Stall Time: 15 Seconds, Volts/Cycle: 70V/Hz, Starting Frequency: 11.5Hz.

### **Transformer Data:**

Rating: 12.5 MVA, 3 Phase, 4160V primary wye with 15 delta secondary windings at 690V, Inrush current 19300A, Impedance 9.5%.

## **A.3.0 Relevant Protective Devices (conventional and ASD) See Figure A1 Recirculation Pump Board in single line diagram.**

### **Drive Feeder side protection**

A.3.1 Device 50/51 – Instantaneous and Time Over current Relay **CT Ratio: 1500/5A**  
This protection is on the source side of ASD and provides conventional overcurrent protection for the isolation transformer. Since there is no differential protection for the transformer, the overcurrent protection, function 50 is the only high speed protection for transformer high side faults. The settings are set for a conventional transformer protection level, the 51 element provides the overload/overcurrent protection based on transformer mechanical and thermal damage curves and function 50 is set to protect against high side faults (above asymmetrical through fault current/inrush current). Conventional differential protection for the transformer would be impractical because of the number of secondary windings (15) and so it was not provided.

### **A.3.2. Device 87RA/87RB - Differential Over current Relay CT Ratio: 1500/5A**

This protection provides differential protection for the feeder up to the transformer. This protection, has the benefit of providing high speed clearing of all feeder faults up to the transformer, high currents faults in this zone would also be cleared by the 50 relay in high speed time.

### **Drive Motor side external protection**

### **A.3.3 Device 50/51/87 MMR – Motor Management Relays CT Ratio: 6000/5A**

For phase over current and differential protections (used as 1200/1, since 1 amp secondary relay is being used), 100/5A for ground over current protection VT Ratio: 4800/120V.

This protection is on load side of ASD and provides motor protection. For security reasons three phase relays were provided, and these relays were arranged in 2 out of 3 logic, so that any one spurious relay activation would not cause a trip. High ratio CT (6000 instead of 1200 allowed the use of a 1 amp relay applied at the vendor's request to enhance relay performance for harmonic currents).

The 50/51 element were also used, the 51 element was set to provide standard motor overload protection. However the inverse over current protection time curves were selected very conservatively (i.e. not selected just below motor withstand curves, which is generally done conventionally so as to maximize availability during overload conditions). This was implemented because motor withstand curves at sub nominal frequency currents were not available (where the motor will be starting and operating for significant periods of time). The standard motor stator and rotor thermal limit curves are based on fundamental frequency currents, at lower frequency currents, primarily at which the motor starts, the withstand will be less (due to different ac/dc resistance ratio). The differential element (87) was set conventionally, as a typical motor differential function.

The important issue for this protection is to ensure the selected relay would operate over a wide range of frequencies (motor runs between 11.5 Hz and 57 Hz). The security benefits of the 2 out of 3 logic can be considered for large base loaded units.

#### **A.3.4 Device 50G - Instantaneous Ground Relay CT Ratio: 100/5A.**

The isolation transformer is delta connected; therefore there is no ground source. This protection was applied for the situation when the static start system was bypassed and the motor was run or started across the line. The setting would handle the same as a normal across the line motor.

#### **A.3.5 Device DFR 81 - Digital Frequency Relay VT Ratio: 4800/120V**

Applied for over frequency protection.

Though the ASD internal controls will not permit operation at a frequency above 57 Hz, this protection provides an added external protection, to ensure against motor over frequency that would be harmful for this particular process.

This supplementary protection therefore should be considered when there are severe consequences for over frequency operations.

#### **A.4.0 ASD protection (internal):**

Motor Torque Limits 1, 2 and 3: Range 0 to 300% as a function of Rated Motor Current (limit 1) set at 120%

Drive Instantaneous Over current: Range 50-200% of Drive Output Rating Set at 140%

The ASD has inherent current limiting characteristics. Upon starting, the ASD provides the magnetization flux at minimal current; the initial frequency is 11.5Hz. After initial energizing, the magnetization torque current is applied to accelerate the motor from standstill to minimum speed. The ASD output current is limited to the torque limit

setting (120%) regardless of the current demand from motor. The motor operates with constant 70 volts per Hertz from 11.5Hz to 57.5Hz. However during starting at rest from ambient temperature, the system is capable of starting with 70% rated V/Hz, which is 49 V/Hz (i.e.  $70 * 0.7 = 49\text{V/Hz}$ ). Therefore the starting voltage for this motor would be from  $49 * 11.5 = 564$  volts to  $70 * 11.5 = 805$  volts (564 to 805 volts). The inrush current for these values (i.e. motor demand) of voltage would be 3163 amps to 4331 amps. However this is limited to the “torque limit” current setting (120% setting). Therefore the resulting acceleration to minimum speed will be slower than from the actual source.

The rated frequency is 56Hz ( $70 * 56 = 3920$  rated volts, and rated current is 930 amps).

The other internal ASD protective functions are single phasing, feeder over voltage, feeder under voltage control (reduce power to ASD to maintain correct torque), converter transformer thermal, motor over voltage, motor over speed and motor ground fault.

### **Annex B - Manufacturer A’s ASD Protection Example**

This is an example of one manufacturer’s internal ASD protection.

#### **Manufacturer A’s ASD and Relay Protection**

- I. When protecting an ASD without a bypass contactor, overcurrent protection is set per drive input current. NEC Article 430-2 describes the sizing of feeder and disconnects using the drive input current rating. Most drives provide phase loss, undervoltage/overvoltage input protection. Other relay protective functions such as over/under frequency, over/under voltage, negative sequence current, negative sequence overvoltage, and external RTD temperature measurement may be used if desired. However, these settings, if used, should be set as if the motor was controlled by a contactor.
  - A. The ASD will provide significant motor protection with:
    1. Motor thermal protection ( $I^2t$ )
    2. Overload fault management
    3. Drive overheating
    4. Thermal alarm stop
    5. External faults (monitored by inputs to drive)
    6. Short circuit between phases
    7. Ground faults
  - B. Here are the protection schemes employed today with Manufacturer A’s Adjustable Speed Drives.
    1. Short circuit / overcurrent protection - line side:
      - a. Circuit breaker - UL489 or UL98 rated; instantaneous trip or inverse time or
      - b. Fuse - Class CC, J, R, T (fast acting power semiconductor fuses typically used)
    2. Drive protective features:

- a. PTC management (probe inputs)
  - b. Fault reset input
  - c. Programmable automatic restart with time delay adjustment
  - d. Catch on the fly (synchronous restart)
  - e. Motor thermal protection ( $I^2t$ ) – provides for threshold alarms and overload fault management which has output modes to select/ignore, freewheel stop, maintain speed, preset speed, ramp stop, DC injection stop
  - f. Output phase loss has output modes to select; with or without time detection
  - g. Input phase loss has output modes to select; ignore or freewheel stop
  - h. Drive overheat (overtemperature) has output modes to select: ignore, freewheel stop, maintain speed, preset speed, ramp stop, DC injection stop
  - i. Drive thermal state
  - j. Thermal alarm stop
  - k. External fault has output modes to select: ignore, freewheel stop, maintain speed, preset speed, ramp stop, DC injection stop and assignment of logic
  - l. Undervoltage management:
    - 1) Fault logic
    - 2) AC Mains voltage – undervoltage level, time-out prevention, restart time, max start time, DC bus maintain time
  - m. IGBT (inverter section) test
  - n. Analog signal / 4-20mA follower loss
  - o. Fault inhibition
  - p. Forced run
  - q. Communication / Network protocol management
  - r. Torque or Current limit detection has output modes to select: threshold, stop and time-out adjustments
  - s. Dynamic braking resistor configuration (i.e. protection, resistor power, resistor value)
  - t. Automatic tuning fault
  - u. Option card pairing; detect when an option card or software programming has been modified
  - v. Process underload fault
  - w. Process overload fault
3. External components for drive coordination and systems:
- a. Typically supplied with full voltage or reduced voltage starter bypass schemes as part of a system
    - 1) Three phase power monitor - phase loss, phase reversal, voltage imbalance

- 2) Thermal overload relays - bimetallic or melting alloy
- 3) Motor protection relays 3 manufacturers

C. Also, the motor configuration settings can be addressed for power, voltage, FLA, frequency, rpm, auto-tuning, etc. A programming manual addresses specific details of items mentioned above.

- II. When an ASD and bypass contactor is used it is a good practice to consider changing the relay settings depending upon which device is controlling the motor. When the ASD is operational, relay settings should be determined by the drive input current rating per NEC 430-2. When in bypass mode, the relay settings should be determined by the motor nameplate ratings as motor protection is provided totally by the relay. A relay with a minimum of two setting groups should be utilized for a ASD/Bypass Contactor system. The setting group active in the relay is controlled automatically by a digital input representing the configuration of the system. For example; setting group A is used for ASD mode and setting group B for Bypass mode.

### **Annex C - Manufacturer B's ASD Protection Example**

In general there are three areas of ASD protection for Manufacturer B.

1. The drive input. The input to the drive needs a disconnect and protection.
  - A. The front end of a drive is always a transformer, and as such, the input device is treated as a transformer feeder in most cases. To that end we have supplied:
    - i. Load Break switches, fused. Provides isolation, and CLE fuse protection.
    - ii. Latched contactors, fused with CLE fuses, a protection relay of some sort can be employed, typically just the 50/51, 50/51G. But in some cases voltage functions are required by the end user, or drive vendor.
    - iii. Unlatched motor starters with motor protection relay for overcurrent, or feeder protection relays have been requested more often than latched contactors.
  - B. The drive itself can have input protection and can operate as a stand-alone device. Many drive manufacturers required that the input voltage is removed very soon after the drive shuts down. If that is the case, a breaker or contactor is used to separate the input voltage when the drive shuts down as discussed above.
2. Drive protections and depends on manufacturer.
  - A. The drive has a series of protection devices that are the same as a motor protection relay, with one exception V/Hz. V/Hz is not typically a protection provided in a motor protection relay, but is required to properly protect a motor that is running at reduced frequency.

- B. There are elements of protection integral to the process of converting AC to DC and DC to AC that are built into the drive, most cases these are semiconductor fuses to protect against short circuit.
  - C. Temperature of the drive is another area that is of concern to drive protections, but not seen in Motor Protection Relays (MPRs)
3. Drive Output.
- A. Stand alone drives can protect a motor with their internal controller. If an MPR is to protect the motor, a CT and GFCT should be added at the drive output cables.
  - B. Many applications request one drive to power many motors, one at a time. In these applications an additional contactor, the drive output contactor is added at the output of the drive, to connect to the motor. There are two additional contactors, one to connect the drive to a specific motor from an ASD bus, and another (bypass) contactor to connect the motor to the 60Hz or normal bus. The CTs for the MPR need to be on the motor cables after the junction of these two separate contactors.

Summary:

1. The MV drive can be stand alone, cable in/cable out, and the motor protected by its internal controller. End users often request an additional MPR to protect the motor, especially when bypass contactors are employed.
2. The MV drive can be fed by a feeder device with integral protections. This provides input protection and isolation for maintenance.
3. The drive output can be sent thru a set of CTs and the MPR can trip an output contactor.
4. Drive "Bus" schemes get complicated, but generally have a feeder protection relay on the input to the drive, with CLE fuse for short circuit protection. The drive has integral protection for the motor and drive output/bypass protection relay that protects the individual motor in either bypass or drive mode.

**Annex D - Harmonic data from a large ASD Motor**

This is measured harmonic data from a large ASD Motor. (See Figure A1 for Measurement Points in System)

**03/13/2003**

**Data Taken From Quality Instrumentation  
For The 'Recirc' Board and Unit Board 2C**

		<b>2C Unit Board Data</b>		<b>Recirc Pump Board Data</b>	
		<b>Phase A</b>	<b>Phase C</b>	<b>Phase A</b>	<b>Phase C</b>
Initial Reading 03:00 hours	RMS Volts	4447	4435		
	RMS Current	306.84	293.29		
	THD Volts	.9	.9		
	THD Current	2.4	2.7		
<hr/>					
500 RPM	RMS Volts	4449	4438	4493	4484
	RMS Current	309.61	295.83	46.10	43.08
	THD Volts	.9	.9	1.0	1.0
	THD Current	2.0	2.4	25.7	24.0
<hr/>					
800 RPM	RMS Volts	4444	4436	4492	4486
	RMS Current	308.56	295.3	121.51	115.34
	THD Volts	.8	.8	1.1	1.0
	THD Current	1.8	2.2	10.7	10.8
<hr/>					
1360 RPM	RMS Volts	4438	4428	4428	4421
	RMS Current	308.53	295.66	543.97	535.89
	THD Volts	.8	.8	1.1	1.2
	THD Current	2.3	2.7	3.1	3.2
<hr/>					
<hr/>					