

***IEEE/PSRC Substation Protection  
Subcommittee WG K5***

***Ancillary Protective and Control  
Functions Common to Multiple Protective  
Relays***

***December - 2009***

# ***IEEE/PSRC Substation Subcommittee***

## ***WG K5 Members***

Simon R. Chano, Chair, Dean Miller, Vice-chair, Joao Afonso, Mark Allen,  
Florin Balasiu, Martin Best, Fernando Calero, Randy Crellin, Alla Deronja, Kevin Donahoe,  
Dominick Fontana, George Gresko, Roger Hedding, Larry Henriksen, Bogdan Kasztenny,  
Bruce Mackie, Walter McCannon, Jim O'Brien, Frank Plumptre, Mohindar Sachdev, Gilles Santerre,  
Greg Sessler, Charles Sufana, John Tengdin, Damien Tholomier, Michael Thompson,  
Demetrios Tziouvaras, Roger Whittaker

## Table of Contents

EXECUTIVE SUMMARY .....	1
SCOPE.....	4
1 INTRODUCTION .....	4
2 PROTECTION AND CONTROL BACKGROUND INFORMATION.....	4
2.1 Protection Concepts .....	5
2.2 Control Concepts.....	6
2.2.1 Operator Initiated.....	6
2.2.2 Automatic .....	6
2.3 Monitoring Concepts .....	7
2.3.1 Front Panel Displays .....	7
2.3.2 SCADA Interface .....	7
2.3.3 Functional Monitoring .....	7
3 BREAKER FAILURE.....	8
3.1 Introduction and Basic Concepts .....	8
3.2 Factors that Influence the Design .....	9
3.2.1 Bus Arrangements.....	9
3.2.2 Fault Detection Relays .....	10
3.2.3 Security Versus Dependability .....	10
3.2.4 Relaying Philosophy and Maintenance Practice .....	11
3.3 Examples .....	13
3.3.1 Straight (ladder) Bus, Single Breaker .....	13
3.3.2 Breaker and a Half Bus .....	19
3.3.3 Double Bus/transfer Bus, Single Breaker.....	22
4 AUTOMATIC RECLOSING .....	25
4.1 Introduction .....	25
4.2 Automatic Reclosing on Transmission Lines .....	26
4.2.1 Three Phase Trip and Reclose Systems.....	26
4.2.2 Single Phase Trip and Reclose Systems .....	27
4.2.3 Selective Phase Trip and Reclose Systems .....	27
4.3 Automatic Reclosing on Distribution Lines.....	27
4.4 Input Signals to the Reclosing Relay .....	27
4.5 Location of the Reclosing (79) Function .....	28
4.5.1 Traditional Reclosing Relay .....	28
4.5.2 Integrated Protection and Reclosing Single Device .....	28
4.6 Redundant Reclosing Relay .....	29
5 APPLICATION OF OTHER CONTROL FUNCTIONS .....	30

5.1	Local Verses Remote .....	30
5.2	Issues of Concern, Traditional Verses Integrated Manual and Automatic Functions .....	31
5.3	Manual Backup or No Redundancy .....	38
5.4	Failover Redundancy.....	39
5.5	Parallel Redundancy .....	39
5.6	Non-redundant Secure Scheme .....	39
5.7	Triple Modular Redundancy.....	40
5.8	Control Philosophies .....	40
5.9	How Protection Elements Might be Applied for Control Automation .....	41
5.10	25 Synch-check Functions .....	41
5.11	27/59 Functions.....	42
5.12	52a, 52b Status Switches .....	44
5.13	50/50TD Overcurrent.....	44
5.14	86, Lockout.....	45
6	EVENT AND FAULT RECORDING .....	48
7	TESTING AND MAINTENANCE .....	49
7.1	Testing Issues .....	50
7.1.1	Disabling Settings for Testing .....	50
7.1.2	Testing Setting Group Change .....	50
7.1.3	Testing Programmable Logic.....	50
7.1.4	Testing External Inputs.....	51
7.1.5	Testing Targets and Output Contacts .....	52
7.1.6	Using the Digital Relay as a Commissioning Aid .....	52
7.1.7	Checking Directional Relay Polarization .....	52
7.1.8	Firmware Revisions .....	52
7.2	Documentation .....	53
7.2.1	Introduction .....	53
7.2.2	Documentation Issues of Protection and Control Functions in an IED .....	53
7.2.3	Documentation Issues of Protection and Control Functions in different IEDs.....	56
7.2.4	List Box .....	58
8	REFERENCES .....	59
	ANNEX 1: Example of Breaker Failure/Reclosing Functions in One Relay .....	60
	ANNEX 2: Example for an Automatic Transfer Scheme.....	64
	ANNEX 3: Example of a Shunt Capacitor Protection Scheme .....	67
	ANNEX 4: Example of Transformer Trip and Isolation Logic.....	69
	ANNEX 5: Example of an Analysis of the Allocation of Breaker Failure Functions in Line Relays .....	71
	ANNEX 6: Example of Using Two Multifunction Line Relays on a Single Breaker.....	74

## List of Figures

Figure 3.0 - Possible Allocations of the Fault Detection (FD) and BF Functions Between Multiple Relays. ....	12
Figure 3.1 - Straight Bus, Single Breaker, BF Implemented in Each Relay .....	14
Figure 3.2 - Straight Bus, Single Breaker, BF Implemented in Only the Bus Relay .....	15
Figure 3.3 - Straight Bus, Single Breaker, BF Implemented in Only the System A Relay .....	15
Figure 3.3(a) - Straight Bus, Single Breaker, BF Implemented in a Switchover Scheme .....	16
Figure 3.4 - Straight Bus, Single Breaker, BF Not Available in the Bus Relay .....	17
Figure 3.4(a) - Straight Bus, Single Breaker, BF Cross-checked Between the Relays .....	17
Figure 3.4(b) - Internal Relay Logic for the Example of Figure 3.A.4(a) .....	18
Figure 3.4(c) - Internal Relay Logic for the Example of Figure 3.A.4(b) with Extra Security for Spurious External BFI Signals .....	19
Figure 3.5 - Breaker and a Half, External Breaker Failure Protection .....	20
Figure 3.6 - Breaker and a Half, BF Implemented in Each Relay .....	20
Figure 3.7 - Breaker and a Half, BF Implemented in System A Relay .....	21
Figure 3.8 - Breaker and a Half, BF Implemented in Bus Relay .....	22
Figure 3.9 - Double Bus/Transfer Bus, Single Breaker, BF Implemented in Bus Relay .....	23
Figure 3.10 - Double Bus/Transfer Bus, Single Breaker, BF Implemented in Each Relay .....	24
Figure 4.1 - Breaker Contact Position and Automatic Reclosing Operation.....	26
Figure 4.2 – Separate Reclosing Relay.....	28
Figure 4.3 - Single Device with Protection and Reclosing Functionality .....	29
Figure 4.4 - Redundant Device Reclosing with Manual Transfer.....	29
Figure 4.5 - Redundant Device Reclosing with Cross Initiation .....	30
Figure 4.6 - Redundant Device Reclosing Scheme.....	30
Figure 5.0 - Duplication of Integrated Control of a Single Breaker.....	33
Figure 5.1 - Duplication of Integrated Dual Breaker Control .....	36
Figure 5.2 - Options for Providing Redundant Breaker Control .....	37
Figure 5.3 - Control for Dual Breakers without Redundancy .....	38
Figure 5.4 - Jurisdiction of Lockout Function.....	46
Figure 5.5 - Integrated Protection .....	47
Figure 7.0 - Programmable Logic.....	51
Figure 7.1 - Example of a Custom Protection and Control Function in a Single Line Diagram .....	54
Figure 7.2, Documentation of Internal IED Logic.....	54
Figure 7.3 - Elementary DC Diagram of the Breaker Status, Trip and Close Circuits of a Single Phase Trip Scheme .....	55
Figure 7.4 - Example of an I/O Cross-Reference Table .....	56

Figure 7.5 - Documenting IED's Communication Links .....	57
Figure 7.6 - Documenting Serial or Ethernet Network Messages .....	57
Figure 7.7 – List Box Documenting Method .....	58

## EXECUTIVE SUMMARY

The IEEE Power System Relaying Committee (PSRC), Substation Protection Subcommittee, Working Group K5 on Ancillary Protective and Control Functions Common to Multiple Protective Relays have produced a document that addresses the considerations in applying the ancillary protection, control and monitoring functions that are common in multiple relays and the integration of these functions into the overall protection system. Today's modern protection schemes come with fully integrated protection, control and monitoring functions to accommodate the implementation of many different design requirements to achieve a reliable protection and control solution. This freedom of implementation can be an exhilarating challenge to the engineer's imagination. This document addresses subjects related to specific protection and control topics with application examples. Topics on breaker failure, automatic reclosing, synchronism check, voltage status monitoring, breaker controls, event and fault recording; testing and maintenance considerations are also covered in this document.

The applications of duplicate protective schemes in modern protection is of big interest to users as almost all numerical protective relays now give the user the ability to either modify the existing protection and control logic inside the relay or add specific logic tailored to the user's requirements. This advancement in the state of the art has enabled the user to implement a whole host of tripping, transfer, monitoring and control schemes as part of a custom made logic inside the main protective relay thus allowing the elimination of external relays, auxiliary relays, timers, and wiring. Whether they are installed in new substations or as retrofits in old substations, multifunction relays can be successfully applied to satisfy both the protection and control requirements of the power system equipment. The choice of implementing protection and control functions depends largely on the equipment to be protected, the power system operating requirements, and the owner's comfort level with multifunction relays.

There are virtually no limits on the variety of new protection schemes that can be designed to satisfy specific application requirements. A major challenge for the engineer is to balance the ability to provide redundancy of functions against the requirement to "keep the system simple".

Application examples of improved protection and control schemes have been documented in this report in the areas of breaker failure scheme logic, line reclosing scheme logic, sync check, or interlocking. In the area of monitoring, programmability gives the multifunction relay powerful monitoring and alarming capabilities. Breaker trip coil and loss of voltage monitoring are good examples of these capabilities. Monitoring the status of terminal components for the purposes of modifying protection schemes, such as for open terminal conditions or to provide stub bus protection when the line motor operated disconnect is open, are also excellent examples of the enhanced monitoring features of multifunction relays. Event data recorded in microprocessor based relays, both analogs and status, is an important tool for the post analysis of the event.

In breaker failure schemes, Relaying philosophy and maintenance practice impact significantly the selection of a BF scheme. Factors to consider are:

- Preferred degree of security and reliance on remote versus local backup.
- Degree of integration of the fault detection and BF functions on a single multifunction relay.
- Existing maintenance/testing practice, willingness and capacity to adjust.

- Preferences with respect to simplicity and cost targets.

In automatic reclosing schemes, present technology multifunction devices offer the 79 function at no extra cost. Whether automatic reclosing (AR) is implemented as a dedicated reclosing relay or as a programmable function within a multifunction protection relay, several external input signals may be required for successful implementation, depending on the design requirements of the reclosing scheme. Typical input signals required by reclosing relay schemes include but are not limited to reclose initiation, breaker status (open or closed), drive to lockout, pause, and voltage or synchronism check supervision.

In a case when redundancy of the AR function is required, both primary and backup tripping relays are equipped with an AR function. Being a control function with a relatively complex sequence of steps, AR is typically not allowed to have multiple operational instances. Therefore, one of the ARs is selected as the normal (master) device, and the other is enabled only if the master device is not operational. This is typically done via hard-wiring of the fail safe relay of the master device to the secondary device. Such a scheme can be referred to as “hot standby,” meaning that there is a second copy of the function, purposely inhibited due to coordination concerns, but available instantly if the primary function be not available.

This report is supported by many application examples in the annex section and gives thorough discussions on intelligent electronic device (IED) control function schemes used in modern protection numerical relays where point to point wiring associated with the cascading device outputs of a traditional scheme might be reduced or eliminated. Control system architecture, will depend upon the required redundancy, and the choice of which hardware platforms are to contain the line, bank, bus, or breaker failure protection. The degree of integration practiced by the utility may range from fully integrated, where relays provide not only remote and local breaker control but also status, alarm, and metering information, to partial integration, where relays provide only for local automation such as in automatic transfer or isolation schemes.

Schemes that most effectively measure the conditions from only a single power station can be migrated from remote manual to local automated control. The resulting simplified schemes have fewer components that can fail (no telecommunication channel). The potential for human error is also reduced. Remote arming or manual backup to this automated control may be included. One example is the automation of switching of a shunt capacitor bank to control local voltage. A relay that is applied to protect the capacitor bank can also measure the bus voltage, make a control determination, and initiate switching. This fully automatic control scheme can be removed from service at any time by a remote supervisory control and data acquisition (SCADA) operator.

If redundancy has already been provided to satisfy protection requirements, the dependability, security, availability and simplicity of control schemes may be improved with functions that are inherent in the numerical relays. New techniques may require changes to process and thinking. However, it is important that the addition of control functions in multifunction relays does not degrade protection performance. Inappropriate or failed control can cause equipment damage or unsafe conditions.

In this report, maintenance is also considered. Physical switches for isolation (make-before-break), injection testing, and cutting the relay out of service may be provided at the option of the utility. Connectorized cables might be applied to the control circuit outputs for possible disconnection. Virtual switches that reside as logic elements within the IED can prevent unwanted transmission of alarms during maintenance. The test switch variable may be “set” by switching on the control voltage to a device input by the same physical test switch that is

operated to remove the device from service. This test switch variable can be combined with the control logic result for each alarm or output as inputs to the AND gate function. A virtual test switch may be used to prevent unwanted alarm signals from being sent to the control center during device testing. It can be used to test changes to relay or control logic by blocking the device output. This is especially useful when the outputs are network messages. The need to trip check power circuit breakers is avoided if control wiring is not disturbed.

Event and fault recording are helpful tools when analyzing faults on the electric system. Most microprocessor relays provide these tools in some form. This document describes situations where multiple relays are used for protection, control and monitoring to retrieve event or fault data from multiple sources. The ability to compare records from several sources, however, may prove useful. Different relays handle several issues such as frequency response, record length, triggering, record storage, setting files, software, off-nominal frequency, and other issues in different methods. One may be able to gather more information by gathering information from multiple relays. To obtain the full benefit of these comparisons it helps to have the relays time synchronized. The usage of an IRIG-B signal from a global positioning system (GPS) time source can provide the time synchronization.

Another useful method to ensure more data is collected during events is cross-triggering or cross-initiation. Cross-triggering or cross-initiation is the function where one relay senses an event and sends a signal to other relays so they can begin their event and fault capture as well. The benefit is that all relays provide data so that analysis can be more complete. The cross-triggering or cross-initiation can be accomplished by hard wiring an output of one relay to the input of other relays or it can be accomplished by peer to peer communications.

Applications where this can be particularly helpful are where two relays are providing protection for the same zone, such as primary and backup or Set A and Set B relays on a line terminal, transformer, or bus. Having data from both relays can often be of assistance in trouble shooting should one of the relays operate falsely or fail to operate. Comparison of the two sets of event reports also provides an opportunity to verify that current and voltage signals are interpreted consistently in both relays, and allow identification of current transformer (CT) or voltage transformer (VT) connection errors or setting errors even if both relays operated for a fault.

Testing and maintenance are also covered and although the overall maintenance frequency is reduced for microprocessor relays due to the self-monitoring, the use of many functions in one microprocessor relay can create issues with maintenance and testing. The maintenance of one microprocessor relay could remove needed protection for a circuit and therefore, the circuit may have to be cleared. Clear documentation is therefore needed to ensure proper protection is maintained during maintenance. The document discusses all these important issues in the documentation section.

To summarize, multifunction digital relays that perform protective, control and monitoring functions offer unique challenges to the user. Multifunction relays have protective functions that interact with each other, making testing more complicated. They can also be programmed to do control logic, which is usually verified along with the protection logic during commissioning. In addition, digital relays can have multiple setting groups that may be switched to address varying system conditions. This flexibility increases the commissioning complexity. Due to the additional complexity it is important for the user to fully understand the schemes and how they interact. The simple testing of one integrated protection element in an IED could trigger an undesirable operation of a breaker failure scheme. The documentation of the schemes is very important and those who test the relays have to completely understand the behavior of a system.

## SCOPE

Develop a document that addresses the considerations in applying the ancillary protection and control functions that are common in multiple relays and the integration of these functions into the overall protection system. This document addresses subjects related to specific topics such as: breaker failure, automatic reclosing, synchronism check, voltage status monitoring, breaker controls, and event and fault recording. The applications of duplicate protective schemes are discussed with consideration for security, dependability, testing, and maintenance.

## 1 INTRODUCTION

A great number of microprocessor based protective relays now give the user the ability to either modify the existing protection and control logic inside the relay or add specific logic tailored to the user's requirements. This advancement in the state of the art has enabled the user to implement many tripping, transfer, monitoring and control schemes as specialized logic inside the main protective relay. The overall reliability of the protection and control system is thus improved by eliminating the external relays, timers, and wiring that used to be required to implement the additional logic. Whether they are installed in new substations or as retrofits in old substations, multifunction relays can be successfully applied to satisfy both the protection and control requirements of the power system equipment. The choice of protection and control functions implemented depends largely on the equipment to be protected, the power system operating requirements, and the owner's comfort level with multifunction relays. A major challenge for the engineer is to balance the ability to provide redundancy of a function against the requirement to "keep the system simple". Given all the different design requirements to satisfy, designing and implementing a final protection and control solution using multifunction relays can be an exhilarating and very satisfying challenge to the engineer's imagination.

The report starts out with basic protection, controls, and monitoring concepts followed by discussions of specific factors involved in the design of breaker failure protection, automate reclosing, and control and monitoring functions using multifunction relays. In the annex to the report are examples of applications of multifunction relays used to implement ancillary protection and control functions. It is important to note that although this report has had extensive review and attempts have been made to present a broad perspective on the subject, the report is not an IEEE standard, guide or recommended practice. As such the report is primarily the opinion of the authors and has not gone through the scrutiny that a standard, guide, or recommended practice must undergo before distribution

## 2 PROTECTION AND CONTROL BACKGROUND INFORMATION

Traditionally, individual electro-mechanical and electronic devices were provided to perform specific functions according to agreed and accepted user practice for designing protection, control, and monitoring functions. Many modern numerical devices can provide some or all of these functions embedded in the same device. The challenge for the protection engineer is to select the desired protection and logic functions from the many that are available in multifunction relays and to integrate the relays and their functions into a cohesive protection and control scheme.<sup>1</sup>

---

<sup>1</sup> In IEEE Std C37.2, multifunction relays are designated as Device 11 – multifunction device "A device that performs three or more comparatively important functions that could only be designated by combining several device function numbers."

## 2.1 Protection Concepts

Protection philosophies vary depending on different utility practices and engineers. The digital logic functions available in multifunction relays provide the protection engineer with the means and flexibility to customize the protection and control logic to satisfy a wide range of system requirements and constraints. Specific details such as what protection functions to include, how much backup protection to provide, and what protection scheme logic to implement depend on the unique application and operating requirements of the user. When designing protection schemes using two or more multifunction relays, the protection engineer may be required to select which relay in the scheme will be used to provide specific protection functions and logic. The selection process itself may be governed by additional scheme design requirements such as sensitivity, speed, security, or reliability. The following system objectives and guidelines have been found to be helpful in the process of applying multifunction relays to implement protection and control schemes.

1. **The protection functions or logic available in the relay are to be selected and applied to meet the specific requirements and objectives of the protection scheme.** The choice of functions and the complexity of the logic to be implemented will require some careful thought to ensure that their individual characteristics or operation will satisfy the overall design requirements of the protection scheme. Not every protection or logic function should be used simply because it is available in the relay.
2. **The protection scheme functionality and logic are to be designed in accordance with established utility or industry practices.** A chief objective of the design is to ensure compliance with accepted requirements for sensitivity, speed, security, reliability, and simplicity. An equally important objective is that the design complements established safe work practices for field operations and testing personnel.
3. **The protection scheme is to be kept as simple as possible but no simpler than necessary.** Both “over-engineered” protection schemes which attempt to apply every relay function available and “under-engineered” protection schemes which attempt to provide comprehensive protection using a minimal number of relay functions or equipment are to be avoided. For example, a complete subtransmission line protection scheme using a single multifunction relay provides a simple scheme using minimal equipment, but the additional complexity of adding a second multifunction relay may be justifiable to increase the overall dependability of the scheme.
4. **The system can still provide protection if any single device fails.** This design objective is a corollary of 3 and may be used as an aid to avoid either an “over-engineered” or an “under-engineered” protection scheme. For critical applications, such as EHV transmission lines, the scheme design may need to retain high speed protection for a single component failure and slower speed protection for a double failure. Some contingency analysis may be required to predict how the protection scheme will perform with the loss of critical pieces of equipment. The contingency analysis usually includes all the equipment associated with the scheme (i.e. battery system, current transformers, voltage transformers, lockout relays, wiring, wiring devices, circuit breakers, trip coils, and so on) as well as the protective relays.
5. **The protection scheme design is to include adequate provisions for testing and maintenance.** While most multifunction relays do not require the same

routine test intervals as electromechanical relays, multifunction relays may occasionally require replacement in the event of component or system failure or special testing, such as testing after a power system disturbance. Designs that are easy to test and maintain help to ensure that the system can be tested and commissioned efficiently and safely.

6. **To the extent practical, protection logic is to reside in the multifunction relays or protection logic processors comprising the protection scheme rather than being hard-wired.** Protection logic implemented as software or firmware inside the relay simplifies the panel layout, minimizes auxiliary relays and wiring, and retains logic flexibility for future system changes.
7. **The protection engineer will coordinate closely with other departments, such as supervisory control and data acquisition (SCADA), Communications, and Operations to ensure that the ancillary control and monitoring functions of the protection scheme are compatible with established requirements and procedures.**

There are virtually no limits on the variety of new protection schemes that can be designed or on the ability to improve existing protection schemes to satisfy specific application requirements. Application examples of improved protection schemes have been documented in the literature in the areas of distribution bus protection, the application of multiple relay settings groups, breaker trip coil monitoring, redundancy of protection and control functionality, breaker failure relay scheme logic, and line differential protection. Some additional specific application examples include the use of restricted earth fault logic to protect the wye windings of large transformers, the application of definite time elements (50TD) instead of traditional 51 (inverse time) elements, and blocking (fast bus trip) schemes for the protection of distribution substation buses.

## 2.2 Control Concepts

### 2.2.1 Operator Initiated

In addition to protecting the power system equipment, a multifunctional relay can enable the local operator to:

- trip and close breakers
- enable or disable remote control
- select or configure automatic reclosing
- reset lockout functions

Each of these tasks might be done directly from the front panel of the relay. The relay can act as an interposing device to enable control by operators from a remote control center. It can communicate with and provide status information to the local station computer, and it can provide this same information over a communication channel to the control center.

### 2.2.2 Automatic

The relay can measure switchyard conditions used to supervise both manual and automatic control. Internal relay logic might be used to implement functions for close permissives, synch-check, or interlocking. The relay can initiate switching to automatically restore or isolate equipment. External wiring can be reduced and traditional equipment such as SCADA transducers, remote terminal units

(RTUs), or programmable logic controllers (PLCs), often designed by separate design departments, can be replaced or eliminated.

Issues such as dependability, security, flexibility, simplicity, and upgrade ability will be discussed as related to the design of the control system architecture. This will impact the ability to control during equipment malfunction or maintenance. Consideration is given to how the control scheme might accommodate future power system equipment replacements or additions.

## **2.3 Monitoring Concepts**

Monitoring functions provided with modern digital multifunction relays have greatly simplified and streamlined the look of today's relay panels by eliminating the need for discrete devices. Not only can the status of power system components be displayed, but voltage, current and power metering quantities can also be shown.

### **2.3.1 Front Panel Displays**

Relay front panels are typically divided into separate sections. Hardwired and programmable targets are typically provided on one section. Targets will describe the type of fault, identify faulted phases and indicate if the trip was time delayed or instantaneous. Hardwired and programmable status LEDs would be displayed in another section of the front panel. These LEDs could also be used for alarming purposes. Line relays could be programmed to show the positions of terminal breakers and motor operated disconnect switches as well as remote terminal devices if communications links are provided. Many relays incorporate the use of a LCD screen which can be made to display many different types of information. Relay settings can be displayed and modified using these screens. Metering quantity displays and the health of terminal components such as breakers can also be programmed in a scrolling format within these LCD windows. Scrolling is usually controlled by integrally mounted directional pushbuttons.

### **2.3.2 SCADA Interface**

For larger substations, relay front panel display information is made available via various communications links to the SCADA RTU for remote monitoring and alarming. For smaller substations, information gathered by the relays could be made available remotely from the relay itself without the use of an RTU. A secure network environment with redundant communications may facilitate the elimination of the SCADA RTU altogether.

### **2.3.3 Functional Monitoring**

Programmability gives the multifunction relay powerful monitoring and alarming capabilities. Breaker trip coil and loss of voltage monitoring are good examples of these capabilities. Monitoring the status of terminal components for the purposes of modifying protection schemes, such as for open terminal conditions or to provide stub bus protection when the line motor operated disconnect is open, are also excellent examples of the enhanced monitoring features of multifunction relays.

The recorded data of an event in the microprocessor based relays, of both analogs and status, is an important tool for the post analysis of the event.

If a single station battery is used in a substation, DC system monitoring should be provided and remote backup will be required. The capability to monitor the

station battery and to send an alarm to other relays or to the SCADA system is available in many types of multifunction relays. At remote substations additional protection schemes should be provided as remote back-up protection if a fault occurs at the local substation after the station battery fails or is taken out of service. An alternative would be to install a second station battery and duplicate protection circuits. Care in design and construction must be taken to maintain the independence of the two sets of protection systems that are using the different battery systems.

### **3 BREAKER FAILURE**

#### **3.1 Introduction and Basic Concepts**

Before discussing the application considerations for implementing integrated breaker failure protection possibly in multiple relays, it is important to review some basic concepts. In a high-voltage substation, protective relays serve the function of fault detection. Each relay is typically applied to be selective to a given power system zone. To provide redundancy and eliminate single points of failure, multiple relays are often applied, typically two, to cover each zone. Backup relays on adjacent zones that over-reach the protected zone with time coordination can be used in addition to or as an alternative to using multiple relay systems.

A circuit breaker serves the function of fault interruption. For redundancy, multiple circuit breakers are not typically applied. Instead, backup for failure to interrupt a fault is provided by the breaker failure protection system. If the breaker failure (BF) protection system detects that its circuit breaker has failed to interrupt, it trips adjacent breakers to clear the fault. By definition, BF protection is a backup function. Thus, it is not necessary for the scheme design to be made fully redundant like is often done with the fault detection function. However, it might be considered beneficial if the fault detecting and BF functions are independent with respect to their input signals (current transformers and wiring), hosting relays (hardware and firmware), and tripping outputs (relay output contacts). Such a strict approach would call for placing the fault detection and BF protection functions on different relays using different CTs and signal paths.

Depending upon the bus arrangement, any given circuit breaker may be called upon to trip by multiple relays detecting faults on zones on either side of the circuit breaker. Within the context of this report, it is assumed that there are multiple relays covering each of the zones. Thus, consideration is needed into how to implement breaker failure protection when it is possible to have breaker failure functionality available in each of these multiple relays.

Another basic concept that is important to keep in mind is that security is of primary importance in designing a breaker failure scheme. A breaker failure protection system will be called upon to not trip many more times than it will be called upon to trip. And, since a breaker failure operation results in tripping breakers that will isolate all of the adjacent zones of the power system, the consequences of breaker failure false operation are usually serious.

One of the leading causes of breaker failure misoperations is inadvertently initiating the breaker failure timer. Spurious initiation often comes from testing fault detection relays that initiate breaker failure timers. For this reason, it is important to make the system design as simple as possible and to be consistent in the design throughout the substation.

Careful consideration of where the BF function will reside in the multiple relays and management of initiate and tripping paths is key to reducing the possibility of errors. For example, from the dependability point of view it would not make sense for the fault detection functions in relay A to initiate the breaker failure function in relay B and the fault detection functions in relay B to initiate the breaker failure function in relay A because it is not possible for the fault detection function of the relay to be failed while its breaker failure function is still operable. However, from the security point of view it is possible for a fault detection function to misoperate, initiate the internal BF, and cause a misoperation due to a common failure mode such as the failure of an analog-to-digital converter, the catastrophic failure of a microprocessor, or other rare events that could go undetected by the internal relay diagnostics. The effect of such co-dependency of both the primary (fault detection) and backup functions on the same current signal path and relay hardware can be eliminated by BF schemes that apply re-trip or place the fault detection and BF functions on different relays and use cross-checking. It is worth keeping in mind that relay failures or wiring problems are very rare and it is important to weigh the risk of a common mode of failure against the complexity associated with separating the two protection functions. It is also noted that the breaker failure function may be current supervised (50BF) or simply breaker position and time supervised (62BF).

Human errors during testing, such as secondary injection without isolating the BF trip outputs, belong to a separate category. When using the same relay current inputs for fault detection and BF protection, one stimulates both functions when performing secondary injection. If the BF trips are not isolated, an inadvertent trip of a large BF zone can take place. This, however, may not be much different compared with the case of the fault detection and BF protection residing on two different relays. If the breaker failure initiate (BFI) signal is not isolated while testing the fault detection relay, the BF relay can still trip the BF zone if load current is present when one of the redundant relay schemes is being tested.

### **3.2 Factors that Influence the Design**

Factors that will influence the design of the breaker failure protection system are:

- bus arrangement,
- types of fault detection relays that are being used in the system,
- preferred balance between security and dependability,
- general relaying philosophy and maintenance practice.

#### **3.2.1 Bus Arrangements**

The bus arrangement will have a major influence on how the breaker failure protection system is designed. While a description of all of the common bus arrangements is beyond the scope of this document, a distinction can be drawn in bus arrangements between single breaker arrangements and double breaker arrangements.

Single breaker arrangements include:

- Straight (ladder) bus, single breaker
- Main bus/transfer bus, single breaker
- Double bus/transfer bus, single breaker

- Double bus, single breaker

A subcategory of single breaker arrangements is between simple and complex bus arrangements. In complex bus arrangements, the connection of a single breaker can be switched between different buses. This complicates the backup tripping logic since the breaker failure protection system is required to know which breakers are connected to the same bus as the failed breaker.

Double breaker arrangements include:

- Ring bus
- Breaker and a half bus
- Double bus/double breaker

### **3.2.2** Fault Detection Relays

The other major factor is the type of fault detection relays that are being applied. With single breaker arrangements, the fault detection relays that trip the breaker typically also measure the current flowing through the breaker. For this configuration, the fault detection relays that trip the breaker can also provide breaker failure detection.

With double breaker arrangements, the current in the protected zone on at least one side of the breaker will be the summation of the current flowing through two breakers. In the past, this summation was always done external to the fault detection relay. For this configuration, the fault detection relay cannot provide breaker failure detection. With some modern relays, the currents from each of the two breakers are brought into the relay and the current entering the zone of protection is summed internally to the relay. This type of relay can provide breaker failure detection for double breaker arrangements. With this modern development, three scenarios could be considered:

- All fault detection relays that trip the breaker can see the current through the breaker.
- All fault detection relays that trip the breaker have the currents summed external to the relay.
- A combination of both types of relays tripping the breaker.

And finally, in most configurations, at least one side of the breaker is connected to a power system bus. Thus, it should be considered if the bus protection relay is a multi-restraint, low impedance type, which measures the current in each of the breakers around the bus zone. Or, if it is a type where the currents from all of the breakers around the zone are summed external to the relay (high impedance or differential overcurrent). For the former configuration, the fault detection relays that trip the breaker can also provide breaker failure detection. For the later, this is not possible.

### **3.2.3** Security Versus Dependability

With security taking precedence over dependability for BF protection, two key aspects need to be considered when selecting a BF arrangement.

Being a backup function, the BF protection may be required to use a different CT core, an independent current path, independent relay hardware, and a separate tripping path. This requirement is naturally met when using a standalone BF

relay, but can as well be accomplished on multifunction relays without a separate BF device, at the expense of extra signaling between the relays.

Dependability is directly proportional, while security is inversely proportional, to the number of operational copies of a given protection function. Predominately, one BF function is deployed per breaker, and the associated performance characteristics primarily in terms of spurious operations, are closely related to this practice. Currently this performance is considered satisfactory. A scheme with multiple BF function elements for a given fault detection function would multiply the probability of misoperation.

Wide penetration of simple integrated BF schemes with co-dependency on the common signal path and relay hardware, and with double to quadruple numbers BF elements per each breaker may significantly elevate the risk of large outages due to BF misoperations. Superposition of such outages with other stressed system conditions may lead to serious problems.

This danger can be alleviated while integrating the BF functions but at price of increased complexity.

#### **3.2.4 Relaying Philosophy and Maintenance Practice**

Relaying philosophy and maintenance practice will significantly impact the selection of a BF scheme. Factors to consider are:

- Preferred degree of security and reliance on remote versus local backup.
- Degree of integration of the fault detection and BF functions on a single multifunction relay.
- Existing maintenance/testing practice, willingness and capacity to adjust.
- Preferences with respect to simplicity and cost targets.

Figure 3.0 presents four approaches to distributing the fault detection and BF functions between multiple relays.

Figure 3.0(a) is a traditional scheme with a dedicated BF relay. Figure 3.0(b) presents a simple scheme with an integrated BF function per each fault detection function. No external BFI signals are used.

Figure 3.0(c) shows a cross-check scheme. Each fault detection function is initiating the BF function in the other relay so that a cross-check is made between detecting the fault and detecting the BF condition. This scheme calls for cross-wiring the BFI signals.

Figure 3.0(d) shows the cross-check scheme with fail-over to its own BF function upon failure of the other relay. This scheme requires cross monitoring of the relay fail safe outputs.

Figure 3.0(e) presents a solution with a single BF allocated statically to one of the relays.

Figure 3.0(f) shows an integrated and single BF but in a switchover scheme. Normally both relays initiate the same integrated BF (one internally and one externally). Upon the failure of the relay normally performing the BF function, the other relay switches to its own integrated BF element.

Of the five schemes illustrated, Figure 3.0 (b) or (e) feature the greatest simplicity. If separation of the current sensing function between fault detection and BF functions is deemed desirable, then (c) may be applied, even though it increases complexity. If the system designer wishes to cover the double contingency of simultaneous failure of a relay and failure of the circuit breaker, scheme (b) may be applied, or schemes (d) and (f) with switchover could be used with a corresponding increase in complexity.

(a) Dedicated BF relay

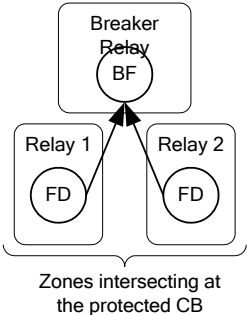

(b) One BF per each FD function

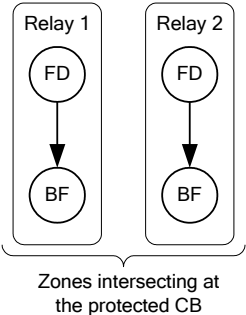

(c) Cross-check scheme

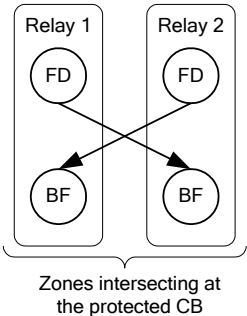

(d) Cross-check scheme w/ switchover

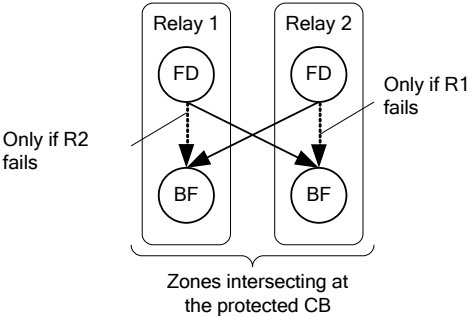

(e) Single, internal BF

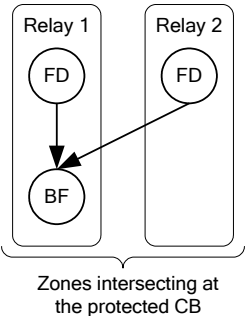

(f) Single, internal BF w/ switch-over

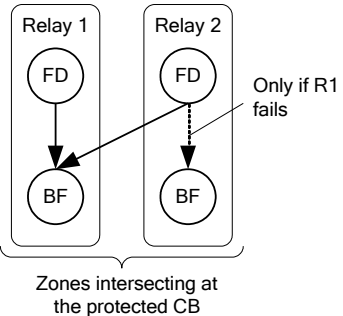

**Figure 3.0 - Possible Allocations of the Fault Detection (FD) and BF Functions Between Multiple Relays.**

### 3.3 Examples

In this section, three example scenarios are presented to illustrate some of the possible practices that might be followed in deciding how to implement integrated breaker failure protection in multiple relays. The concepts presented can be applied in other similar applications. Each example includes a number of possible relaying configurations.

- Straight (ladder) bus, single breaker as an example of a simple bus arrangement.
- Breaker and a half bus as an example of a double breaker arrangement.
- Double bus/transfer bus, single breaker as an example of a complex bus arrangement.

In all of these examples, it is assumed that the line zone has both System A and System B relays, and the bus zone has only a single relay.

#### 3.3.1 Straight (ladder) Bus, Single Breaker

The first example is a simple straight bus application. In the example, the multifunction line relays are each capable of providing breaker failure protection. On the other side of the breaker is a bus zone with a single bus protection relay. In Figures 3.1, 3.2, and 3.3, the bus relay is a multi-restraint, low impedance type relay that is capable of providing breaker failure protection. In Figure 3.4, the bus relay is a high impedance type relay that is not capable of providing breaker failure protection.

Figure 3.1 illustrates the simplest application where each relay takes care of breaker failure timing for all fault trips that it initiates (solution of Figure 3.0 (b)). There is no routing of external BFI signals. In this configuration, when a relay is isolated from the system for testing, there are no BFI signals to be concerned with. When an individual relay is out of service or has failed, there is no loss of breaker failure protection.

This configuration is symmetrical, self-contained, and simple. With no external BFI signal, the probability of a false BF trip due to human errors is greatly reduced. The probability of an internal relay failure causing both spurious fault detection and breaker fail detection is very low. As a result, the scheme of Figure 3.1 can be considered equivalently secure compared with a single BF architecture with external BFI signaling.

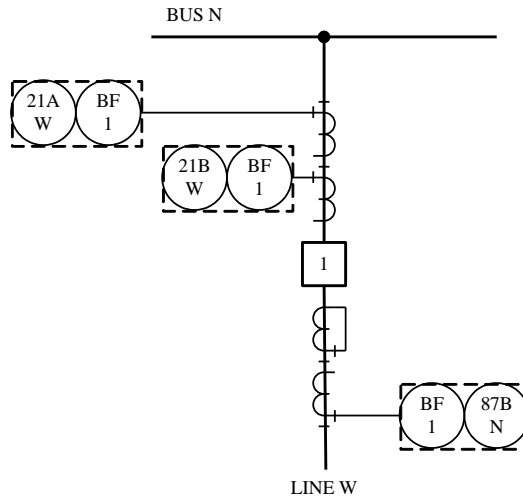

**Figure 3.1 - Straight Bus, Single Breaker, BF Implemented in Each Relay**

Figure 3.2 and Figure 3.3 are variations on the same approach. All three fault detection relays that trip the breaker are capable of providing breaker failure protection; but, the function is enabled in only one of the relays. The configuration illustrated in Figure 3.2 might be preferable since the security and trip routing requirements for a bus fault are very nearly the same as the requirements for a breaker failure. The only difference is whether direct transfer trip (DTT) of the remote breaker is available. If that is the case, the configuration illustrated in Figure 3.3 might be preferable since the line relay most likely also has direct access to the DTT equipment. In this configuration, there is external routing of the BFI signals; but the breaker failure protection function is located in a single relay. If the single relay that provides breaker failure protection is taken out of service or has failed, there is no breaker failure protection on that breaker. However, this only represents a single contingency since the primary system for fault interruption (the breaker) is still in service.

Using a switchover scheme can eliminate this deficiency. A second BF function can be configured in the B-system of Figure 3.3 as shown in Figure 3.3(a). Only one BF element is operational at any given time. The A-system BF is a default master; the B-system BF takes over upon detecting failure of the A-system relay. As such the B-system relay does not have to be initiated from the A-relay. With both relays down, the circuit is taken out of service and the BF function is not required. Extra wiring to inhibit the B-system BF from the fail-safe contact of the A-relay is required. The bus relay provides the BFI signal to both A- and B-system relays.

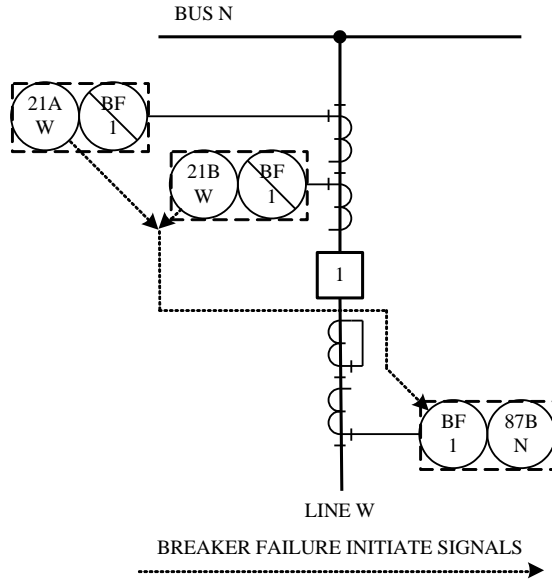

**Figure 3.2 - Straight Bus, Single Breaker, BF Implemented in Only the Bus Relay**

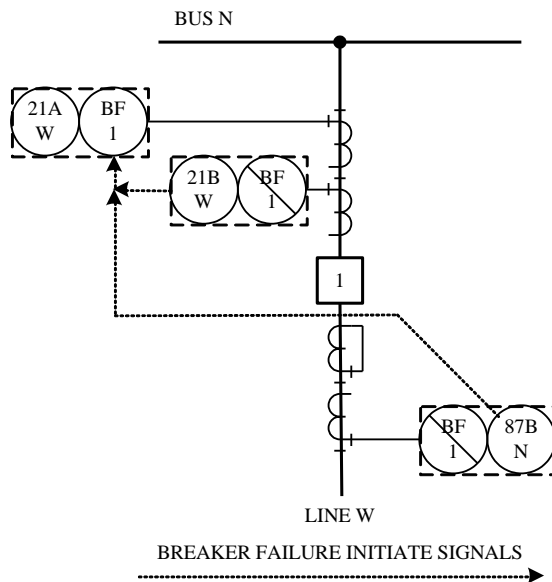

**Figure 3.3 - Straight Bus, Single Breaker, BF Implemented in Only the System A Relay**

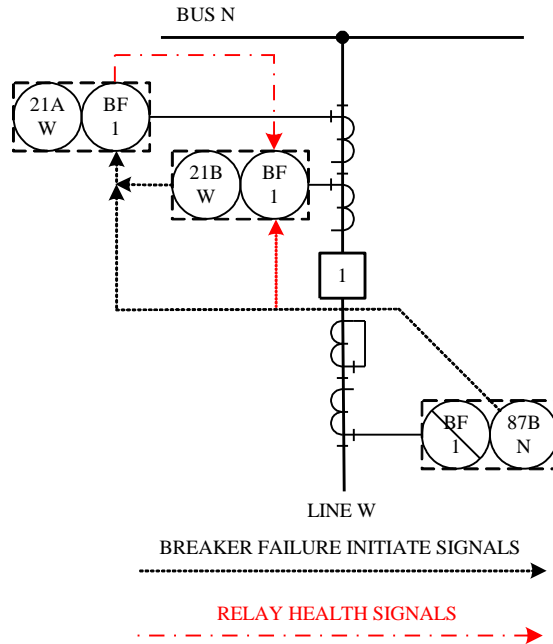

**Figure 3.3(a) - Straight Bus, Single Breaker, BF Implemented in a Switchover Scheme**

In Figure 3.4, it is assumed the bus relay cannot provide breaker failure protection. In this case, if breaker failure protection is required for bus faults, it will have to be initiated in one of the line relays. The figure shows the BFI signal going to only the System A relay. In this configuration, if that relay is out of service there will be no breaker failure protection for bus faults. Alternatively, the BFI signal could be wired to both line relays to eliminate this lack of coverage, or a switchover scheme can be implemented as explained earlier.

In cases where DTT is not available, the system could be simplified to not provide breaker failure protection for bus faults since the bus fault would have already caused tripping of all of the local adjacent breakers anyway. However, breaker failure protection for a fault on the bus would provide direct indication of the failure and simplify troubleshooting. It would not be necessary to determine if the remote relay overtripped or if the breaker failed to interrupt.

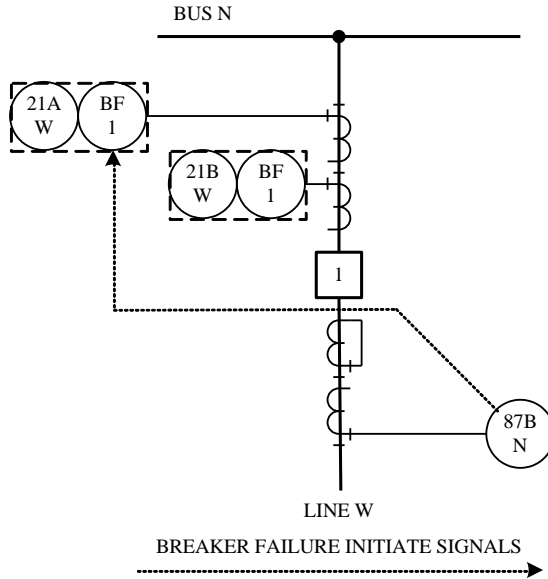

**Figure 3.4 - Straight Bus, Single Breaker, BF Not Available in the Bus Relay**

Previously described schemes exhibited a weakness of co-dependency of all or some fault detection functions and the BF function on the same CT set, wiring and relay. This could be eliminated, if required, by using a scheme with cross-checking as shown in Figure 3.4(a).

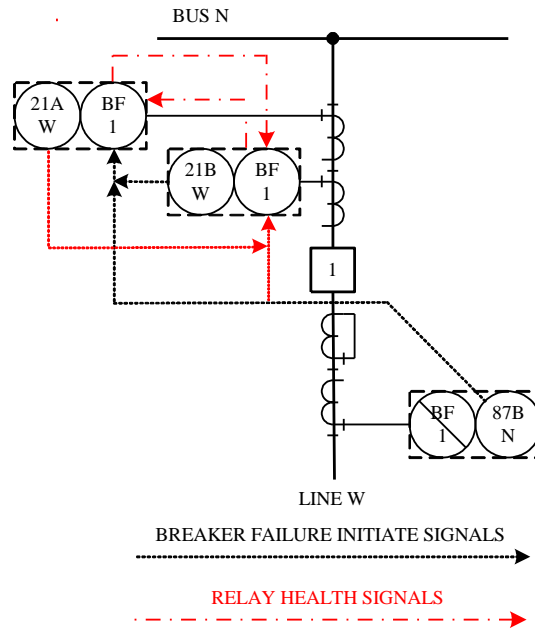

**Figure 3.4(a) - Straight Bus, Single Breaker, BF Cross-checked Between the Relays**

In this solution, with both relays operational the A-relay fault detection function initiates the B-relay BF, but not its own BF element. Symmetrically, the B-relay fault detection function initiates the A-relay BF element, but not its own BF element. Both BF elements are operational all the time, and trip independently. In this way the fault detection functions and their backup functions are implemented on independent devices using different CTs, and signal paths. With either of the relays not operational, the other relay needs to initiate its own BF element in order to maintain the BF functionality. This requires cross-wiring the fail-safe outputs between the A- and B-relays. The bus relay always initiates both of the BF elements. The condition of independency between the tripping and BF functions is automatically met for the bus protection zone.

Figure 3.4(b) shows an internal relay logic to better illustrate the principle. Identical logic is used in relays A and B.

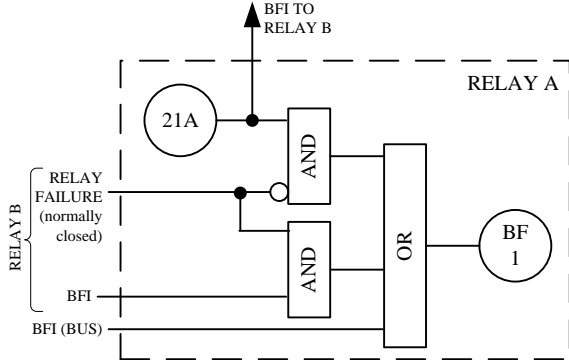

**Figure 3.4(b) - Internal Relay Logic for the Example of Figure 3.A.4(a)**

Because this solution violates the principle of separation between the A and B systems, it may face user acceptance problems. The degree of interdependency is minimal though, and the acceptance decision will be driven by a particular relay philosophy and maintenance/testing practices.

The scheme of Figure 3.4(a) eliminates the concern of a single point of failure, but still keeps two BF elements operational at any given time. The scheme may be further improved by using sensitive fault detection supervision (disturbance detectors, negative-sequence overvoltage or overcurrent, etc. commonly available on modern multifunction relays). In this approach the BF elements would not accept an external BFI signal unless confirmed by the sensitive disturbance detection element as shown in Figure 3.4(c).

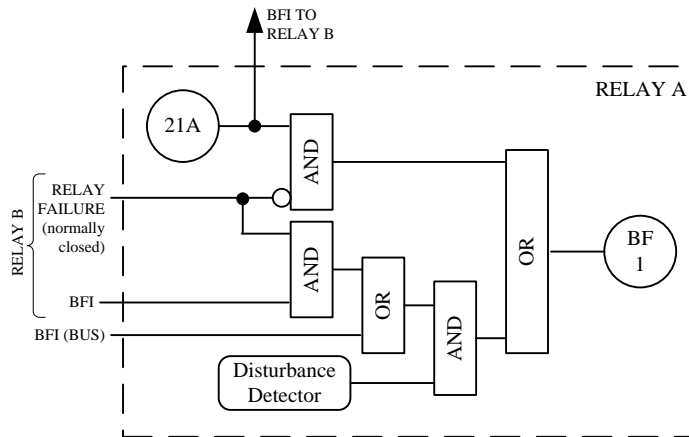

**Figure 3.4(c) - Internal Relay Logic for the Example of Figure 3.A.4(b) with Extra Security for Spurious External BFI Signals**

### 3.3.2 Breaker and a Half Bus

For the purposes of examining a double breaker arrangement, this example looks at a breaker and a half application. Figure 3.5 shows how breaker failure protection would be implemented if none of the relays are capable of providing breaker failure protection for a double breaker application. This would be a common situation where the line relays require that the currents be summed external to the relay and the bus relay is a high-impedance type. The BF function in the multifunction relays would not be used.

Figure 3.6 illustrates the simplest application where each relay takes care of breaker failure timing for all fault trips that it initiates. There is no routing of external breaker failure initiate signals. In this configuration, when a relay is isolated from the system for testing, there are no external BFI signals to be concerned with. When an individual relay is out of service or has failed, there is no loss of breaker failure protection. The scheme displays the same characteristics as its counterpart for a straight bus: fault detection and BF functions are co-dependent on the same hardware and signal paths. The solutions outlined earlier for the straight bus can be used to mitigate this characteristic if the scheme is considered undesirable, given the user's protection philosophy.

Figure 3.7 illustrates a configuration where the System B line relay requires that the currents be summed external to the relay. Figure 3.8 illustrates a similar configuration where both relays require that the currents be summed external to the relay. For these scenarios, the configuration shown in Figure 3.6 is not possible. The relay must initiate breaker failure timing in one of the relays that can provide breaker failure timing.

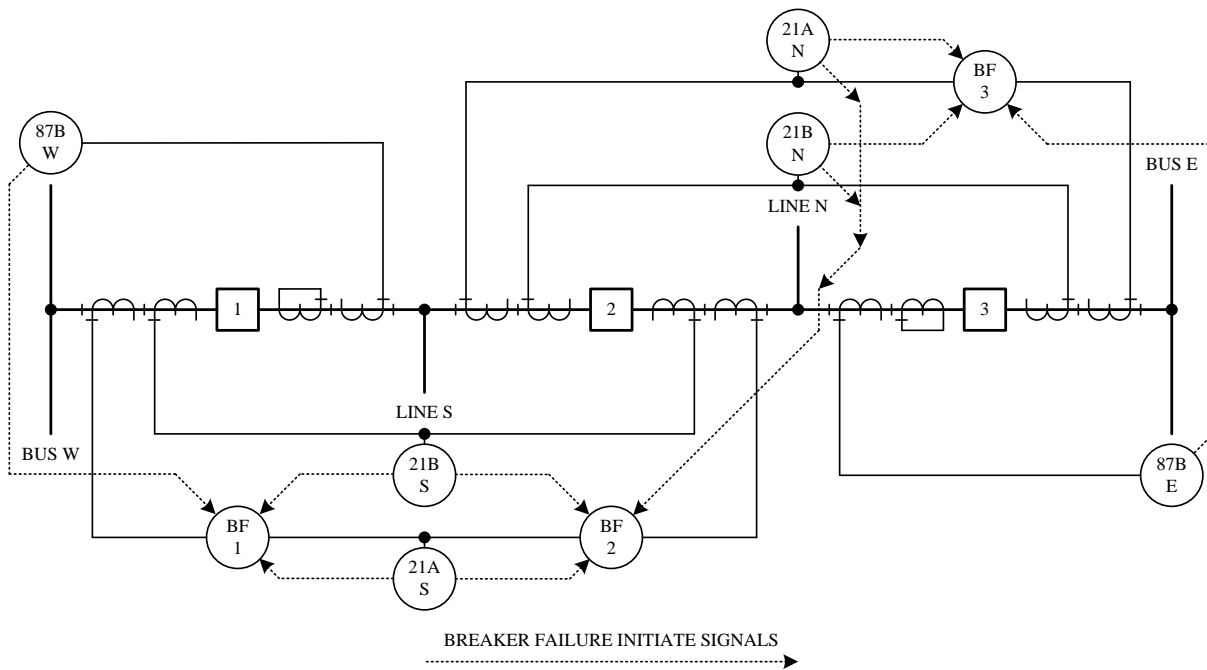

**Figure 3.5 - Breaker and a Half, External Breaker Failure Protection**

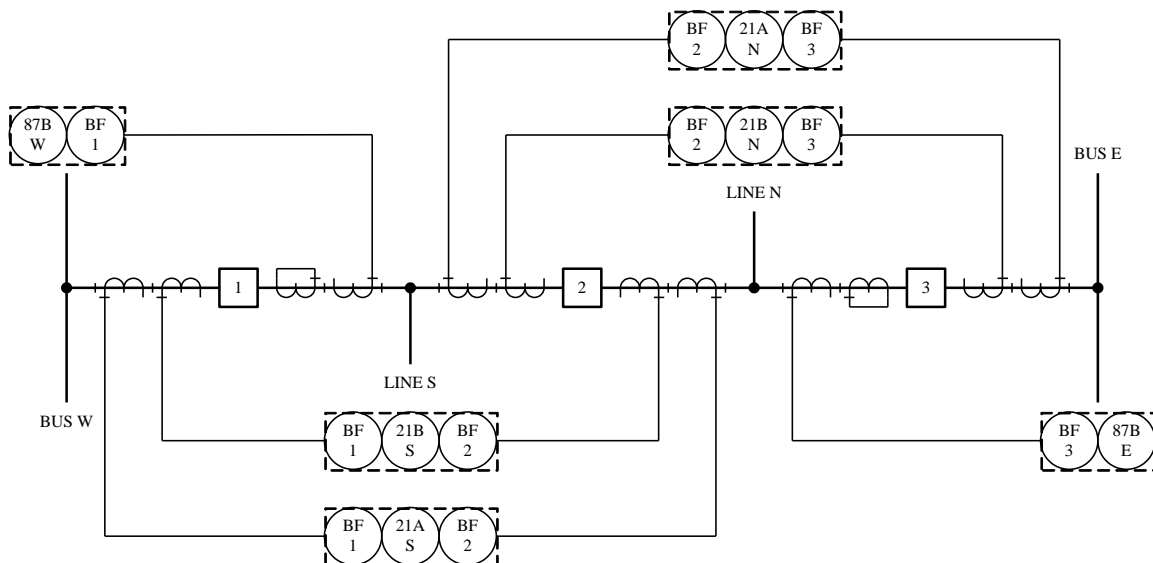

**Figure 3.6 - Breaker and a Half, BF Implemented in Each Relay**

In Figure 3.7, to simplify the application, BF protection is not used in the bus relay so that breaker failure protection for a given breaker is located in a single relay. Notice that the middle breaker in this application has breaker failure in two different relays. This is done to reduce the number of external initiates. In this configuration, if the System A line relay is taken out of service or has failed, there is no breaker failure protection on that breaker. However, this only represents a single contingency since the primary system for fault interruption (the breaker) is



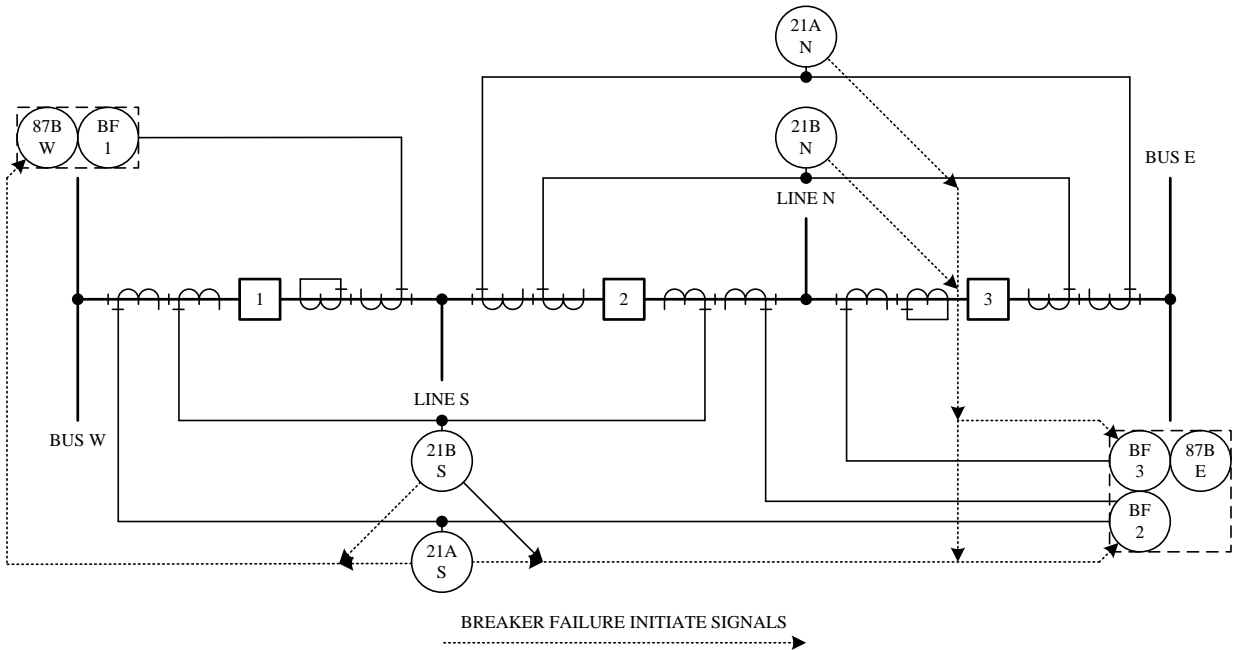
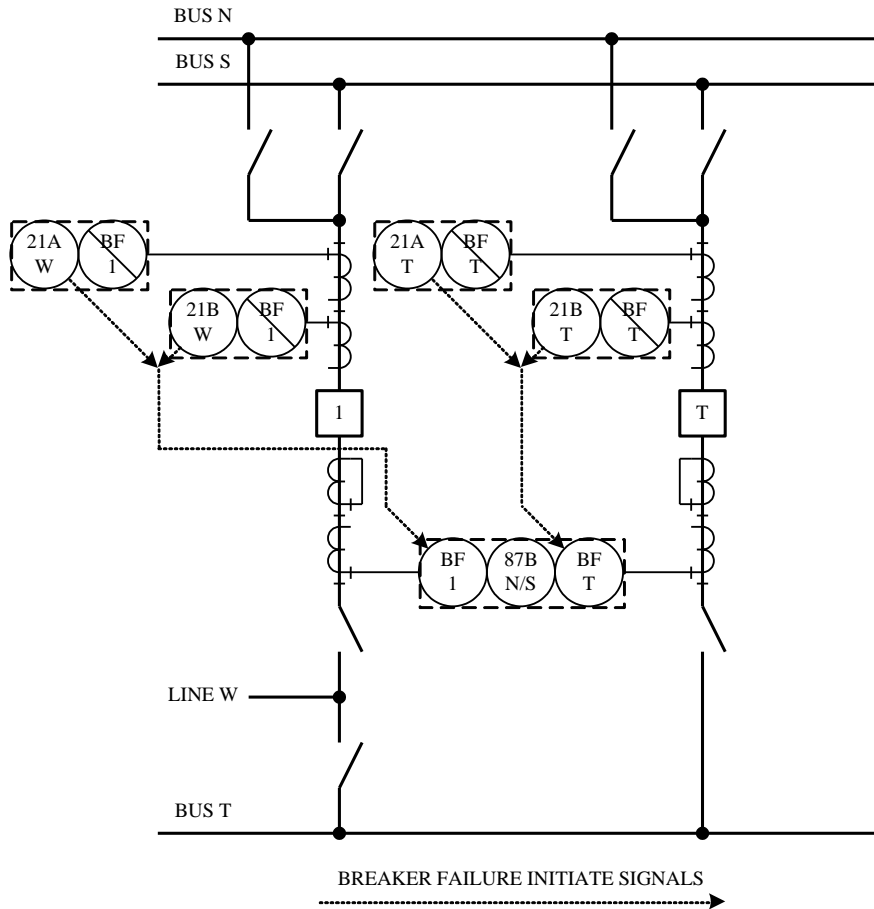

**Figure 3.8 - Breaker and a Half, BF Implemented in Bus Relay**

### 3.3.3 Double Bus/transfer Bus, Single Breaker

For the purposes of examining a complex bus arrangement, this example looks at a double bus/transfer bus, single breaker arrangement. In this arrangement, each circuit can be connected to either bus. This can make breaker failure tripping very complex since the breaker failure relay is required to know which breakers are connected to the same bus as the failed breaker is in order to backup trip the correct breakers. For bus configurations like this, the bus protection relay also requires this information in order to make up the proper bus differential zones. Due to this commonality, the breaker failure protection is often combined with the bus protection system for this bus configuration.

In Figure 3.9, each relay can provide breaker failure protection, but it is not enabled in the line relays. This configuration has more complicated external initiation paths, but the breaker failure tripping paths are simplified because they are common to the bus tripping paths. If the bus relay in this configuration is out of service or has failed, there is no breaker failure protection on that breaker. However, this only represents a single contingency since the primary system for fault interruption (the breaker) is still in service.



**Figure 3.9 - Double Bus/Transfer Bus, Single Breaker, BF Implemented in Bus Relay**

Figure 3.10 illustrates the application where each relay takes care of breaker failure timing for all fault trips that it initiates. There is no routing of external breaker failure initiate signals. This scheme would provide simpler BFI logic but more complex tripping logic. Two solutions are possible for the BF tripping paths.

In the first solution, the line relays monitor the disconnect switches to identify which bus the failed breaker is connected to, and which other breakers are connected to the bus and need to be cleared. This solution is practical only for very small buses, and when it is implemented, it is important to follow similar principles as for bus protection.

In this configuration, when a relay is isolated from the system for testing, there are no external BFI signals to be concerned with.

The second approach is to let the line relays assert the BF trip command and indicate the failed breaker to the bus relay. The latter does not perform the BF timing, but only resolves the tripping matrix for the bus configuration at the time of breaker failure.

In this approach although there are no external BFI signals, the signals sent from the line relays to the bus relay are effectively direct trips. As such it is important that they be arranged for maximum security.

In this scheme when an individual relay is out of service or has failed, there is no loss of breaker failure protection.

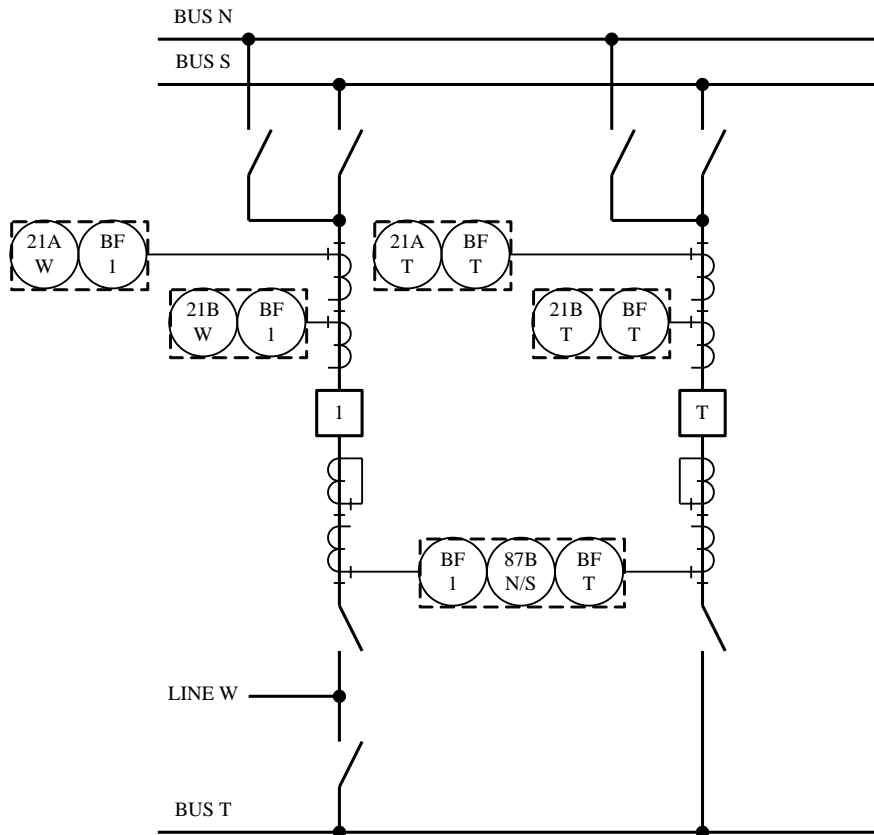

**Figure 3.10 - Double Bus/Transfer Bus, Single Breaker, BF Implemented in Each Relay**

In theory, the cross-checking solution of Figure 3.4(a) can be extended to this bus arrangement as well. Approaching the problem symmetrically one would let the line relays to perform BF function for bus faults, and the bus relay to perform BF protection for line faults. However, the security requirements for bus protection are stringent enough to assume bus trips are legitimate and the BF check does not have to be performed by an independent device. Even if the bus relay operates with no justification, the consequences are already very severe and the extra impact of unnecessary BF trips (if any) is secondary. This may not be entirely true for large multi-section buses when tripping one or more extra sections from a BF misoperation has a significant extra effect on the system.

Line relays, in contrast, may not follow such stringent security requirements as compared with bus relays. Therefore, checking for breaker failure by an independent device, a bus relay in this case, is beneficial from the security point of view. This again leads to the solution of Figure 3.9 where line relays initiate a low-impedance bus relay to perform breaker failure protection with the benefit of avoiding co-dependency on the same hardware and signal paths, and convenience of resolving the dynamic bus configuration when routing the BF trip commands.

When integrating the BF function with multifunction relays it is quite common to duplicate the function in groups A and B. This biases the scheme towards dependability at the expense of security. It is therefore important for the user to

evaluate the trade-offs between dependability and security. Like the bus trip, the BF trip is normally biased towards security. Trip zone of the BF is typically large, and therefore, spurious operations may lead to dramatic consequences (stability, loss of supply to a large group of customers).

Traditionally, security of the BF function is paramount, especially when the entire bus needs to be cleared to rectify the problem. For example, quite often the BFI signals will be wired as double point status, or by controlling both positive and negative terminals of a digital input. This is done to enhance security by avoiding spurious initiations during battery ground faults, or due to induced transients. Re-trip is another feature meant to bias BF applications toward security, not dependability.

An equivalent, enhanced security solution when using integrated BF with respect to current inputs of the relay could utilize duplicated BF functions in protection groups A and B. With both A and B relays operational, the BF scheme would work on a 2-out-of-2 basis. With one system down or cutout, the other relay would revert to an unsupervised operation of its BF function. This could be done by cross wiring fail-safe relay outputs, BFI signals and positions of relay cutout switches.

The cross wiring encroaches on the concept of separation of the redundant protection systems, and therefore may not be an acceptable solutions to some users, but it allows managing the risk created by placing two critical functions (main and BF protection) on the same intelligent electronic device (IED) hardware, and exposing them both to common failure modes.

The “BF voting” scheme may have different flavors (blocking or permissive, cross signaling via contacts or via communications, voting between A and B of the same CT or between two relays of the same group fed from CTs on opposite terminals of the same breaker).

The idea may be perceived as a novel concept, but perhaps it shall be considered given the trend to integrate more functions into a fewer IEDs and inevitably exposing the integrated functions to common failure modes.

## **4 AUTOMATIC RECLOSING**

### **4.1 Introduction**

Automatic reclosing (IEEE C37.2 device 79) is used to maintain system stability in transmission networks and to maintain the availability of power to loads in distribution networks.

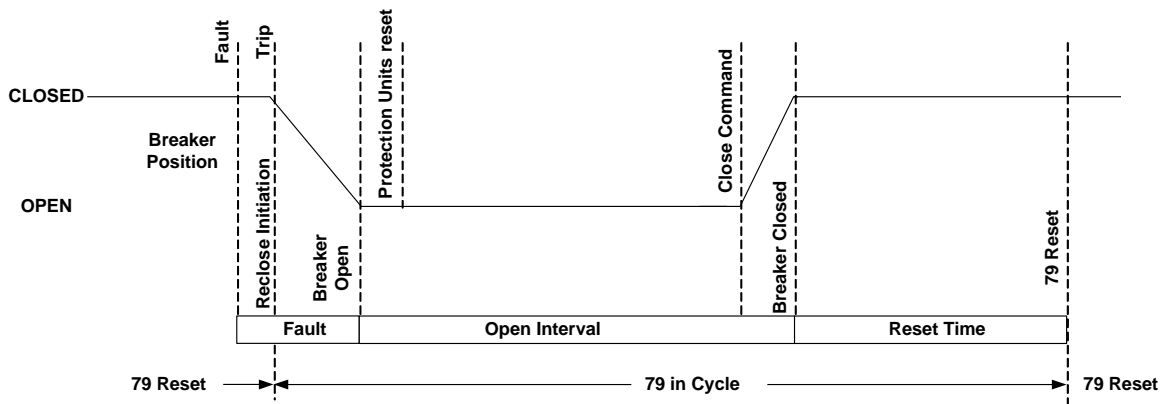

**Figure 4.1 - Breaker Contact Position and Automatic Reclosing Operation**

Figure 4.1 illustrates a single, successful automatic reclosing (AR) operation (called a “shot”). The reclosing element is ready to perform the reclosing cycle and ready for the initiation signal from the tripping relays. This state is denoted “79 Reset” in the figure, but may have other designations.

When the tripping relays initiate the opening of the circuit breaker, a “Reclose Initiation” signal is received by the reclosing element. The reclosing element activates and waits for the breaker to fully open, at which point the ‘open interval’ time starts.

The ‘open interval’ time is also known as ‘dead time’. It is the time required for the transient arc to de-ionize plus some margin to increase a chance for successful reclose. By the end of the open interval, it is expected that the fault has been cleared, and the automatic reclosing relay sends a close command to the circuit breaker.

Once the breaker has been closed successfully, as denoted in Figure 4.1 it is said that the reclose attempt has been successful. The reclosing element will start a ‘reset’ timer. At the end of the reset time interval it becomes ready for another auto-reclose cycle. The reset time is also known as the ‘reclaim time’. [6]

#### 4.2 Automatic Reclosing on Transmission Lines

The type of automatic reclosing applied on transmission lines depends on the length and number of lines connecting the stations together on the system, the physical and operating characteristics of the generators, transformers, and circuit breakers on the system, and the operating practices of the transmission system owner. Automatic reclosing schemes applied on transmission systems worldwide include three phase tripping and reclosing, single phase tripping and reclosing, and selective phase tripping and reclosing.

##### 4.2.1 Three Phase Trip and Reclose Systems

A three phase trip and reclose system trips all three phases of the transmission line for all types of faults and then automatically recloses all three phases after a specified open interval. The open interval for a three phase reclosing scheme may be as short as the minimum arc deionization time (plus a small margin) or as long as several seconds and may be supervised by the presence of prescribed voltage or synchronism check conditions.

#### **4.2.2 Single Phase Trip and Reclose Systems**

Because the majority of faults on overhead transmission lines are single line to ground faults, a single phase trip and reclose system trips only the faulted phase for single phase to ground faults. It then automatically recloses the open phase after a specified open interval. A single phase trip and reclose system typically trips all three phases for any multiphase fault, and automatic reclosing may or may not be initiated, depending on the particular characteristics of the power system.

The use of this tripping and reclosing scheme is extensive outside of North America, often at voltage levels as low as 110 kV. It helps in maintaining stability of the power system and benefits weak systems that cannot afford to lose transmission capacity, even when clearing a fault. The two healthy phases that remain connected after a single phase trip enable the generators to stay synchronized and guarantee that the network has some transmission capability.

#### **4.2.3 Selective Phase Trip and Reclose Systems**

Selective phase trip and reclose systems are not widely used, but they have been applied in some challenging system configurations. These systems trip and reclose only the faulted phases. The tripping scheme requires protection relays having an inherent phase selection capability, such as segregated phase current differential relays, and the reclosing scheme is better suited to parallel lines than single-circuit lines.

#### **4.3 Automatic Reclosing on Distribution Lines**

Because continuity of service is a high priority for distribution networks, automatic reclosing of distribution circuit breakers is often applied in multiple shots. If the last shot is not successful, the fault is assumed to be permanent, and the reclosing relay goes into the “lockout” state in which no further automatic reclosing attempts are made. Synchronism check (25) supervision of automatic reclosing is typically not required on distribution circuits because they are usually supplied from a single source.

A “fuse savings” scheme is sometimes applied to distribution circuits whose downstream distribution transformers and/or lateral circuits are protected with power fuses. In a “fuse savings” scheme the breaker is tripped by instantaneous overcurrent relay (50) before the fuse has time to blow. The reclosing relay then closes the breaker with no intentional delay, at which point it is hoped that the fault cleared. If not, the reclosing relay temporarily disables the 50 relay to allow the inverse time overcurrent relay (51) to coordinate with the fuse to clear the fault. The first instantaneous trip purpose is to save any fuse that with time coordination would have the duty to clear the fault.

#### **4.4 Input Signals to the Reclosing Relay**

Whether automatic reclosing is implemented as a dedicated reclosing relay or as a programmable function within a multifunction protection relay, several external input signals may be required for successful implementation, depending on the design requirements of the reclosing scheme. Typical input signals required by reclosing relay schemes include but are not limited to reclose initiation, breaker status (open or closed), drive to lockout, pause, and voltage or synchronism check supervision.

## 4.5 Location of the Reclosing (79) Function

The automatic reclosing element (79) in traditional systems is a separate device generally called a 'reclosing relay'. With the present technology of multifunction devices, the function is often an inherent function in a typical line/feeder protection relay.

### 4.5.1 Traditional Reclosing Relay

Historically a separate 'reclosing relay' has been provided in transmission and distribution applications.

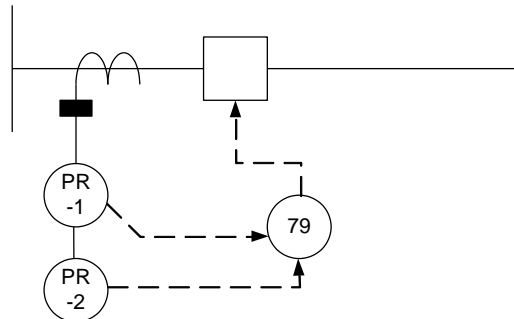

**Figure 4.2 – Separate Reclosing Relay**

This practice is still followed in many cases despite the availability of reclosing elements integrated with line/feeder protection relays. In many cases, the AR function is associated with a breaker/bay relay in a package that provides for both manual breaker control and breaker failure protection. Arguments for deploying stand-alone AR functions are simplicity and maintainability through separation of functions and natural integration with redundant tripping relays.

When using a stand-alone reclosing relay, the inputs required for AR operation are provided from the protective relays and the controlled breaker(s). In the majority of the cases, hardwired interfaces are used.

Typically stand-alone AR relays are not duplicated. This is associated with the fact that the worst case scenario is still a permanent fault calling for de-energization of the line after a trip.

### 4.5.2 Integrated Protection and Reclosing Single Device

Most modern line or feeder protection relays are multifunction devices that provide an integrated AR function. It is not uncommon in distribution networks to use a single relay for a feeder that incorporates the reclosing functionality. If a backup fault detecting relay is applied often the first relay is a full-featured sophisticated microprocessor-based relay, while the second relay is a cost-effective backup with minimum functions and often based on older technologies. If a backup fault detecting relay with no internal AR function is applied and the AR function in the primary relay is only initiated by the operation of the fault detection functions then to insure a reclose operation one of the following is done: 1) Delay the trip of the backup relay to allow the primary relay to operate and initiate the reclose operation, or 2) Hardwire the trip information from the backup relay to the AR function in the primary relay. The second design is illustrated in Figure 4.3.

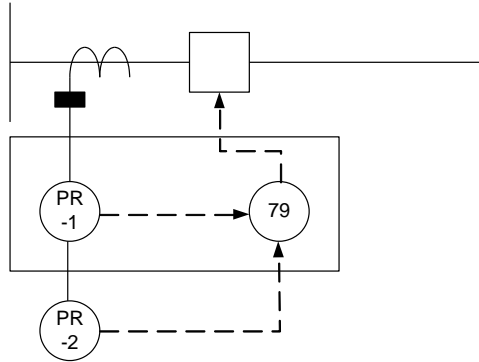

**Figure 4.3 - Single Device with Protection and Reclosing Functionality**

#### 4.6 Redundant Reclosing Relay

In many cases, full redundancy of the automatic reclosing function is not deemed necessary given that it is a control function and that failure to reclose is backed up by local and/or remote manual close. Since the reclosing function is a relatively complex sequence of steps, in cases when redundancy of the AR function is required the AR function is typically not allowed to have multiple operational instances. The AR function in one of the relays would be normally disabled. One of the AR functions is selected as the normal (master) device, and the other is enabled only if the master device is not operational. This can be done manually as explained in Figure 4.4.

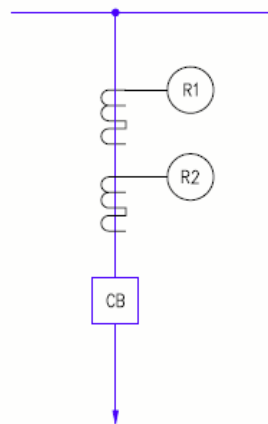

- RELAYS R1 AND R2 ARE CONNECTED THE SAME AND PROVIDE SIMILAR PROTECTIVE FEATURES.
- RELAY R1 IS DESIGNATED THE PRIMARY RELAY AND PROGRAMMED TO PROVIDE RECLOSING.
- RELAY R2 IS DESIGNATED THE SECONDARY RELAY AND PROGRAMMED WITH SLOWER TRIPPING TIMES TO ALLOW THE PRIMARY RELAY TO RECLOSE.
- IN THE EVENT RELAY R1 IS OUT-OF-SERVICE RELAY R2 CAN BE EASILY RE-PROGRAMMED USING MULTIPLE SETTING GROUPS TO PROVIDE THE RECLOSING.

**Figure 4.4 - Redundant Device Reclosing with Manual Transfer**

In Figure 4.5 the protective functions in both the primary and the secondary relay initiate the AR function in primary relay.

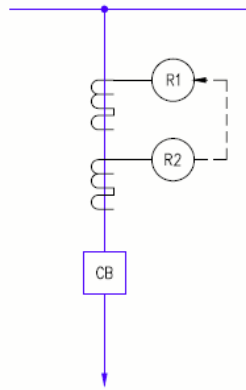

- RELAYS R1 AND R2 ARE CONNECTED THE SAME AND PROVIDE SIMILAR PROTECTIVE FEATURES.
- RELAY R1 IS DESIGNATED THE PRIMARY RELAY AND PROGRAMMED TO PROVIDE RECLOSING.
- AN OUTPUT FROM RELAY R2 IS CONNECTED TO AN INPUT TO RELAY R1 AND IS PROGRAMMED TO INITIATE RECLOSING IN RELAY R1 FOR ACCEPTABLE FAULT TYPES.
- IN THE EVENT RELAY R1 IS OUT-OF-SERVICE RELAY R2 CAN BE EASILY RE-PROGRAMMED USING MULTIPLE SETTING GROUPS TO PROVIDE THE RECLOSING.

**Figure 4.5 - Redundant Device Reclosing with Cross Initiation**

When the primary relay to normally performing the reclosing for both relays the failover of the function to secondary relay for an outage of the primary relay can be automated. Figure 4.6 shows the design to transfer the AR function to the secondary relay via the hard-wiring of the fail safe relay alarm of the master device to the secondary relay. Such a scheme can be referred to as “hot standby” meaning there is a second copy of the function, purposely inhibited due to coordination concerns, is unavailable instantly should the primary function be lost.

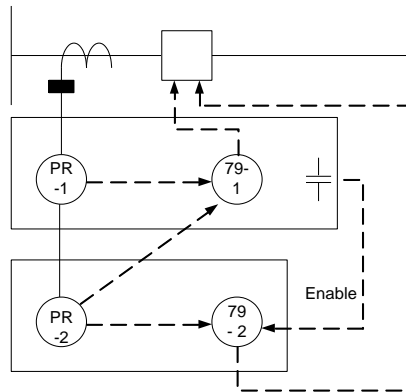

**Figure 4.6 - Redundant Device Reclosing Scheme**

## 5 APPLICATION OF OTHER CONTROL FUNCTIONS

### 5.1 Local Verses Remote

Changing the network topology to alter power flow or to isolate equipment is done at the local station, or from a remote control center, either manually by humans or

automatically by machines. Switchyard voltages, currents, and switch positions are measured and breakers, disconnects or tap changers are operated. Modern multifunction relays, applied for the purpose of protection, measure many signals, have a wide range of settings, and perform logical functions. These relays often contain extra unused embedded functionality in the form of relay elements, virtual variables, logic gates, latches, timers, or other pre-programmed logical blocks. This extra functionality could be used to replace or augment the traditional control schemes. Point to point wiring associated with the cascading device outputs of a traditional scheme might be reduced or eliminated.

Schemes that most effectively measure the conditions from only a single power station can be migrated from remote manual to local automated control. The resulting simplified schemes have fewer components that can fail (no telecommunication channel). The potential for human error is reduced. Remote arming or manual backup to this automated control may be included. One example is the automation of switching of a shunt capacitor bank to control local voltage. A relay that is applied to protect the capacitor bank can also measure the bus voltage, make a control determination, and initiate switching. This fully automatic control scheme can be removed from service at any time by a remote SCADA operator.

Other schemes that benefit from the measurement of conditions from multiple sites might take advantage of the capabilities of multifunction relays. Remote measurement of power flow, alarm conditions, and equipment status from different stations provide a broad perspective to SCADA operators and dispatchers that are making system adjustments, dispatching repair crews and establishing clearances. These relays or IEDs can be configured to measure and convert the station condition information into messages that can be broadcast or exchanged between devices over a network. They measure the same CT and VT signals as traditional transducers and they can provide inputs to measure additional alarms from nearby equipment. Contact outputs, point to point wiring, termination frames and control cables might be replaced by a fiber-optic cable or twisted wire pair connection (Ethernet or multi-drop). This local area network (LAN) could be made fully redundant and independent by design of the fiber cable system and components. A second IED also provides condition measurement in case of primary relay failure. Work clearances and tag-out procedures may be improved by incorporating latching logic and mimic representation within the local control device(s).

Protective relays might also provide station condition information and control outputs for wide area Remedial Action Schemes or System Integrity Protection Schemes. Synchronized phasors could be provided. The relays would provide this information to a centralized controller over a high speed telecommunication network.

## **5.2 Issues of Concern, Traditional Verses Integrated Manual and Automatic Functions**

It is important to maintain the ability to reliably operate breakers during critical situations. How best to accomplish the integration of controls with protective relays will require some careful thought.

In traditional breaker control, several independent devices, often electromechanical relays, are required to operate in sequence or in parallel to actuate the breaker. One component, such as a reclosing relay, could be removed from service or disabled, and other components would continue to function for example, to provide remote manual closing through an interposing relay. Physical test switches were strategically placed for isolation. High reliability of these components meant that redundancy was not typically applied, at least at the local station. It would be unusual to remove a

component from service until a failure was discovered. For remote control, some redundancy may have been provided for providing power to the RTU or for alternate routing of telecommunications.

If multifunction protective relays are used to host the controls, these relays have components that are susceptible to failure, such as power supplies and analog to digital converters. However, these relays contain self-checking features that act to prevent operation when an internal failure is detected. These features can remove the relay from service, initiate an alarm, and activate other backup controls if necessary. [1] Because the relays provide protection, they may occasionally be removed from service to change settings or to provide recalibration. This suggests the need for some form of redundancy.

The degree of integration practiced by the utility may range from fully integrated, where the relays provide not only remote and local breaker control but also status, alarm, and metering information, to partial integration where the relays provide only local automation such as in automatic transfer or isolation schemes. These situations are different and the utility must decide for each case if redundancy is needed. If redundancy has already been provided to satisfy protection requirements, the dependability, security, availability and simplicity of control schemes may be improved without much additional cost. New techniques may require changes to processes and thinking. The designer may choose to apply only certain elements from among the many that are available in order to optimize these five factors. It is important that the addition of control functions does not degrade protection performance. Inappropriate or failed control can cause equipment damage or unsafe conditions.

Control system architecture, will depend upon the breaker arrangement, the types of breakers (three phase or single phase operators), required redundancy, and the choice of which hardware platforms are to contain the line, bank, bus, or breaker failure protection. The functional capability of each applied relay may vary for a number of reasons that include relay type, time of deployment (age), replacement cost, or otherwise. The utility could choose to select and apply relays based upon their capability to provide this additional functionality. In dual breaker arrangements, each breaker may be common to more than one line, bank or bus, and several relays might be wired to trip (or close) each breaker. Capable devices may control more than one breaker. To ensure that a failure of any single component does not render the function inoperable, redundancy implies that each relay box/platform measures separate CT and VT inputs, has a separate power supply, and has separate contact outputs for each control circuit. Other components of a control scheme include instrument transformers, transducers, auxiliary switches, the control battery, and the power circuit breaker, disconnect or tap changer. Breakers may have two trip coils each with an independent control circuit that can be supplied from a separate control battery. Usually only one close control circuit is available.

P R I M A R Y R E L A Y

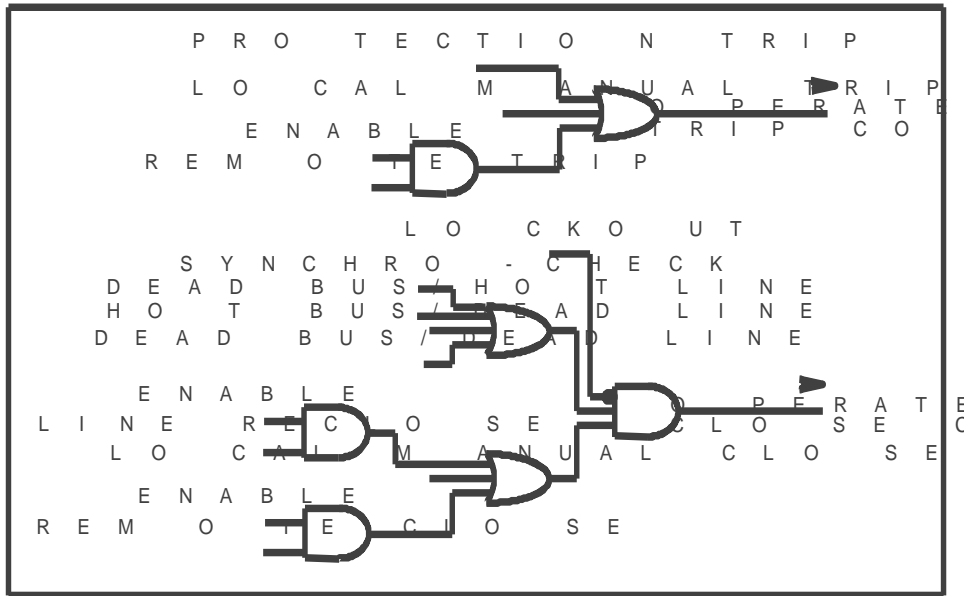

D U P L I C A T E R E L A Y

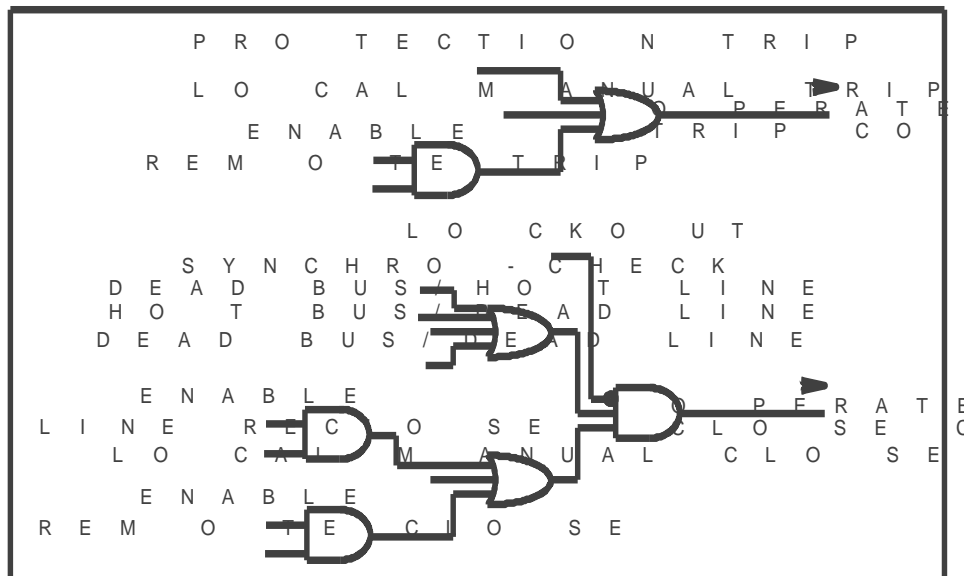

**Figure 5.0 - Duplication of Integrated Control of a Single Breaker**

A typical control circuit might require both initiate signals (ie remote trip, manual trip, reclose initiate) to start the process, and also supervisory signals (ie synch-check, lockout, reclose cancel, supervisory cutout) to enable or prevent control action should conditions change. Control outputs might be driven by a combination of protection elements, latches, logic gates, and timers. A scheme with fewer components offers better reliability (power supplies, analog to digital converters). Ideally, this suggests consolidation of switchyard condition measurement, scheme logic, initiate signals, supervisory signals, and control outputs into a single multifunction relay. The scheme

might be duplicated in a second device, as shown in Figure 5.0. If, for a particular function redundancy is not wanted, that function might be omitted from the duplicated relay scheme. In Figure 5.0 the LINE RECLOSE signal, which could be the result of complex automatic line reclosing logic, could be omitted from the duplicate control scheme. In actual practice, some external wiring may be required. For example, it may be necessary to include inputs from an electromechanical lockout relay or an external reclosing relay to the control scheme.

Once multifunction relays have been applied for the purpose of system protection, ancillary functions may be available in the following situations:

TABLE OF SITUATIONS FOR AVAILABILITY OF ANCILLARY FUNCTIONS	
SITUATION #1	Protection redundancy is established by providing two identical but independently operating multifunction relays. Each relay may contain either by default or special programming, the control function of interest.
SITUATION #2	Protection redundancy is provided by two independently operating multifunction relays, preferably each from a different manufacturer. Here, the control function of interest may be provided within each device, but the principle of operation of the control function might be different.
SITUATION #3	The control function of interest is available within each redundant relay, but it is also available within other relays that are applied for a different purpose but that also control the breaker of interest. (Pairs of duplicate relays protect lines on each side of a ring-bus breaker that also has a separate breaker failure relay)
SITUATION #4	The control function of interest is available and may be applied more than once within a single protective relay.
SITUATION #5	The control function of interest is available in only one device. (One multifunction relay is backed up by an electromechanical relay)
SITUATION #6	In a dual breaker arrangement, on one side of the breaker the utility might apply relays that do not have multifunctional capability (bus relays), but on the other side multifunction relays are applied (line relays).
SITUATION #7	The control function of interest may exist in the traditional form, external to the multifunction relays.

**Table 5.0 – Available Multifunction Relays Situations**

Adding redundancy in one part of the control circuit may or may not have much impact upon the reliability of the over all scheme. Although these functions might exist in several devices, this does not imply that each should be used. Each time a control

function is activated, special settings may be required, and a process for removing the equipment from service may become necessary. This increase of complexity, and the possibility for human error in keeping track or being aware of total functionality is usually weighed against the other benefits. The designer might apply a fault tree analysis method to each design option to analyze the different probabilities of failure for components and to help determine how to build the scheme to optimize performance. [2] It is also important to keep documentation showing the activated internal logic for each device up to date.

Typical design decisions include which type of redundancy to apply, if any, and which hardware platforms or devices will contain the activated integrated functions. Breakers typically form the boundary of a protection zone (even though the relay reach usually overlaps the breaker). Local relays that protect the equipment adjacent to any given breaker are a good choice to host the trip and close control schemes since these relays are required to trip the breaker for protection purposes. Some types of relays may have less functionality than others.

P R I M A R Y R E L A Y

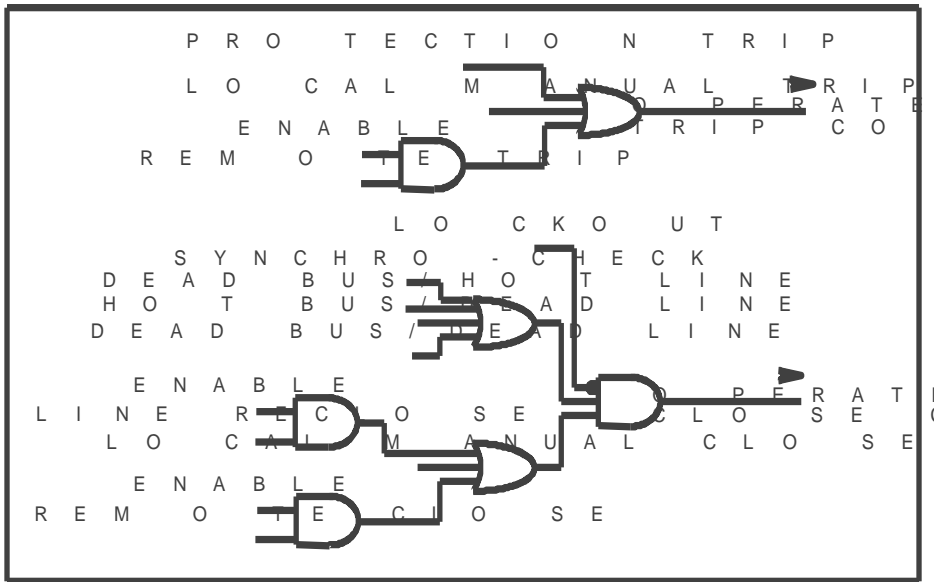

D U P L I C A T E R E L A Y

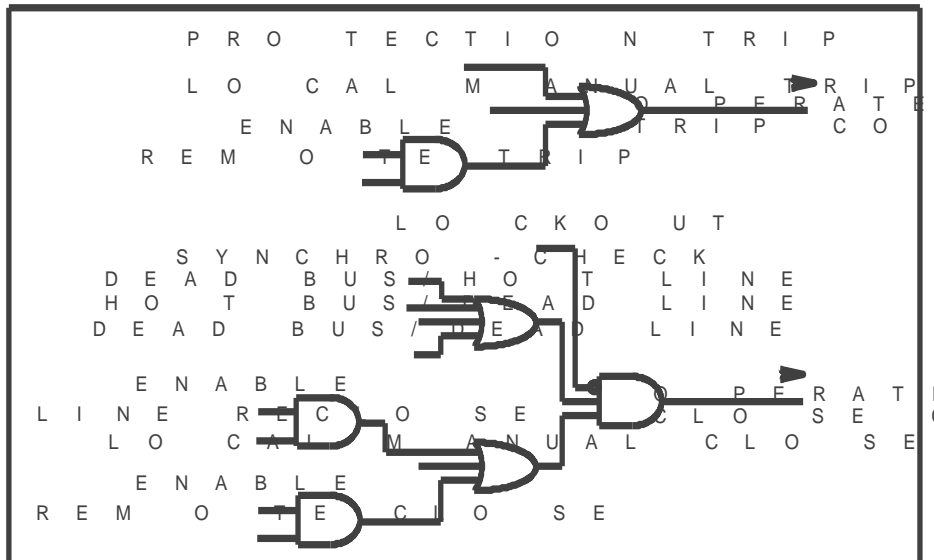

**Figure 5.1 - Duplication of Integrated Dual Breaker Control**

The possibilities become greater when dual breaker arrangements are considered. For example, in a breaker-and-one-half arrangement, to provide control for the bus breakers that separate each main bus from each line, one might choose the adjacent line relay(s) to host the breaker controls, as shown in Figure 5.2, option #1. The adjacent bus relay(s) may not have enough functionality to do the job. If dual duplicate relays were applied for each line, then the breaker controls of the primary relay could be duplicated within the secondary relay, as shown in Figures 5.0 and 5.1.

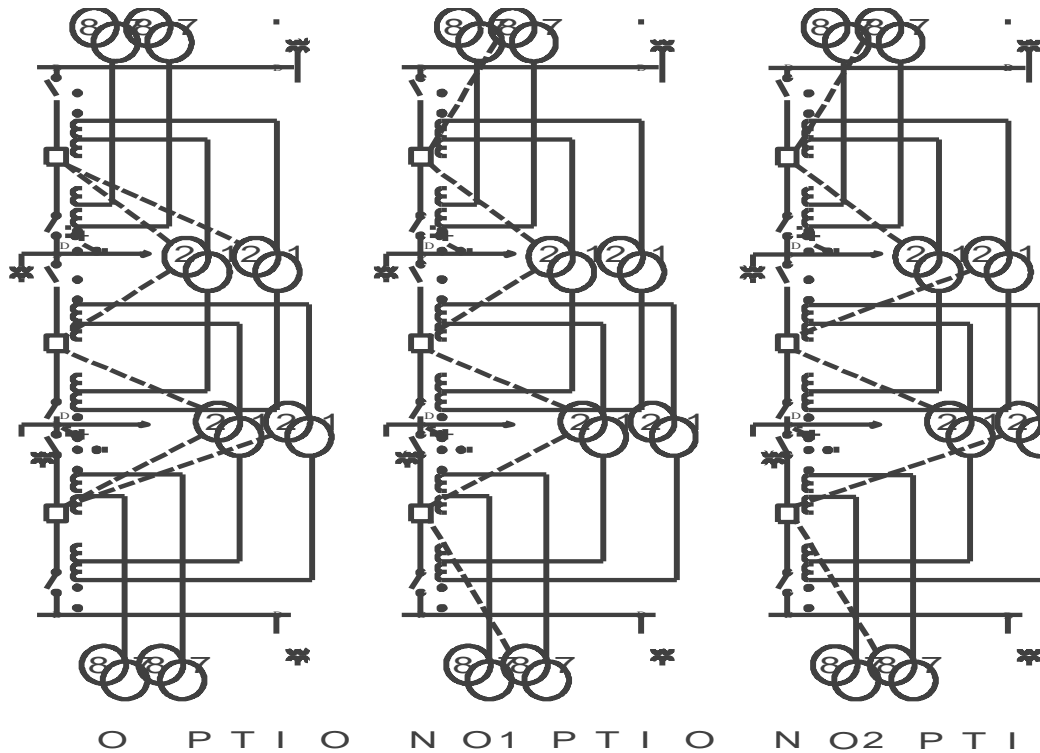

**Figure 5.2 - Options for Providing Redundant Breaker Control**

In this way an alternate control path is provided in case one of the relays is removed from service in Figure 5.2. For each middle breaker serving between two lines, one would need to decide which pair of line relays would host the control functions: the pair protecting the line on the right side of the breaker, or the pair protecting the line on the left. If each line were protected by redundant relays of different vendors (situation #2 in Table 5.0) one might choose to apply control from within only one of the two relays from each side of the breaker, as in Figure 5.2, option #2 and Figure 5.3, option #5. However, it is important to avoid having only a single relay control both the line terminal breakers without any backup, as shown by option #6 in Figure 5.3. If control scheme redundancy is not wanted, the designer may consider applying a different relay to control each of the line terminal breakers so that a common failure of the relay does not prevent loss of control of both breakers. If a separate multifunction relay were provided for breaker failure protection of each breaker then each breaker failure relay could host the breaker controls. Once a decision is made, unused functions are usually disabled and unused outputs are not wired.

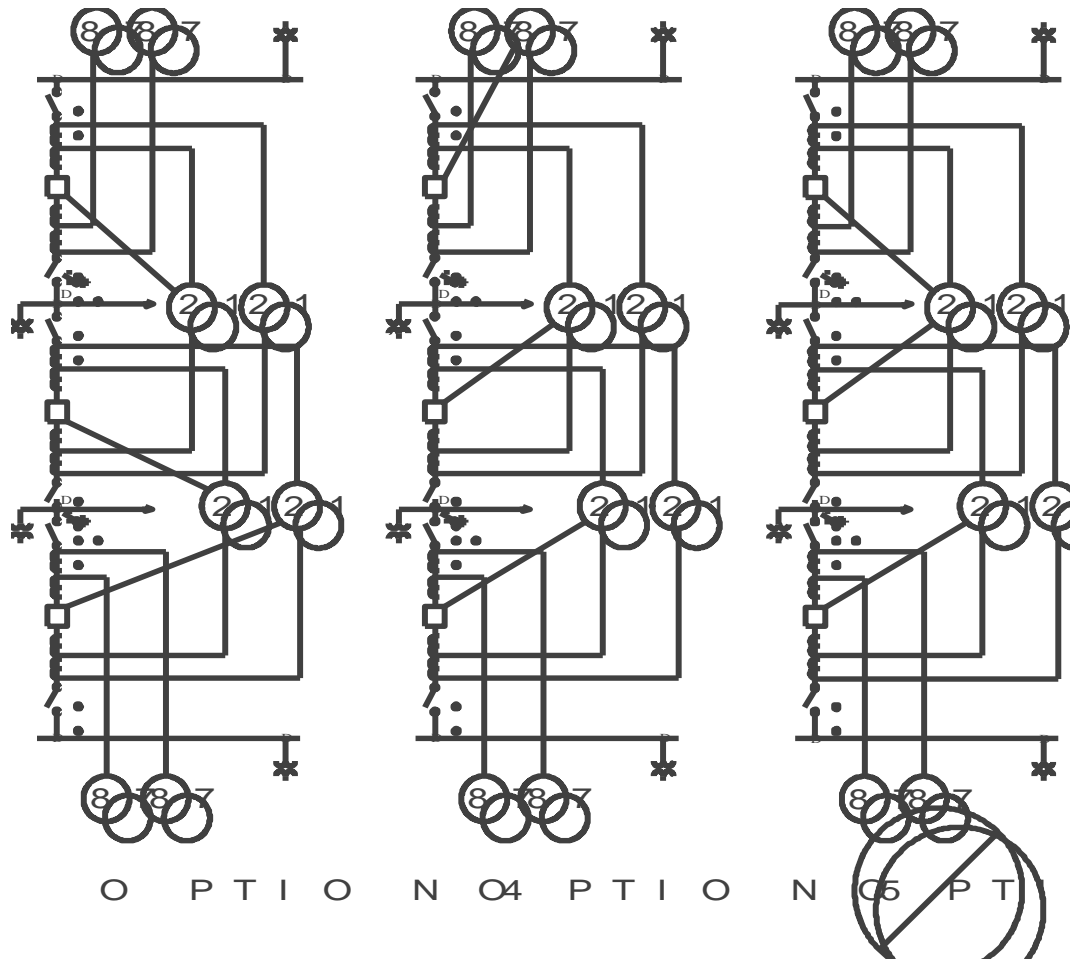

**Figure 5.3 - Control for Dual Breakers without Redundancy**

Power stations are typically designed to provide at least one alternative in case of any critical equipment failure. This is true not only for the switchyard equipment but also for the relays and control components that enable isolation or redirection of power. To optimize overall reliability, by considering performance factors such as dependability, security, availability, flexibility and simplicity, the designer may choose one of the following methods for providing alternatives.

(One intent of these figures is to show that it is possible to provide the redundant or “duplicated” breaker control from a different type of relay. For example, in Figure 5.2, options #2 and #3, or Figure 5.3 option #5, if a bus relay is used to control the breakers, then besides the usual current inputs and trip outputs, the relay will need additional inputs to measure each line or bus VT and outputs to close each breaker. )

### 5.3 Manual Backup or No Redundancy

The most secure and simple method, but least reliable or available, is to activate the control function in only one device as shown in Figure 5.3. Traditional control equipment might be used as backup. For example, SCADA remote and or local control might be applied to trip or close a breaker through the outputs of a single protective relay. If the relay fails when called upon to trip or close the breaker, or if the relay has been temporarily removed from service, then the breaker must be operated in some other way (for example, from the switchyard push button). This

could take much time if the station is not constantly occupied, and if there is a safety issue, it might cause the need to trip adjacent breakers. This could be avoided if an alternative is provided.

#### **5.4 Failover Redundancy**

In failover redundancy, (also called hot standby) two control devices are provided that operate independently and share no common elements. The control function of interest is activated within only one device or scheme at a time. When a self-checking feature of the primary control device senses a failure, it removes itself from service and activates the control function from within a secondary or backup device. The secondary device continually measures the relevant conditions and is constantly ready to function when called upon. Failover can also be accomplished manually once the primary device sends out an alarm. The failover method has several advantages. Security is maximized when only one function is activated at a time. Simplicity may be enhanced for situation #2 in Table 5.0. Here, if the function was activated within both devices at all times then, a conflicting response might be confusing to operators. If manual failover is applied, any delays reduce availability. If any type of device failure prevents the automatic failover operation, then reliability and availability are reduced. For example, a relay output contact that is closed when de-energized may help the failover operation function properly when the host device experiences a power supply failure.

#### **5.5 Parallel Redundancy**

In parallel redundancy the control function of interest is activated simultaneously within each of two (or more) independently operating devices or schemes. An output contact from each device is placed in parallel within the control circuit. Either device may initiate control action individually. In pure parallel redundancy the schemes have no common components (i.e., dual batteries, dual trip coils and dual circuits). This method increases reliability and has an advantage that either device may be removed from service with the remaining in-service device available to perform the necessary function. Simplicity is enhanced for situation #1 in Table 5.0 where duplicate, identical devices are applied. Declaration of a control output from one device might occur before the other. Complexity may be an issue for situation #2 in Table 5.0 where it is possible that a different operating principle may cause a different response. This could even happen for situation #1 in Table 5.0. Security is slightly reduced as misoperation of either device could initiate improper control. An alarm output contact or event report data might identify which device has operated at what time. A timing race might be of concern. Once the control action has been initiated by either device, the resulting change in switchyard status or condition usually resets both devices. Applying diverse functions of situation #2 in Table 5.0 can increase reliability.

As an example of parallel redundancy, duplicate IEDs, operating over redundant fiber, each measure an alarm condition. Loss of control voltage might be measured by each duplicate IED connected to trip a particular breaker. If the control voltage is lost at the same time that one of the IEDs has been removed from service, then the remaining in-service IED would sense and transmit the alarm condition to an event recorder or remote SCADA operators.

#### **5.6 Non-redundant Secure Scheme**

When security is very important, the function of interest may be activated within two (or more) different devices, with operation of both (or all) devices required to initiate a control action. Separate output contacts from each device might be placed in series in

the control circuit. This method has been applied in Remedial Action Schemes where high security is required. It has also been applied to remote control where network messages are used to prove trip and close commands to a particular breaker through a protective relay. In this scheme, two independent messages of agreement are required to be received before initiation of the control action occurs.

### **5.7 Triple Modular Redundancy**

Three independent devices in a voting scheme have been applied for transmission line protection where two out of three devices must declare an output to initiate control action.

### **5.8 Control Philosophies**

With any of the above methods, a single relay output contact might be used for both protection and control, but if necessary, separate contact outputs can be provided. Duplicate schemes within different devices may operate independently and then be combined, or duplicated scheme parts might operate independently within different devices, never being combined, yet operating in aggregate as an overall scheme. (See virtual lockout relay example, Figure 5.5) The consequence of failure or removal of the host device for each particular function is a design consideration for overall scheme performance. Once architecture is established, requirements for measurement and output circuit capacity can be determined. Output contacts are usually sufficient to maintain electrical isolation between each different control circuit.

It is important to consider maintenance or malfunction of each device. Physical switches for isolation (make-before-break), injection testing, and cutting the relay out of service may be provided at the option of the utility. Connectorized cables might be applied to the control circuit outputs for possible disconnection. Virtual switches that reside as logic elements within the IED can prevent unwanted transmission of alarms during maintenance. The test switch variable may be “set” by switching on the control voltage to a device input by the same physical test switch that is operated to remove the device from service. This test switch variable can be combined with the control logic result for each alarm or output as inputs to the AND gate function. A virtual test switch may be used to prevent unwanted alarm signals from being sent to the control center during device testing. It can be used to test changes to relay or control logic by blocking the device output. This is especially useful when the outputs are network messages. The need to trip check power circuit breakers is avoided if control wiring is not disturbed.

The expected failure rates for each scheme component may be considered if the data is available. Redundancy might be applied to a particular component if the failure rate is a concern.

An objective of a well-designed control scheme is to provide the flexibility to accommodate any future switchyard addition (line, bank, or breaker). If control schemes are imbedded within protection devices, then some method for adding future logical blocks is usually provided.

Where control schemes are imbedded and protection products are replaced, then the interoperability between different multifunction platforms may become a concern. Savings from substation integration may require compromise.

Design of internal logic may be affected by circuit peculiarities. For example, seal-in or latching may be needed so that breaker anti-pump schemes will remain operable. Delays may be required to prevent mis-operation during single phase control

operations. Maintaining the system's immunity to control circuit transients during adjacent circuit operations or faults may become a significant design problem. Sometimes these types of problems may not be discovered until commissioning and may require additional modifications to the control logic.

## **5.9** How Protection Elements Might be Applied for Control Automation

The following commonly used protection elements may be available within each multifunction relay for manual control, lockout supervision, line reclosing, automatic isolation, automatic load transfer, voltage control, and point-on-wave switching. These may be available as either pre-defined logical blocks, or as individual logical components where the pickup (logical one) or dropout (logical zero) of the elements may be used as variables to be combined in logic schemes using gates, latches and timers.

## **5.10** 25 Synch-check Functions

Synch-check (C37.2 device 25) is a function used to verify that a steady condition of synchronism exists between the voltages on each side of an open breaker before allowing the breaker to close. The voltage of a particular phase is compared to a second measurement for that phase on the opposite side of the switch. One method allows the breaker to close when the peak (phasor) values are coincident or within a given angular difference for a set time period. Another looks at the voltage difference angle and frequency (slip) to determine that these are below set values. These schemes protect breakers from closing across excessive voltage differences caused by separated systems or heavy load flow on parallel lines. Line relays, breaker failure relays, overcurrent relays and automatic reclosing relays might include a synch-check feature.

When required, local, remote (SCADA), and automatic reclose commands to the breaker may be supervised by the synch-check, voltage check, and lockout functions. How these are best applied can depend upon the degree of integration practiced, the breaker arrangement, and the available functionality of the applied relays. When remote or local breaker control is done through a protective relay output then a relay might be chosen that contains each of the necessary functions. If redundancy is desired then separate duplicate schemes could be employed where each necessary supervisory function is included within each scheme.

If the breaker supplies a line with automatic reclosing, the breaker control scheme design will be affected. In single breaker arrangements, it is only necessary to measure the condition of a single high voltage equipment position and to control and measure the single service breaker. Necessary measurements might include reclose initiate and cancellation signals from line relays, interlock signals from lockout relays, bus voltage, line voltage, breaker status, and the local and remote close command. Although there is usually only one breaker close coil, partial redundancy of close scheme logic provided by a second multifunction relay may help improve availability.

Parallel redundancy has been applied to automatic line reclosing schemes in single breaker arrangements. Each of the two line relays contain a complete, activated reclose scheme. If synch-check is required, this could be applied independently within each device. Event reports are used to determine the problem if there is a misoperation.

In dual breaker arrangements, both of the local line terminal breakers can be controlled to properly sequence reclosing after a line fault. In this case the close

control commands, the status of each breaker, the reclose initiate and cancellation signals from each line relay, and the lockout/interlock protection from equipment located on each side of the breakers is included. If synch-check is required, voltages on both sides of both breakers are measured such that three different voltage measurement locations are used to supply two separate synch-check functions, one for each breaker. A single device could host the entire local, remote, and automatic line reclose schemes for both breakers. Because of this complexity, redundancy for reclosing is not usually provided. Failover redundancy might be considered.

Some utilities control the breaker through a single monitor and control device. This is a convenient place to host the supervisory closing functions when redundancy is not needed. A separate automatic recloser relay might be applied. Others may activate reclosing within one of the line relays. Whatever the choice, it is good practice whenever possible to consolidate each of the necessary close functions within a single device to minimize scheme components. This can simplify wiring and help mitigate timing problems that might occur from the cascading of several device outputs (for example, breaker anti pump scheme interaction with the close control scheme). This can be duplicated if redundancy is desired. Cascading outputs may be necessary if insufficient functionality exists for consolidation.

As an example, a four breaker ring bus serves two local generator plants and two transmission lines. Originally at this station, four multifunction relays had been applied for the purpose of breaker failure protection, one for each breaker. Recently, it was determined that the generators could be damaged if any of the ring bus breakers were allowed to close during unfavorable conditions. A plant isolation scheme has since been added by activating a previously unused synch-check function within each of the four relays, to supervise closing of each breaker. Once either line trips out due to a fault or from a manual operation, closing is prevented if parallel loading causes an excessive voltage angle across the open circuit breaker. When a manual close or automatic reclose command is received by the breaker failure relay, if the angle across the breaker is excessive ( $>20^{\circ}$ ), then a signal is sent to the generator plant to reduce output until the angle drops enough to allow closing. The relays also measure breaker status from each plant to determine when to arm the scheme, and provide backup tripping commands to each plant breaker.

Bringing together two separate systems to create synchronism requires a higher degree of precision. By tradition, the station operator used a synchroscope to manually close two independently rotating systems together once slip frequency is minimized and phase angles become aligned, by watching rotation of the meter indicator and closing just before zero electrical degrees. An automatic synchronizer relay (also device 25) is used to parallel a large generator onto an operating power system by controlling the generator and by predicting the operating time of the breaker, closing it at the precise instant when the two systems are converging into synchronism. System restoration schemes have applied automatic synchronizing relays at strategic network locations to supervise remote manual connection of separated or islanded systems. These relays are not normally put into service to supervise closing until there has been a system disturbance or breakup.

## 5.11 27/59 Functions

Protective relays that measure voltage as part of the main protection, may contain extra voltage elements that may be used for control purposes. A device might measure two or more different VT sources from different switchyard locations. Definite time under-voltage (27) or over-voltage (59) elements can be used for close

supervision, line reclosing, automatic isolation, load transfer, and voltage control schemes. Analog voltage is used for point on wave switching. One may choose to rely on only one phase measurement, or depending upon the application, all three phases of either line to line or line to neutral voltage may be measured.

In addition to synch-check, voltage supervision includes “hot line-dead bus” or “dead line-hot bus” or “dead line-dead bus”. Here the breaker is allowed to close if voltage is present on only one side or the other of a breaker, or if both sides are dead. Programmable logic may be used to create different combinations of these conditions to supervise closing. This might be applicable on lines with remote generation to be sure the generator is off line before closing, or to verify that the remote end of the line is closed first. Suggested design methods have been provided in the previous section about synch-check.

Absence or presence of voltage may be used in isolation or transfer schemes to determine if a high voltage circuit is energized. For better security, this measurement might be combined with other logical elements such as the presence of breaker current, line current, or the status of a breaker auxiliary switch. Setting this type of element may depend upon network location. For example, a line side VT of a line that couples to a second line that shares a number of double circuit towers, can produce significant voltage from coupling of the energized line even when the line of interest appears to be de-energized and the line breakers are open. For safety purposes this can be a dangerous voltage, but for isolation or transfer schemes we are only trying to determine if the breaker is open. A 59 function attempting to determine if the breakers are open might be set to pickup just above this expected level of induced voltage plus some margin. A 27 element of a digital relay applied for this purpose would be set to this same value. If a traditional electromechanical relay is applied then the pickup to dropout ratio of the relay would affect the setting. Within accuracy limits, the pickup value of a numerical relay element can be the same as the drop out value so that  $27 = \text{not}(59)$  or  $59 = \text{not}(27)$ . Time delay before operate may be added to these elements to assure stability when response speed is not important. A close-in fault may produce zero relay voltage until the fault is cleared.

Selection of a device to host the transfer or isolation scheme may depend upon the topology of protected high-voltage equipment. Best reliability is established when an entire scheme, including switchyard measurements, scheme logic and control outputs, are consolidated into one fully integrated device. A multifunction relay that is presently applied to trip breakers within this control scheme/zone might be chosen. Other outputs to and measurements from adjacent disconnects, breakers, and instrument transformers must then be added.

Failover redundancy might be applied to improve the availability of isolation or transfer schemes. Although it is not normally practiced, parallel redundancy could be implemented.

In automatic voltage control, measurement of the station bus voltage is used to switch in or out shunt reactors (to lower the voltage that is too high, for example above 1.05 per unit nominal) or shunt capacitors (to raise the voltage that measures too low, for example below 0.95 per unit nominal). A relay applied to protect the reactor or capacitor can also control it. Similarly, a breaker failure relay applied for the reactor breaker might also include the voltage control scheme. Time delays are added so that the breaker does not toggle the reactor in and out repeatedly. Settings for delay and pickup are carefully coordinated for appropriate response. Because other voltage schemes, such as automatic load tap changers, might be operating concurrently,

interaction from the pickup levels and response time of each automatic voltage control scheme and its impact to system voltage is usually coordinated with wide area control schemes so that voltage control can be given a chance to correct a problem before more drastic action is attempted (such as load shedding or generator dropping). Provision may be made for remote or local operators to disarm the scheme in favor of manual switching if necessary. Typically no redundancy has been provided for these schemes, but it is possible to provide either failover or parallel redundancy if desired. See Annex 2 for an example.

In point-on-wave switching, the angle of voltage present on one side or the other of a switch is used to time its operation so that either closing or current interruption can occur at the proper instant to ensure that transients are minimized. This is useful for switching shunt capacitors, shunt reactors, and power transformer banks. With single pole breakers, this is done on a per phase basis. Just as for voltage control, the device used to protect the equipment might also contain the logic to control the switch. Any control trip or control close signal coming from local or remote operators would be supervised by this host device.

#### **5.12 52a, 52b Status Switches**

Line reclosing, automatic isolation, and load transfer schemes sometimes rely on auxiliary switches in circuit breakers or disconnect switches for use as position indicators. The 52a and 52b switches toggle at a particular point of travel of the main operator, and they give only a mechanical indication that may be delayed or advanced with respect to electrical interruption. Position indication for switches with single phase operators may be provided on a per phase basis and the parallel (OR gate) or series (AND gate) combination might be used to determine if the circuit is open (de-energized) or closed. Where only one of the two switch types, 52a or 52b, is available, the opposite switch type may be used to determine the desired condition. For single phase,  $52a = \text{not } 52b$ . For three phase,  $(52a \text{ series} = \text{not } (52b \text{ parallel}))$ ; and,  $(52a \text{ parallel} = \text{not } (52b \text{ series}))$ . A different way to determine if a circuit is open or closed is to measure current through each phase of the switch.

#### **5.13 50/50TD Overcurrent**

Instantaneous (50) or definite time (50DT) over-current elements can be used as logical elements within breaker isolation or load transfer schemes to determine if a circuit is open or closed. These elements verify that a fault has been cleared, or that the source has been removed, before allowing the automated operation of motorized disconnects or adjacent breakers. Disconnects are not rated to interrupt faults, or to break load, and some equipment should not be exposed to a fault more than once. Measurement can be done on a per phase basis. Where switches feature single pole operators, security may be established by verifying that all three phases are open before taking control action to restore adjacent equipment. (Or that all three phases have closed) For example, three 50/50DT elements that measure the breaker phase currents can be used to determine that a line breaker is open or closed. Each element might be set just below the expected level of current for line charging. (voltage times line susceptance). If any one of the three elements are picked up then the breaker is declared to be closed (still closed) and no further control action can be taken. For a bank breaker, the setting for this type of element might be just below the expected excitation current. Three phase voltage information might be combined with the current information to increase security. An open circuit would be indicated only when all three phases are below line charging current AND all three voltage elements are dropped out.

As an example, a breaker isolation scheme operates within and as a part of an overall breaker failure relay scheme. The multifunctional breaker failure relay measures each of the breaker phase currents. Upon occurrence of a line fault, if breaker failure is declared, a lockout function is activated to trip open and block closing of each adjacent fault contributing circuit breaker. Once the adjacent breakers have opened, only if each of the measured breaker phase currents have dropped below a most sensitive setting, is a control signal sent to open the adjacent motor-disconnects to isolate the failed breaker so that power may be immediately restored to this adjacent equipment by remote control.

#### 5.14 86, Lockout

Lockout is the condition where power equipment is removed from service by a protective relay, and operational policy requires that the equipment not be restored to service until the cause for the need to “lock out” has been resolved. Transformer bank faults, bus faults, and line faults that do not clear because of a failed circuit breaker require lockout. An electromechanical lockout relay is typically applied to trip and to prevent the subsequent manual or automatic closing of each power circuit breaker that contributes fault current into the protection zone of the protective relay that has operated.

In simple lockout schemes, where only one breaker is tripped to clear the fault, it might be possible to include the lockout function as a part of the integrated control scheme, so that extra wiring associated with an external lockout relay is avoided. The lockout function would be included as a latching function within the protective relay. Ancillary functions or programmable logic within the device(s) may be used to create the lockout function. A manual pushbutton might be included to “reset” the lockout function once the equipment has been assessed for damage or any needed repairs. ( Note: If redundant relays are applied and either relay can close the breaker, then both relays are programmed to contain the lockout function so that closing is prevented if either relay operates.)

Traditional schemes that operate multiple breakers require communication of the trip signal from the protective relay to the lockout relay. This is done with direct wiring. A given breaker might be within the control jurisdiction of more than one lockout relay. See Figure 5.4. Contacts from each lockout relay are connected in parallel to trip the breaker, and close interlock contacts from each lockout relay are placed in series to prevent closing the breaker.

Integration of the lockout function has been accomplished for multiple breaker schemes where the necessary communication between protective relays is done using network messages. If all of the protection functions that initiate lockout for a given breaker, reside in or are made available to a device, and if all breaker close commands can be consolidated, then integration is possible.

Generic object oriented substation events (GOOSE) messages, as described by the IEC 61850 standard, have been used to communicate the lockout signal from the protective relay to each breaker control device that contains the distributed lockout function. See Figure 5.5. Details about how this is done are beyond the scope of this explanation, however several concerns exist. [3]

- Is the status of each lockout function that affects each individual breaker properly annunciated?

- Are the lockout functions implemented such that each individual lockout function can be reset without affecting the status of any other lockout function?
- Is each lockout tripping function implemented such that tripping will occur for any single point of failure?
- When a control device that contains a lockout tripping function loses power, will it prevent sending an erroneous control signal and retain its state when it powers back up?

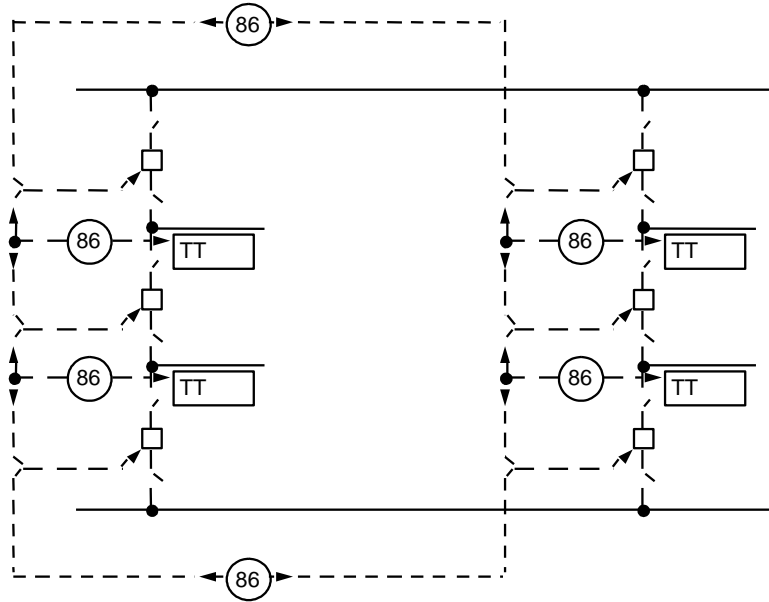

**Figure 5.4 - Jurisdiction of Lockout Function**

In a different example, integration is accomplished by applying a separate lockout function to each breaker control device (bay units) and then initiating lockout from the separate protection sources over a network connection. All close commands are routed through the control device as depicted in Figure 5.5.

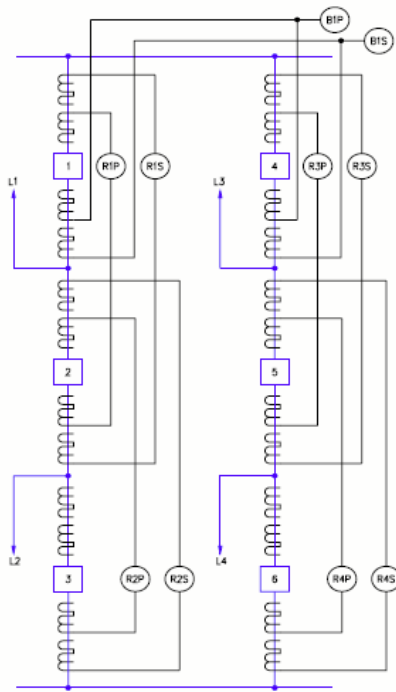

- ALL RELAYS ARE CONNECTED TO A DUAL REDUNDANT ETHERNET LAN USING FIBER CONNECTIONS.
- INTEGRATED STATION USES HMI CONTROL WITH NO PHYSICAL CONTROL SWITCHES OR LOCKOUT RELAYS (EXCEPT BREAKER TRIP).
- EACH LINE RELAY PROVIDES DUAL BREAKER TRIPPING, BREAKER FAILURE RELAYING, AND CLOSE BLOCK/LOCKOUT OPERATIONS.
- EACH PRIMARY LINE RELAY PROVIDES DUAL BREAKER CLOSE, RECLOSE, AND SYNC CHECK OPERATIONS.
- REQUIRES A CONSIDERABLE AMOUNT OF TIME TO PROGRAM THE RELAYS FOR PROPER COMMUNICATIONS.
- DIFFICULT AND TIME CONSUMING TO TEST, COMMISSION, AND TROUBLESHOOT.

**Figure 5.5 - Integrated Protection**

In a distributed lockout scheme, the lockout function resides within each breaker controller for each breaker within that lockout's functional jurisdiction as shown in Figure 5.4. A GOOSE message could be used to initiate or "set" the lockout function within each controller. This message would be broadcast over the local area network that is monitored by each controller. GOOSE message, exists within the Utility Communication Architecture (UCA) and also the International Electro-technical Commission (IEC 61850) standard as a mechanism to exchange digital/binary input or output status information of a protective relay function via asynchronous peer to peer reporting for the purpose of issuing trip operations to appropriate equipment.) This message would originate as a protection trip from an IED configured to protect for breaker failure or bus or bank faults. Each controller device within the jurisdiction of a particular lockout function would subscribe to the appropriate GOOSE messages that would originate as a broadcast from an IED.

Failure of the lockout function can result in failure to clear a fault or in inadvertent closing. Depending upon the initiating event, the particular locations that are required to lockout can be compared. An alarm might be sounded when any particular device in the scheme is in disagreement. Each device lockout function within a given jurisdiction for a particular event is expected to match all the others, either all "set" or all "reset".

In Figure 5.4 the control of each bus breaker is supervised by two lockout functions, one for the bus and one for the adjacent line. Pickup of the bus lockout function is caused by a bus fault or any bus breaker failure. Pickup of the adjacent line lockout function is caused by failure of either local line terminal breaker for that line. Control of each middle breaker is therefore supervised by the two adjacent line lockout functions.

Where redundant close (trip) schemes are applied, the lockout function is active and present within each device to trip and block each close command intended for the

breaker. Where several devices operate independently as separate parts of a lockout scheme, then each device within the jurisdiction (lockout zone) for a particular protection event is enabled to be aware of any protection trip to lockout.

The case for separate devices for each breaker might be called a “distributed” lockout function. In this case the protection signals that initiate activation of the lockout function may reside in other devices within the station, and it is important that these signals are reliably distributed to each breaker controlling device. Once the need to “lockout” is declared by a protection device, then a signal is sent to each breaker control device within the jurisdiction for that particular protection function/zone which has operated. (Notice the example shown in Figure 5.4, where there are six different lockout jurisdictions each shown by the traditional lockout symbol (86), and control for each breaker is supervised by two different lockout jurisdictions. Each fault contributing breaker within the jurisdiction for the particular event has been pre-identified. This could be done using a unique bit name for each jurisdiction or lockout zone. The control device for a given breaker might have two different latch functions, one for each lockout jurisdiction/zone that trips and supervises closing for that breaker. In modern schemes this signal communication might be done over a local network connection. If manual reset of the lockout is required, this may be done by a pushbutton located on the initiating device. (Some utilities allow automatic reset after time delay (10 seconds) for breaker failure or bus faults) This device would then transmit the signal to reset each of the devices that have been locked out. As an alternative, pushbuttons could be located on each distributed device that holds the lockout function.

Techniques that assure best reliability of communicating the activation and reset signals of the lockout function, over the network, are beyond the scope of this explanation. Depending upon individual utility practices, integration of the lockout function may or may not be practical and each utility must decide this for them-selves.

## **6 EVENT AND FAULT RECORDING**

Event and fault recording are helpful tools when analyzing faults on the electric system. Most microprocessor relays provide these tools in some form or fashion. In the situation where multiple relays are used for protection and control a protection engineer can choose to retrieve event or fault data from multiple sources. Some protection engineers use the event and fault recording tools from the relay they are most familiar with. The ability to compare records from several sources, however, may prove useful. Different relays handle several issues such as frequency response, record length, triggering, record storage, setting files, software, off-nominal frequency, and other issues in different methods. One may be able to gather more information by gathering information from multiple relays. To obtain the full benefit of these comparisons it helps to have the relays time synchronized. The usage of an IRIG-B signal from a global positioning system (GPS) time source can provide the time synchronization.

Another useful method to ensure more data is collected during events is cross-triggering or cross-initiation. Cross-triggering or cross-initiation is the function where one relay senses an event and sends a signal to other relays so they can begin their event and fault capture as well. The benefit is that all relays provide data so that analysis can be more complete. The cross-triggering or cross-initiation can be accomplished by hard wiring an output of one relay to the input of other relays or it can be accomplished by peer to peer communications.

Applications where this can be particularly helpful are where two relays are providing protection for the same zone, such as primary and backup or Set A and Set B relays on a

line terminal, transformer, or bus. Having data from both relays can often be of assistance in trouble shooting if one of the relays operates falsely or fails to operate. Comparison of the two sets of event reports also provides an opportunity to verify that current and voltage signals are interpreted consistently in both relays, and allow identification of CT or VT connection errors or setting errors even if both relays operated for a fault.

## 7 TESTING AND MAINTENANCE

Microprocessor relays have a great advantage over electromechanical relays because they are self-monitoring. Microprocessor relays have self-monitoring features that provide alarms for critical failures such as failure of the processor or power supply. In addition, some microprocessor relays have alarms for communications failure between relays, for disagreement of the auxiliary contacts on the isolator and bypass switches and for failure of a CT. This last one is very important since it can identify a failed CT before the scheme is called on to operate.

Calibration of digital relays is usually not required since there are no adjustments to be made. There are no trim pots, switches, or selectors to make settings and adjustments within the relay. If the relay does not operate within tolerance there is no way to adjust it, so calibration, as the relay users know it, is not needed. However, each relay is normally tested periodically to make sure it is operating properly. Secondary injection is used for this type of test, and the output contacts are monitored to confirm proper operation.

So overall the frequency of maintenance can be reduced for microprocessor relays due to the self-monitoring. However, the use of many functions in one microprocessor relay can create issues with maintenance testing. In the past, single function relays could be removed for maintenance testing and the circuit would still be protected by other relays. Therefore the circuit would not require clearing. For instance, a circuit protected by four overcurrent relays (three phases and neutral) could have one of these relays removed for maintenance and the remaining relays provide protection. The maintenance of one microprocessor relay could remove needed protection for a circuit. Therefore the circuit may have to be cleared. Clear documentation is needed to ensure proper protection is maintained during maintenance. [4]

In the lifetime of microprocessor relays, these may be the testing phases:

- **Acceptance testing:** New relays subject to known currents and voltages and metering per their published tolerances.
- **Detailed / Evaluation Testing:** Laboratory testing of a sample to completely understand the functionality of the relay. In this testing the user gets comfortable with the characteristics of the protective relay and learns about its design. The typical example is the plot of impedance characteristics of the distance units for distance relays. Moreover, the programmable logic of the device is tested and evaluated per the application requirements.
- **Commissioning Testing:** This would be the verification of functionality desired in the scheme. An example would be a quick Zone-1 trip and the correct operation of the output contacts of the relay. There is no need for a detailed laboratory type testing as described above. It is assumed that the proper CT and VT polarities are also checked in this procedure.
- **Maintenance Testing:** This is a periodic testing of the relay. It may be every year, every two years, etc. depending on the user's confidence on the device. This is mainly the

verification of proper measurement of the input voltages and currents and the individual operation of the output contacts verifying that these are operational.

## **7.1 Testing Issues**

Commissioning multifunction digital relays that perform protective and control functions offers some unique challenges to the user. Multifunction relays have protective functions that interact with each other, making testing more complicated. They can also be programmed to do control logic, which is also required to be verified. In addition, digital relays can have multiple setting groups, that may be switched to address varying system conditions. This flexibility increases the commissioning complexity. Due to the increased complexity it is important for the user to fully understand the schemes and how they interact. The simple testing of an overcurrent function could trigger a breaker failure scheme. Therefore, thorough documentation of the schemes so that those who test the relays completely understand the system is a of great importance. In addition, there are several other items that need to be addressed.

### **7.1.1 Disabling Settings for Testing**

When testing multifunction relays, certain setting elements may need to be disabled to accommodate steady state testing. For example, a simple 50/51 relay has both time (51) and instantaneous (50) elements programmed to the same output contact; it will be necessary to disable the 51 element to get an accurate pickup value on the 50 element. Making changes or temporarily disabling in-service settings after they are loaded into the relay requires that these setting be changed back. This may be risky because there may be dozens of settings that need to be changed and human error is a possibility. The preferred method is to begin by down loading a copy of the in-service settings in the relay to a computer disc and disable elements for testing as the need arises. When the testing is complete, instead of trying to reverse all the changes, load the original copy of the in-service settings back to the relay. In applications where the same scheme will be used over and over it may be more convenient to create a setting group used only for testing. In this setting group the relay set points can be the same as the in-service group but with elements programmed to individual output contacts where needed for testing.

### **7.1.2 Testing Setting Group Change**

Most digital relays have four or more setting groups; however, in most applications only one or two setting groups are used so the others could be left empty having no settings at all. If the relay is inadvertently switched to an unused setting group, the relay would essentially be out of service. To avoid this, the normal or default in-service group settings are often copied to all other unused setting groups. If the relay is switched to one of those groups, it will still be in service with normal settings. When more than one setting group is used, the default settings may be copied to all of the unused groups.

### **7.1.3 Testing Programmable Logic**

Multifunction relays have, in one device, the equivalent of several single function relays that would be found on the traditional relay panel, including remote terminal unit (RTU) functions. The functional schematic of the traditional relay is determined by the wiring from one device to the next. In the digital relay the programmable logic takes the place of the wiring. Therefore, it is important to

treat the programmable logic the same way as the switchboard wiring in terms of the commissioning and documentation.

Figure 7.0 shows a typical programmable logic scheme. This is the level of detail required on the schematic diagrams to properly document programmable logic for functional testing and maintenance. Every feature of the logic is usually tested to confirm that all inputs, outputs, relay function blocks, controls, alarms, and logic perform as intended and do not operate with unintended consequences. The sequence of events feature of digital relays can be used to help sort out the results of logic testing to confirm that the proper elements are asserted, logic has functioned correctly, and timing is proper.

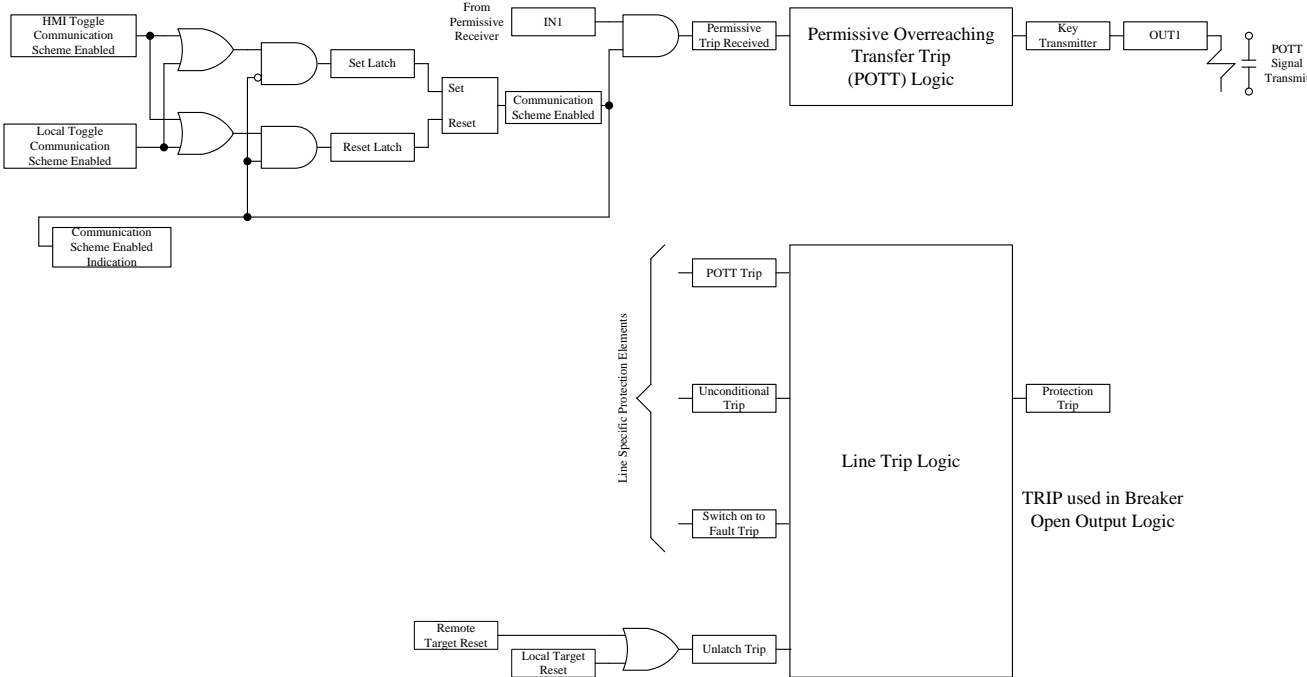

**Figure 7.0 - Programmable Logic**

**7.1.4 Testing External Inputs**

Digital relays use programmable inputs (IN1 in Figure 7.0) to allow the user flexibility in designing trips/alarm output circuitry logic. These inputs are used to monitor breaker positions or can be activated to change digital relay trip/alarm logic. Optical isolators are used within the relay to prevent external surges from damaging the digital relay components. Two types of external programmable inputs have been used by manufacturers—internally wetted and externally wetted.

Externally wetted programmable inputs use an external source of DC voltage while internally wetted programmable inputs use an internal relay DC source. When using externally wetted programmable inputs on ungrounded battery systems it is a good practice to confirm that the inputs will not operate for a full positive or negative battery ground (half voltage). After testing these inputs for proper operation at normal battery voltage, the test may be repeated at half battery voltage to confirm that the externally wetted contact will not operate.

Some relays have internal jumpers used to set the wetted contact pickup threshold to enable them to be set at greater than half the battery voltage, but less than the minimum expected voltage. If settable jumpers are not available, it is important to document the results so maintenance personnel will know that the inputs may be falsely triggered for battery grounds.

For internally wetted programmable inputs, each input is usually checked to verify that it will operate when the external contact is closed. If wiring from the contact to the relay is long, there may not be enough current to pick up the input. Many manufacturers provide guidance as to wiring distance limits.

#### **7.1.5 Testing Targets and Output Contacts**

The output contacts of a digital relay are usually individual sealed relays rated for 30A tripping duty. However, they will break less than 1 amp and will be damaged if opened while trip current is flowing. The output contacts are initiated by the internal trip logic of the relay and are independent of dc trip current. To avoid damaging output contacts used for trip and close duty, the manufacturer may supply a “hold-up” circuit that will allow the output contacts to remain closed for at least 10-12 cycles regardless of what the logic is doing. Once a trip or close has been initiated it is important that logic be included to cause the contact to remain closed long enough to complete the circuit breaker operation. Consider confirming the proper functioning of this logic during the commissioning process .

#### **7.1.6 Using the Digital Relay as a Commissioning Aid**

Most digital relays display the measured input currents and voltages as well as calculated metering values that can be used to assist in relay testing. It is good practice to check the display against known inputs by applying secondary injection quantities before using the display for this purpose. If phase angle information is not available from the display, an external meter may also be used during this test.

Since most digital relays can calculate negative sequence currents the relay can be used to confirm phase sequence. The metered value of the negative sequence current may be read during commissioning. It should be low for balanced load conditions. If not, check the phase sequence relay setting and CT wiring.

Almost all digital relays have oscillography that can be used during commissioning to provide additional information, and the relays are normally set to record an event any time there is a trip. Displaying the event after a trip can quickly reveal problems with CT polarity and phasing.

#### **7.1.7 Checking Directional Relay Polarization**

Verification of directionality of phase (67) and ground (67N) directional relays requires injection of operating current as well as to the polarizing quantity (current or voltage). The phase angle relationship between operating current and polarizing quantity determines relay directionality. The relay manufacturer normally identifies trip direction on the relay wiring diagrams so that the user can establish proper relay directionality to verify that the relay is connected properly.

#### **7.1.8 Firmware Revisions**

It is a good practice to document the firmware revision level on the settings file for each individual relay. It may not be necessary to upgrade every relay to

implement a new feature or to fix a software problem. Many changes are “bug” fixes that do not adversely affect the protective or control functions of the relay. In general, firmware updates are mandatory only if a mis-operation of protection or control functions may occur. By tracking the changes, a decision can be made if the new feature or bug fixes are absolutely needed. Keeping track of the firmware in each relay will help the user to avoid visiting every relay if a change must be made to all relays before or after a certain firmware level.

When new firmware is installed in the relay, it may be necessary to perform all commissioning tests again. In many cases, changes to the software will be minor, but re-commissioning confirms that there were no unintended consequences of the firmware change. For this reason, firmware changes are made only when necessary.

## **7.2 Documentation**

### **7.2.1 Introduction**

A protection and control system cannot be built, operated and maintained without adequate design documentation. The present state of the art numerical IEDs used substation designs accommodate traditional functionality and provide numerous functionalities that can be used or disabled based on the requirements and overall functionality desires in the substation.

Most IEDs in substation design provide some form of programmable logic that makes it easier to implement protection logic functions in the same IEDs without the use of external auxiliary relays used in traditional substation design. Some IEDs provide sophisticated functionality that allow even programming of sophisticated protection units. The clear description and documentation of these two functionalities is important understanding that in the substation several IEDs can easily implement the functions.

Wiring diagrams in traditional designs described the functionality of the signal that each wire carried for control and protection. Trip outputs wired to trip coils clearly indicated the user which protective functions operated the breaker, for example. With modern communication techniques now present in the substation, the wiring diagrams are not totally self-descriptive anymore. Serial communications in metallic communication cables or fiber optic can carry several signals that a wiring diagram may not easily self-describe. Some serial communications techniques incorporate a logic processor where several protection and control functions are implemented. With Ethernet networks in the substation and the proposal of substation protocols designed to carry protection and control signals, the description of the signals is not that simple.

### **7.2.2 Documentation Issues of Protection and Control Functions in an IED**

Most IEDs in substations will come with pre-programmed, hard-coded protection and control functions. It is desirable that these, together with the programmable logic possibilities of the IED are documented in the design of the substation.

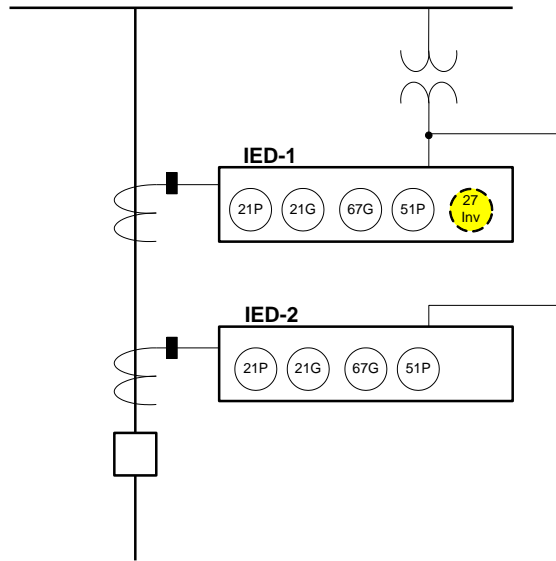

**Figure 7.1 - Example of a Custom Protection and Control Function in a Single Line Diagram**

Figure 7.1 illustrates the traditional functionality description in single line diagram generally provided in the substation drawings. Protection functions implemented in the IEDs by the manufacturer are usually shown in the diagram with their corresponding device numbers. When a custom programmed protection function is created in the device (using the device’s programmable logic) it can be shown in the same diagram with some particular marking, denoting that the function is implemented with the programmable logic of the device. In the figure, an inverse under-voltage unit, which is rarely included in an IEDs functionality and denoted by “27 Inv”, is shown in the one line diagram. Other examples of protective functions implemented with programmable logic include BF units when they do not exist in the IED, voltage controlled over-current units, directional controlled inverse-over-current units, etc.

Programmable logic in IEDs can simplify the amount of auxiliary relays and wired logic needed. Documenting internal logic used in the IEDs is done to provide better understanding of the interlocks, control sequences and protection logic implemented in each IED.

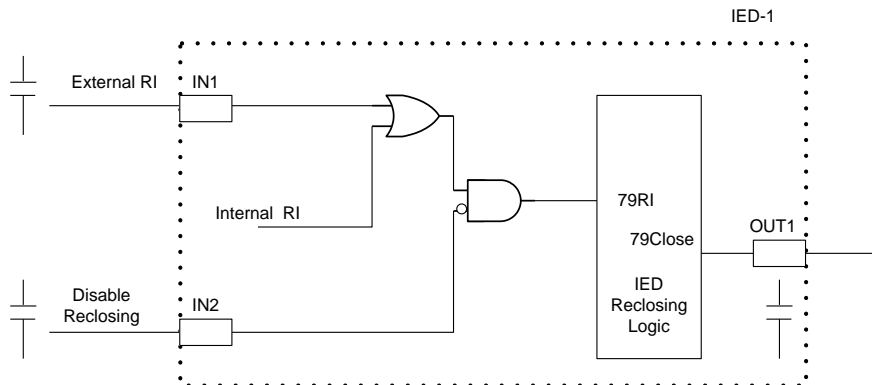

**Figure 7.2, Documentation of Internal IED Logic**

Consider the very simplistic example in Figure 7.2. In the example, the IED implements the Reclosing logic in a feeder application. The internal reclosing logic is documented as a block in the drawing and its specifics are documented in the instruction book of the IED. What is not documented in the instruction book of the IED are the inputs to the reclose cycle initiation (79R1) and that logic can be documented in a drawing as shown in figure 7.2. It is also conceivable that the IED settings be part of the internal IED logic documentation.

A DC elementary diagram relates the IED inputs and outputs to the wiring used to implement the IED functions. Figure 7.3 shows an example of an Elementary DC diagram. The physical inputs and outputs used in the different wired logic schemes in the substation are shown in this type of drawing. This type of drawing may be self-describing (as in the figure); but, in modern IEDs the inputs and outputs are fully programmable and some description may be needed to fully identify the functionality of the I/O.

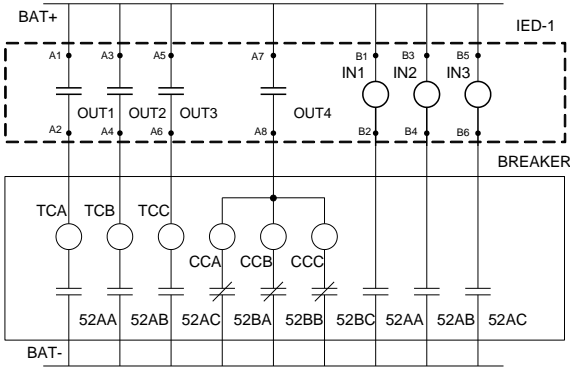

**Figure 7.3 - Elementary DC Diagram of the Breaker Status, Trip and Close Circuits of a Single Phase Trip Scheme**

87LB-CEN2 XXX-XXXX				
RELAY	TEST SWITCH SIC- 87LB-CEN2	DWG REF.	CIRCUIT	FUNCTION
OUT1	A	P1893-DC42	CB110 T2	TRIP CB110 TC2
OUT2	B	P1893-DC42	CB110 C&T1	CLOSE CB110
OUT3	C	P1893-DC43	CB120 T2	TRIP CB120 TC2
OUT4	D	P1893-DC43	CB120 C&T1	CLOSE CB120
OUT5	E	P1893-DC40	21A-CEN2	BFI/79RI LINE, 42A
OUT6	F			WIRED OUT NOT USED
OUT7		P1893-DC40	87L-CEN2	ALARM DISPLAY LIGHT
OUT8	G	P1893-DC42	CB110 T2	TRIP CB110 TC2
OUT9	H	P1893-DC43	CB120 T2	TRIP CB120 TC2
OUT10				NOT USED
OUT11				NOT USED
OUT12				NOT USED
OUT13				NOT USED
ALARM		P1893-DC03	DCP-B2	RELAY FAIL ALARM
IN1		P1893-DC42	CB110 T2	52B CB110
IN2		P1893-DC43	CB120 T2	52B CB120
IN3		P1893-DC42	CB110 T2	CB110 SYS A CONTROL VOLTAGE ALM
IN4		P1893-DC40	87LB-CEN2	CLOSE PERMISSIVE, 25B-120
IN5	I	P1893-DC40	87LB-CEN2	RELAY OUT OF SERVICE
IN6	J	P1893-DC40	87LB-CEN2	BLOCK RMB TRIP

**Figure 7.4 - Example of an I/O Cross-Reference Table**

Figure 7.4 illustrates a cross-reference table that identifies the functionality of the I/O for an IED. This table can identify I/O that is not being used in the design; which is very useful when maintaining the design and for any further modification in it.

### 7.2.3 Documentation Issues of Protection and Control Functions in different IEDs.

With multifunction IEDs in the substation, several processes can be running in an IED using the same inputs. The wiring diagrams may not describe in detail the functionality and the purpose of the internal logic in the devices. Moreover, with the powerful programmable logic available and customized programming in these devices, it is a challenge to document the functionality when several IEDs are involved.

With the use of dedicated serial communication channels to exchange logic bits and the use of protection and control commands in a substation network (GOOSE messages) to create substation functions distributed in several devices is a challenge as well.

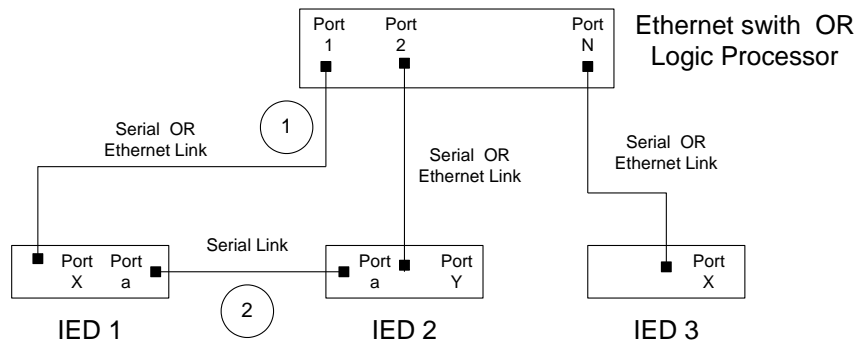

**Figure 7.5 - Documenting IED's Communication Links**

Documenting the communication may have the format shown in Figure 7.5 where the physical connections of the communication links are shown. The port numbers are clearly identified as any other wiring diagram would be. Whether it is serial communications architecture to a logic processor or an Ethernet network connection to a switch, it is important that it be documented in some fashion as shown in Figure 7.6. Serial communications for protection and control is also possible between IEDs and may also be documented as shown in Figure 7.5.

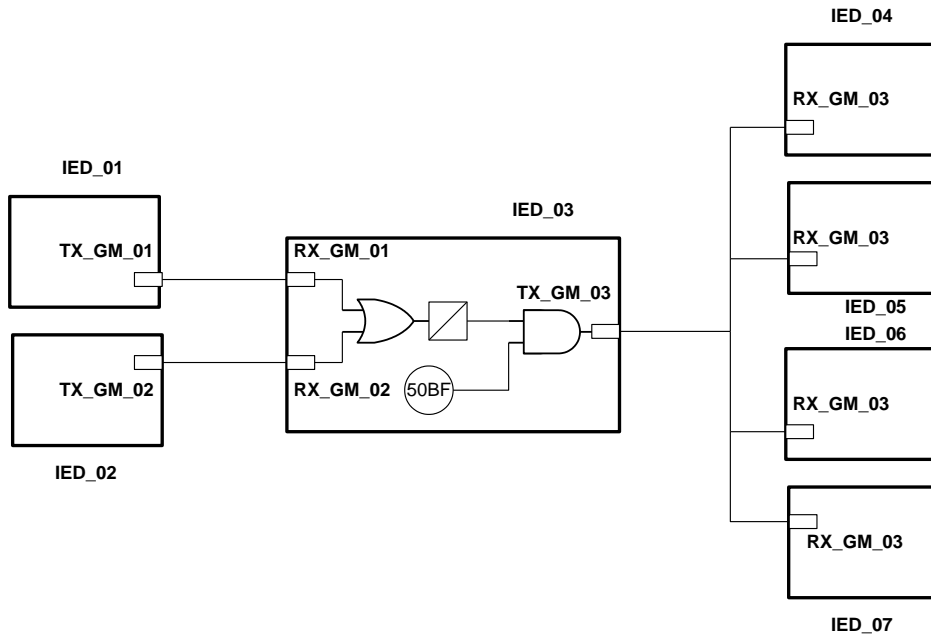
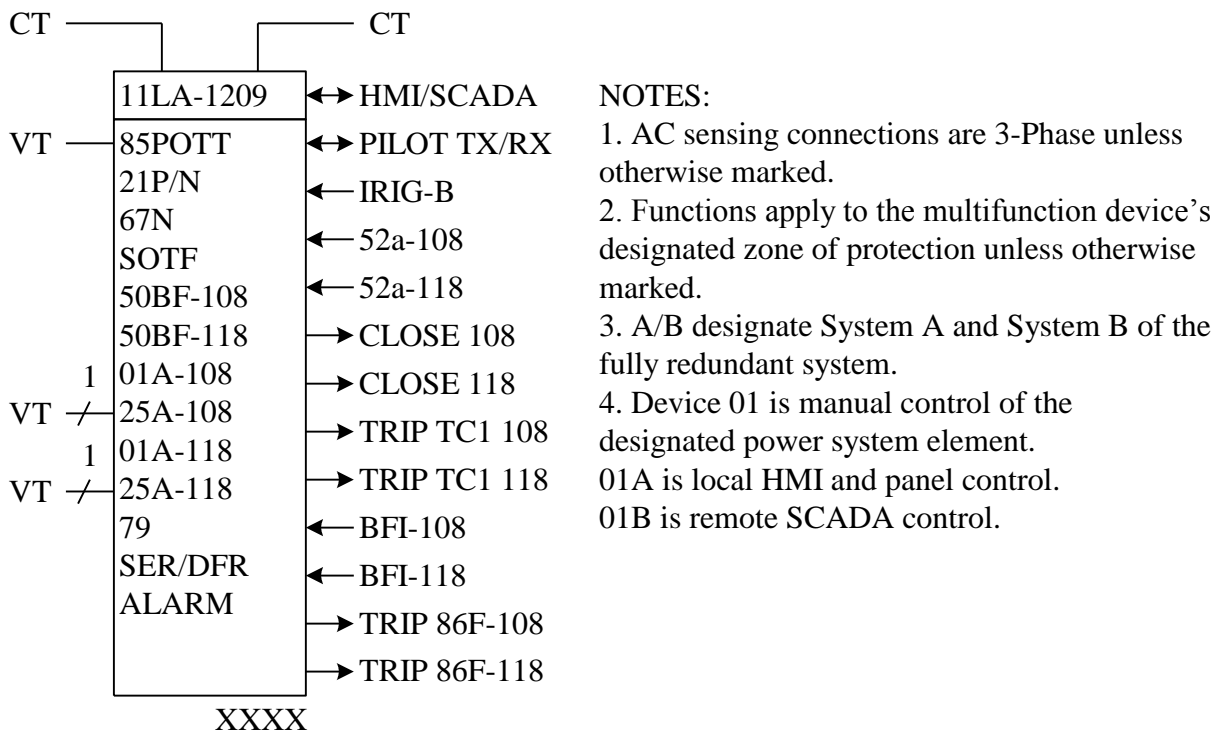

**Figure 7.6 - Documenting Serial or Ethernet Network Messages**

Logic implemented in different IEDs can be documented as shown in the simple example in Figure 7.6. In the figure, GOOSE messages (GM) are being used as examples of transmitted messages in a network. The origin of the message is shown in the figure with the 'TX' marking. The data reception is shown with the "RX" marking. The above is a simple example of a BF scheme where the primary and secondary protective relays initiate the breaker failure relay (IED\_03). The BF message (TX\_GM\_03) is then distributed to other IEDs.

### 7.2.4 List Box

The “list box” method of documenting the contents of a multifunction device 11 (from IEEE Std C37.2TM-2003 copyright IEEE 2008 used with permission) is a compromise between the empty box method, that forces the user of the diagram to go to other, more detailed, diagrams to determine what functions are provided in the protection and control system, and the filled box method that can be cumbersome and difficult to generate.[5] In the “list box” method, the functions in the multifunction device are simply listed. Figure 7.7 is an example of the “list box” method as used in a highly integrated system. The zone of protection covered by this multifunction device 11 is Line 1209. The line is connected to a breaker-and-a-half substation via bus breaker 108 and middle breaker 118. This device is the System A multifunction device for line 1209. There is also a System B multifunction device 11 on line 1209 as well, and would have its own “list box”.



**Figure 7.7 – List Box Documenting Method**

Shown are the major functions provided in this device for the protection, monitoring, and control of line 1209 and its associated breakers. It also shows how remote SCADA and local control is implemented in which devices (to maintain redundancy). Note that automatic reclosing (device 79) is implemented on a per line basis and not on a per breaker basis (otherwise it would have been listed as 79-108 and 79-118). The reclosing function is not redundant and thus does not have an A or B suffix. To maintain redundancy for the various close control functions, synch-check (device 25) is redundant (it does have an A or B suffix). The binary I/O and communications connections (arrows on the right side of the box) are optional, and may be implied (not shown) to reduce the complexity of the diagram. XXXX is a placeholder for the manufacturer's model number of this Device 11.

## 8 REFERENCES

- [1] Michael Thompson, "The Power of Modern Relays Enables Fundamental Changes in Protection and Control System Design", Texas A&M Relay Conference, 2007, Georgia Tech Protective Relaying Conference, 2007.
- [2] Paul Anderson, Bill Fleming, Tony Lee, and Ed Schweitzer III, "Reliability Analysis of Transmission Protection Using Fault Tree Methods", Western Protective Relay Conference, 24<sup>th</sup> Annual, 1997.
- [3] Robert Brantley, Kevin Donahoe, Jacobus Theron, and Eric Udren, "The Application of IEC 61850 to Replace Auxiliary Devices Including Lockout Relays", Georgia Tech Protective Relaying Conference, 60<sup>th</sup> Annual, 2006.
- [4] Mozina, Charles (Chair) & Young, Michael (Vice Chair), "Multifunction Digital Relay Commissioning and Maintenance Testing An IEEE/IAS Working Group Report" IEEE Industry Applications Magazine, September/October 2005, pp. 50 – 58.
- [5] IEEE Std C37.2<sup>TM</sup>-2008 Standard for Electrical Power Device Function Numbers, Acronyms, and Contact Designations.
- [6] IEEE Std C37.104-2002 Guide for Automatic Reclosing of Line Circuit Breakers for AC Distribution and Transmission Lines.
- [7] IEC 61850 Communication Networks and Systems in Substations.
- [8] IEEE Std C37.119-2005 Guide for Breaker Failure Protection of Power Circuit Breakers
- [9] IEEE Std C37.234-2009 Guide for Protective Relay Applications to Power System Buses

## ANNEX 1: Example of Breaker Failure/Reclosing Functions in One Relay

This application example illustrates the use of a single digital relay to perform breaker failure and reclosing functions for a single SF6 type 115kV breaker. The application includes the following ancillary features and advantages:

1. Incorporation of 25 (synchronizing), 27 (undervoltage), 79 (reclosing), 50 (fault detector) and 62BF (breaker failure timer) functions in one relay. The relay is also used for remote closing via SCADA and line sectionalizing if needed.
2. Local manual closes bypass the relay entirely and use a sync-scope and voltmeters.
3. Breaker trips are not processed by relay, but manual trips will prevent the breaker from reclosing (drives the relay to lockout).
4. Reclose initiation is mostly by breaker position; line relay trips and transfer trips can also be used to initiate reclosing as well as breaker failure.
5. Both recoverable (temporary) and non-recoverable (permanent faults) events will stall relay from reclosing.
6. Additionally, non-recoverable trips such as a bus fault will lockout the relay from reclosing via reclose supervision.
7. Breaker failure initiates (BFI's) into the relay are split up into high current (HC) and low current (LC) inputs. High current faults typically involve lines and busses while low currents can be associated with transformer faults or the receipt of transfer trip. Breaker failure supervision for the high current faults is provided by fault current detectors alone; low current faults are supervised by breaker position as well as fault current detectors.
8. Tripping for breaker failure is typically done via hand-reset lockout relays.
9. For newer SF6 gas breakers, the breaker failure timer is bypassed for low-low (lockout) gas pressure.

Shown below is a representative list of inputs and outputs used on the relay. These inputs and outputs are also shown on the attached schematic drawings.

### Digital Inputs

Input	Function	Notes
IN1	Stall Logic	Stalls reclosing until transformer MOD opens or transfer trip input drops out
IN2	Close Supervision Logic	Bus lockouts & breaker failure lockouts
IN3	Reclose Initiate	52b breaker auxiliary contact or Reclose Initiate Trips from line relays

		or transfer trip receivers
IN4	269R/43R	SCADA reclosing permissive and lead/lag selection (as required)
IN5	SCADA Close	201 close contact via SCADA
IN6	Drive to Lockout – DTL	Manual/SCADA trips and reclosing cutoff switch inputs
IN7	BFI (High Current)	21P, 21B, 87 (line or bus relays)
IN8	BFI (Low Current)	86P/1X, 94TT/L1 (transformer or transfer trips)
IN9	52A	52a breaker auxiliary contact
IN10	BKR Low-Low Gas Pressure (63X)	Breaker Lockout (PRI & BU Trip Coils)

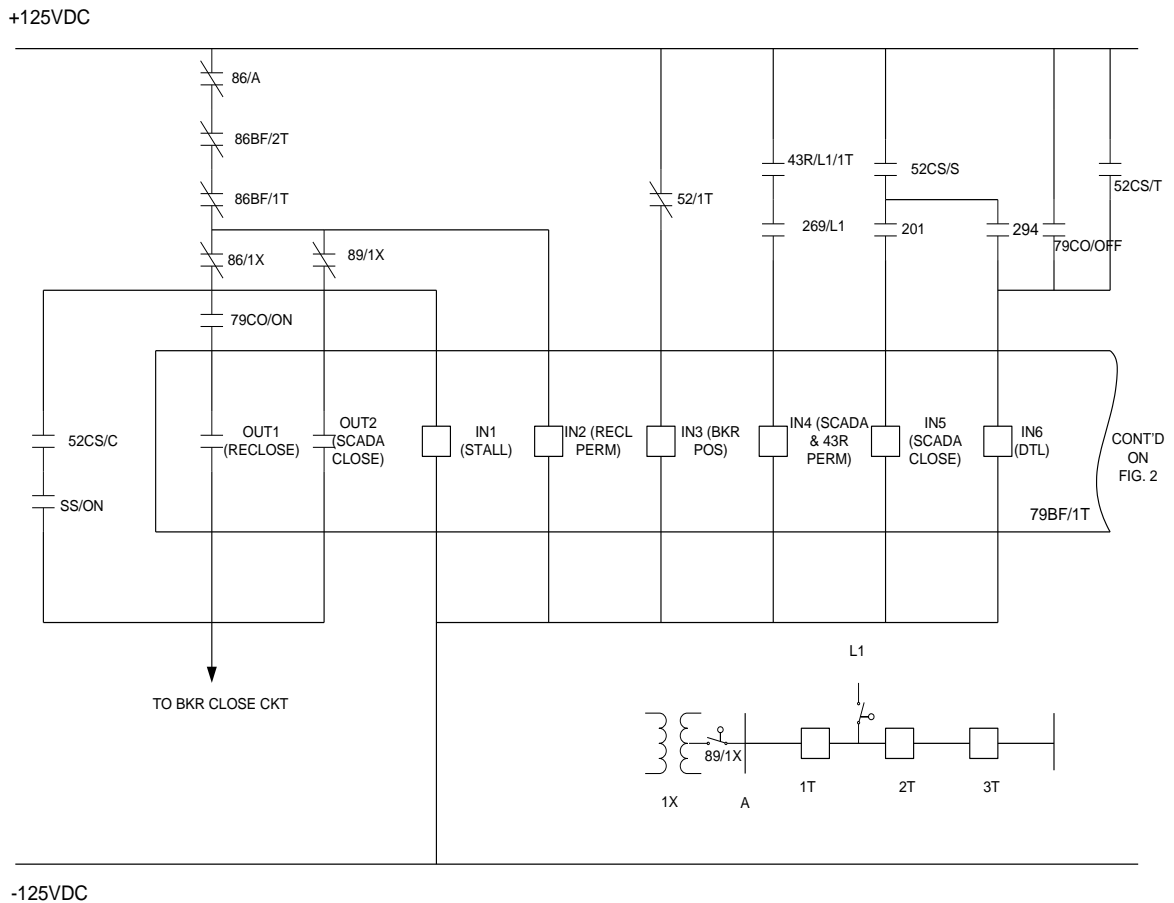

Figure A 1.0 - Close/reclose Circuit for 1T Breaker

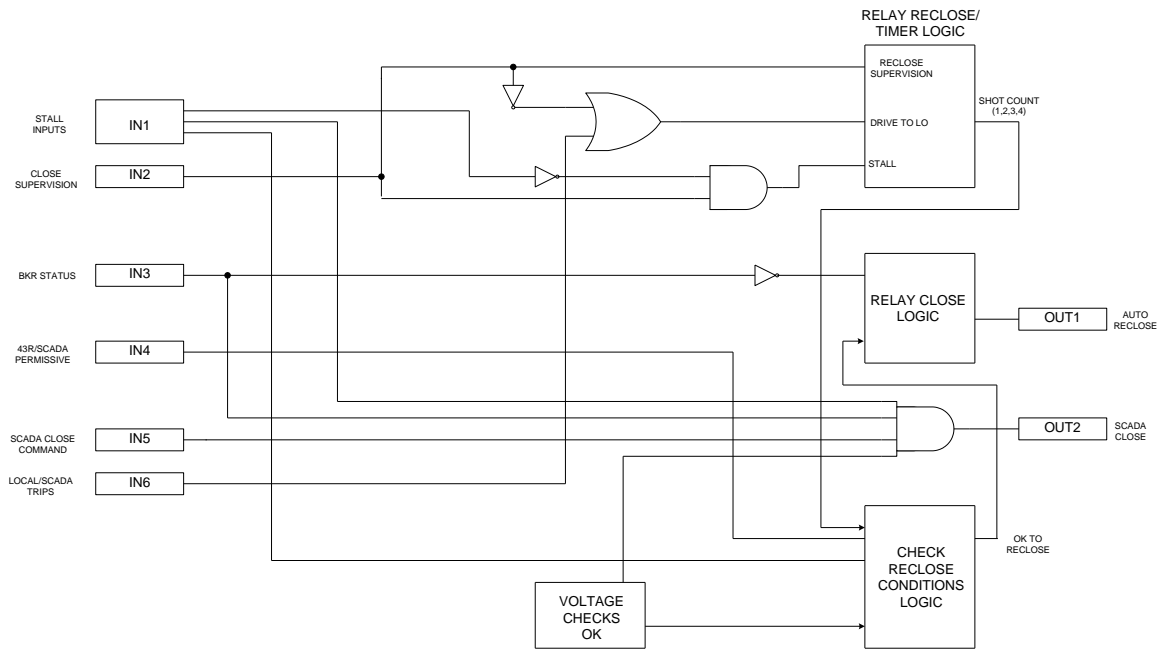

Figure A 1.1 - Close/reclose Logic for 1T Breaker

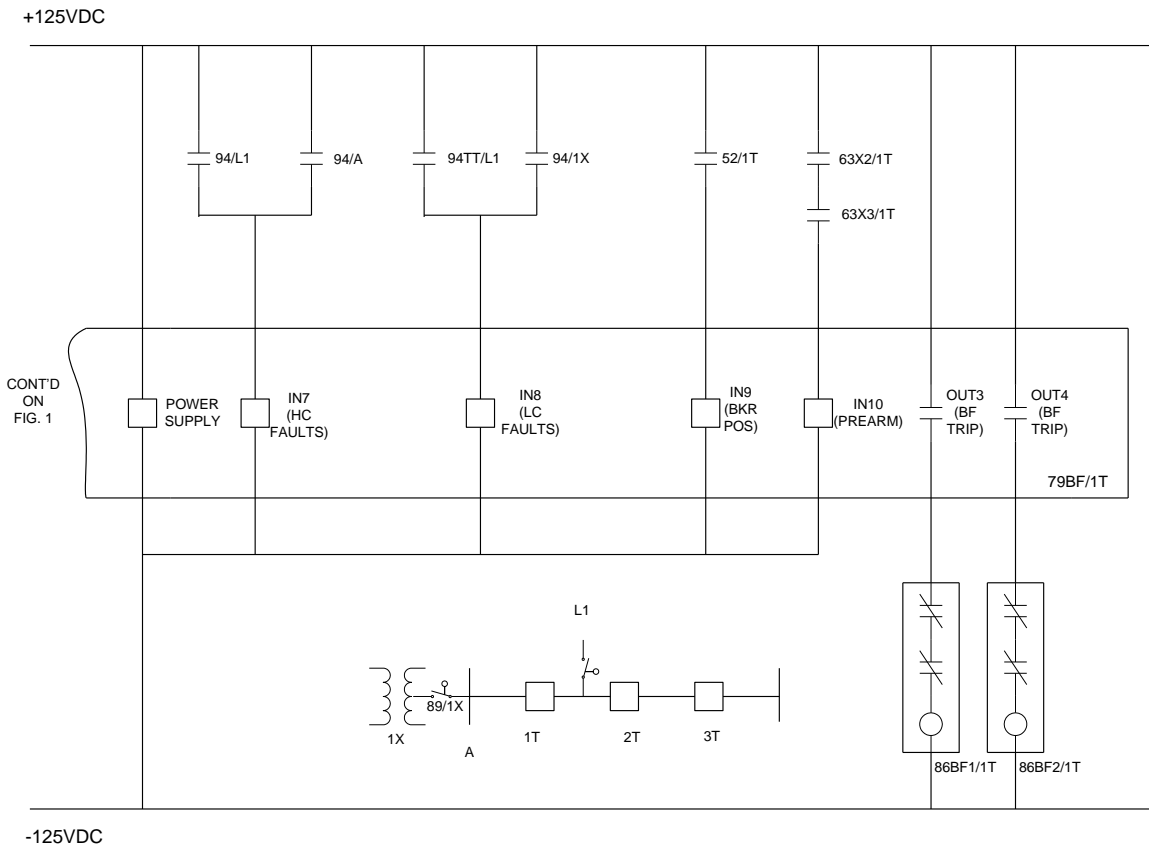

Figure A 1.2 - Breaker Failure for 1T Breaker

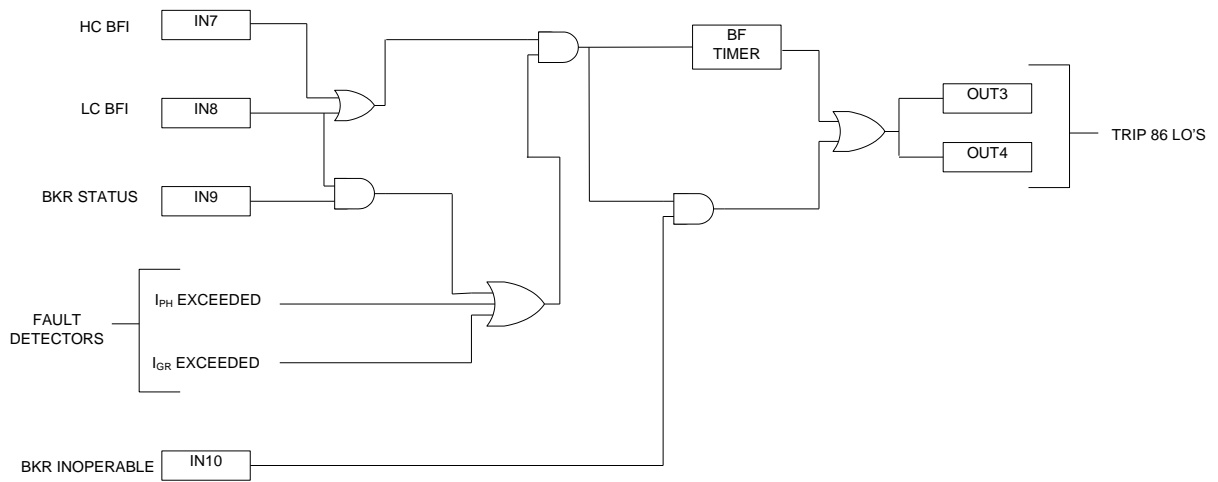

Figure A 1.3 - Breaker Failure Logic for 1T Breaker

## ANNEX 2: Example for an Automatic Transfer Scheme

The 100/44 kV Substation shown in Figure A 2.0 can be supplied from either Source A or Source B, but typically not from both sources at the same time. Since this particular station is supplied radially from the 100 kV system, non-directional overcurrent protection was applied to the 100 kV source breakers and coordinated with the overcurrent relays protecting the transformers and the transformer high-side breaker. An automatic transfer scheme was implemented using several voltage and logic elements in the relay such that if the “normal” source of supply is lost, the station can automatically transfer to the “alternate” source. Some “breaker preference” logic was also implemented to tell the automatic transfer scheme which source is “normal” and to permit automatic reclosing of the correct breaker after a trip by an overcurrent relay element. In the days of individual component relays, the auxiliary relays and timers required for the automatic transfer scheme and the “breaker preference” selector switches were mounted on the same relay panel as the source breaker overcurrent protection. Therefore the new overcurrent relay for the source breakers became a natural place in which to implement the new automatic transfer and “breaker preference” logic. For this particular protection scheme, a secondary or back-up overcurrent relay was not provided. When a back-up relay is provided, it can either be a relay whose capabilities are equivalent to the primary relay or it can be a relay with equivalent overcurrent protection capabilities but without the logic and programming capability of the primary relay. If the primary and secondary relays are equivalent, the user elects either to provide automatic transfer, reclosing, and breaker preference logic in the secondary relay but enable it only if the primary relay fails, or the user elects to provide only overcurrent protection in the secondary relay. The latter case is equivalent to installing a secondary relay with overcurrent protection capability only.

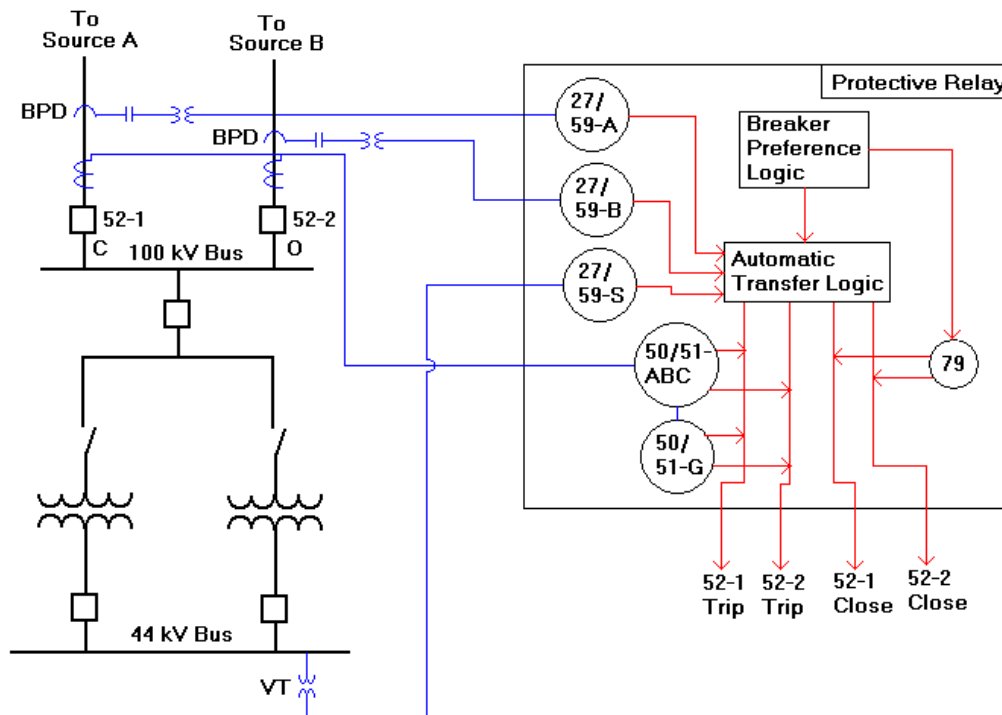

Figure A 2.0 – One Line Diagram

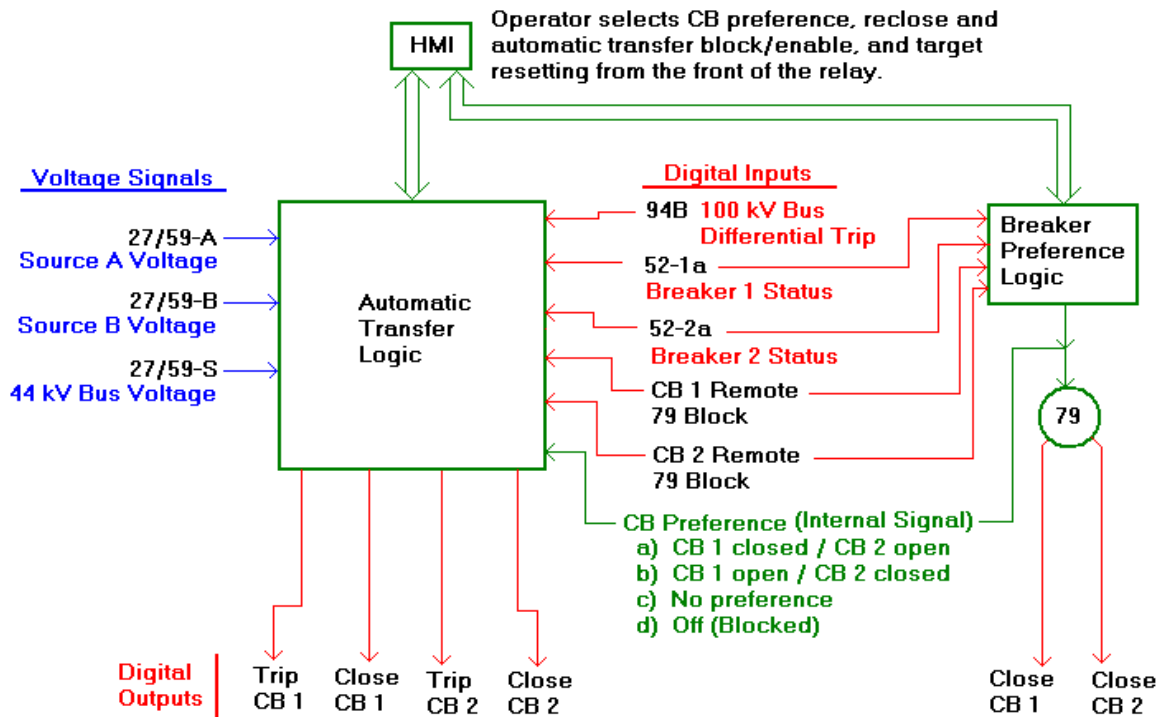

Figure A 2.1 – Logic Diagram

Figure A 2.1 shows the relay elements and the I/O required to implement the automatic transfer and “breaker preference” logic in the relay. The station operator selects which operating configuration is preferred through the human-machine interface (HMI) on the front of the relay. The operator can also selectively trip and close breakers and block automatic reclosing from the HMI. If CB Preference (a) has been selected, and the Source A voltage is lost, the 27A will signal the undervoltage condition to the transfer logic. The 27S will also signal loss of the 44 kV Bus voltage to the transfer logic as verification that Source A is really dead. If Source B voltage is present, the 59B will provide that information to the transfer logic. If Source A is dead and Source B is hot for more than 3 seconds, the automatic transfer logic will trip the Source A breaker. After the Source A breaker is open, the transfer logic will automatically close the Source B breaker to restore service to the station. If the Source A voltage is later restored and the transfer logic sees that both Source A and Source B have both been hot for more than 60 seconds, the transfer logic will close the Source A breaker. After the Source A breaker is closed, the transfer logic will then trip the Source B breaker to return to the original “preferred” operating configuration.

When the CB Preference is (b), the station will be transferred to Source A if Source B goes dead, and it will transfer back to Source B after Source B is restored. When the CB Preference is (c), a transfer will be made from the dead source to the hot source in 3 seconds, but there will be no “return” transfer in 60 seconds if the dead source later becomes hot. When the CB Preference is (d), the automatic transfer logic is blocked from operating.

The “breaker preference” logic also controls which breaker the 79 will actually close after an overcurrent trip. For example, if the CB Preference is (a) and an overcurrent element trips Breaker A and initiates the 79, the 79 will know to close Breaker A and not Breaker B. When the CB Preference is (c) or (d), the logic remembers which breaker was initially closed so that the 79 will reclose it after an overcurrent trip.

The automatic transfer logic is automatically blocked for a bus differential operation and for remote (as well as local) blocking of the 79.

Here are the relay elements and I/O required to implement the automatic transfer and “breaker preference” logic in the relay. The station operator selects which operating configuration is preferred through the human-machine interface (HMI) on the front of the relay. The operator can also selectively trip and close breakers and block automatic reclosing from the HMI. If CB Preference (a) has been selected, and the Source A voltage is lost, the 27A will signal the undervoltage condition to the transfer logic. The 27S will also signal loss of the 44 kV Bus voltage to the transfer logic as verification that Source A is really dead. If Source B voltage is present, the 59B will provide that information to the transfer logic. If Source A is dead and Source B is hot for more than 3 seconds, the automatic transfer logic will trip the Source A breaker. After the Source A breaker is open, the transfer logic will automatically close the Source B breaker to restore service to the station. If the Source A voltage is later restored and the transfer logic sees that both Source A and Source B have both been hot for more than 60 seconds, the transfer logic will close the Source A breaker. After the Source A breaker is closed, the transfer logic will then trip the Source B breaker to return to the original “preferred” operating configuration.

When the CB Preference is (b), the station will be transferred to Source A if Source B goes dead, and it will transfer back to Source B after Source B is restored. When the CB Preference is (c), a transfer will be made from the dead source to the hot source in 3 seconds, but there will be no “return” transfer in 60 seconds if the dead source later becomes hot. When the CB Preference is (d), the automatic transfer logic is blocked from operating.

The “breaker preference” logic also controls which breaker the 79 will actually close after an overcurrent trip. For example, if the CB Preference is (a) and an overcurrent element trips Breaker A and initiates the 79, the 79 will know to close Breaker A and not Breaker B. When the CB Preference is (c) or (d), the logic remembers which breaker was initially closed so that the 79 will reclose it after an overcurrent trip.

The automatic transfer logic is automatically blocked for a bus differential operation and for remote (as well as local) blocking of the 79.

### ANNEX 3: Example of a Shunt Capacitor Protection Scheme

Figure A 3.0 shows an overcurrent protection scheme for two sets of 100 kV ungrounded wye capacitors. Relays 1 and 2 provide redundant phase and ground overcurrent protection for both capacitors. Relay 1 provides Capacitor 1 neutral overcurrent (“blown can fuse”) protection and Relay 2 provides Capacitor 2 neutral overcurrent protection. Both relays are microprocessor-based, but Relay 1 has the additional programming logic capability required to implement the capacitor control scheme. The capacitor controller brings Capacitor 1 on-line first. If the bus voltage is still low, it will then close the circuit switch (CS) to energize Capacitor 2. Similarly, if the bus voltage becomes too high, the controller will switch out Capacitor 2 first, followed by Capacitor 1, if the high voltage condition persists.

Lockouts 86C, 86BF, 86CN-1, and 86CN-2 were also implemented as logic inside Relay 1 instead of using a conventional “hand-reset” lockout relay mounted on the relay panel. The lockouts in Relay 1 can be reset by the station operator via the HMI on the front of the relay. The control switches for opening and closing the breaker (CB) and circuit switch were also implemented as logic inside Relay 1. The relays also provide alarms for blown can fuses via a 74CN relay (not shown) located in the same current circuit as the 51CN-1 and 51CN-2, respectively.

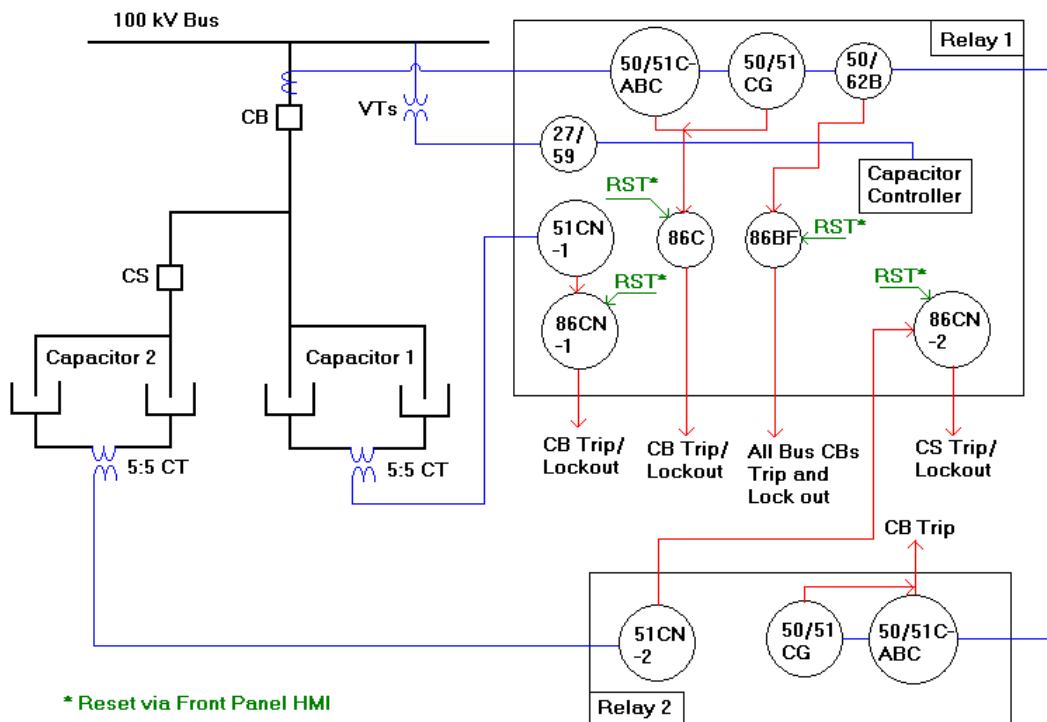

Figure A 3.0 – Logic Diagram

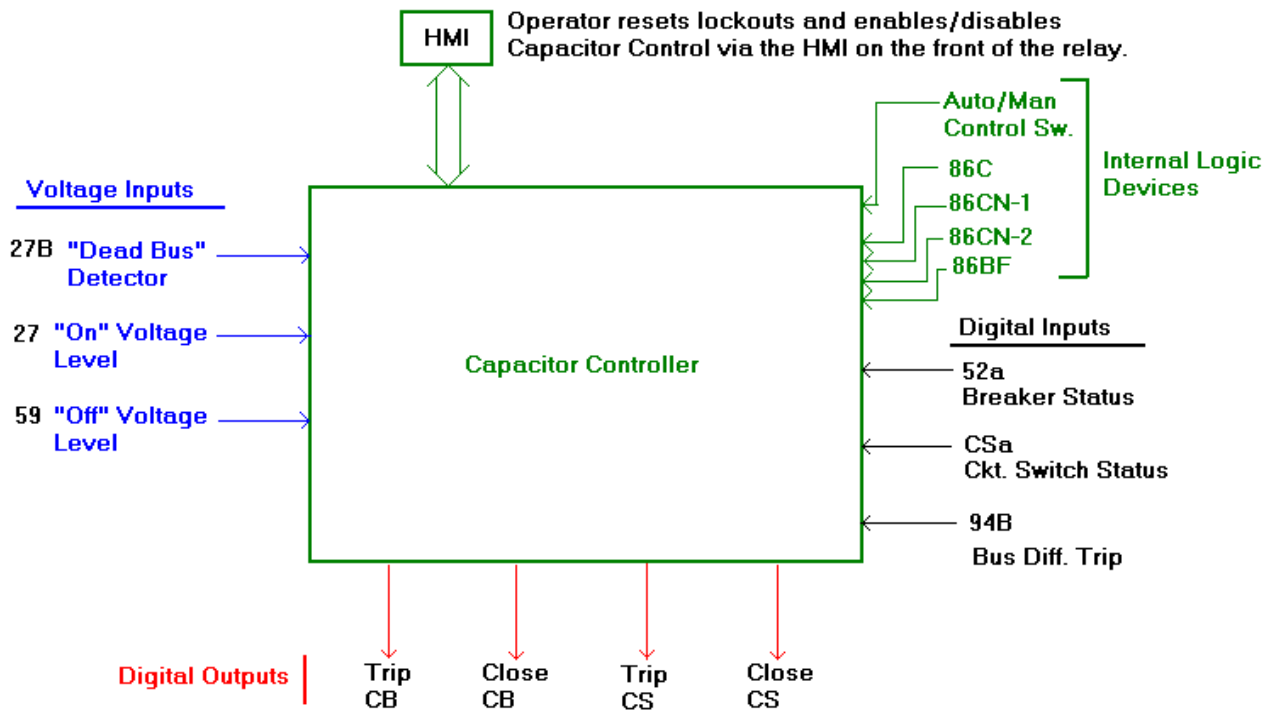

Figure A 3.1 – Logic Diagram

#### ANNEX 4: Example of Transformer Trip and Isolation Logic

Figure A 4.0 shows a transformer protection scheme for each transformer of a two-transformer distribution substation. The motor-operated disconnects (MODs) 89-1 and 89-2 are for isolation purposes only. High-side fault clearing for a transformer fault is provided by Breaker 52-1. In the days of individual component relays a transformer trip and isolation scheme was provided to automatically isolate a faulted transformer from the system and allow Breaker 52-1 to be automatically reclosed to restore the unfaulted transformer to service. Since the relay containing the transformer differential function initiates tripping of both 52-1 and 52-4 (or 52-2), it made sense to the engineer to implement the transformer trip and isolation logic inside the transformer differential relay, which in this scheme is considered to be the primary relay. The transformer trip and isolation logic for Transformer Tx-2 is initiated by any of the protective relay functions in the primary relay. The logic also monitors the status of “a” contacts from Breakers 52-1, 52-4, and MOD 89-2.

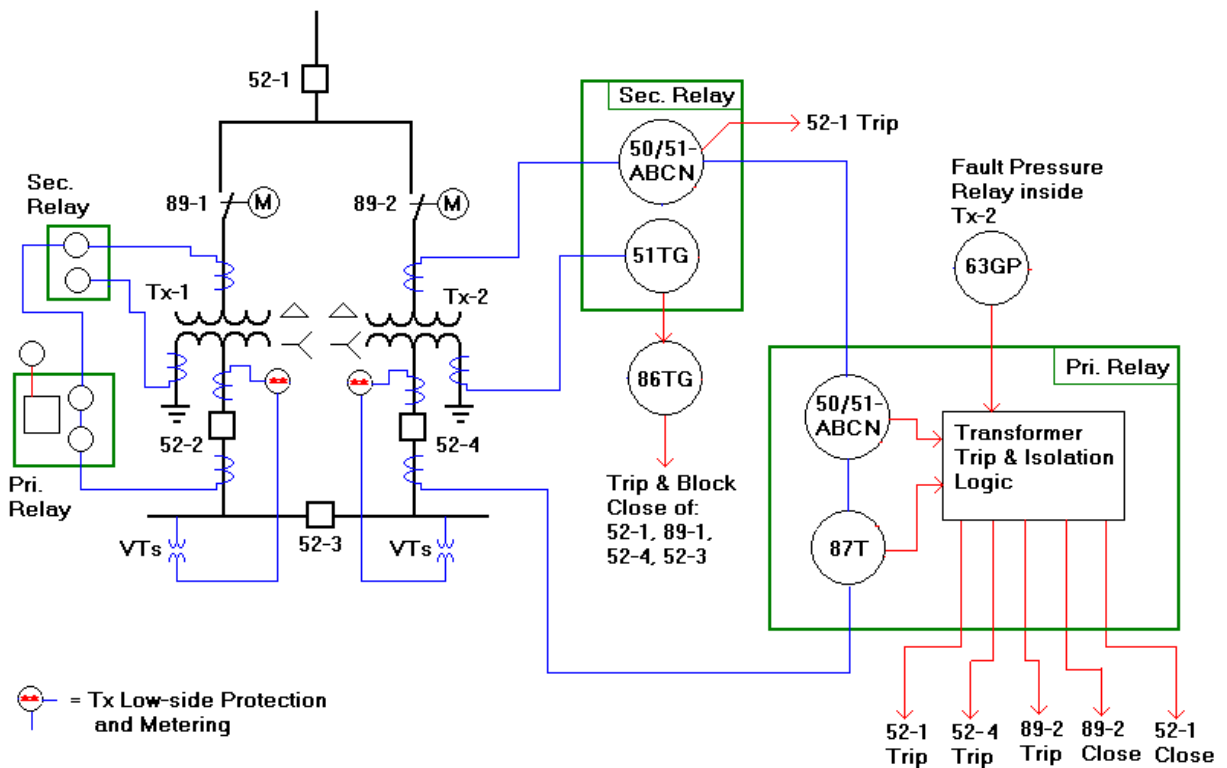

Figure A 4.0 – One Line Diagram

When the transformer trip and isolation logic is initiated, the following sequence of events happens:

1. The logic trips Breakers 52-1 and 52-4.
2. When Breaker 52-1 is open, the logic opens MOD 89-2.

3. Approximately 15 seconds after MOD 89-2 is open, the logic closes Breaker 52-1 to re-energize Transformer Tx-1.

The same sequence of events will happen with Breakers 52-1, 52-2, and MOD 89-1 for a Transformer Tx-1 fault.

The operator also has the capability of tripping or closing Breakers 52-1, 52-4, or MOD 89-2 via the HMI on the front of the relay. The relay was also programmed to display a "63GP Trip" target on the relay display for a 63GP operation. Display target resetting via the HMI was also programmed in the relay logic.

Note that in this particular transformer protection scheme the secondary relay does not have the same programming capability as the primary relay. Therefore, if the primary relay fails or is removed from service, the unfaulted transformer cannot automatically be restored to service, and the only transformer protection is provided by the overcurrent elements in the secondary relay. There is also no redundancy for transformer neutral protection relay 51TG.

ANNEX 5: Example of an Analysis of the Allocation of Breaker Failure Functions in Line Relays

The following is a utility's analysis on how to allocate the breaker failure functions in the line relays for the middle breaker in a breaker and a half bus arrangement. Each of the line relays being used have the capability of providing the breaker failure function for two breakers. Figure A 5.0 is the current circuit one line diagram of each of the line relays. With two line relays being applied per line and with each line relays having breaker failure relay functions, the middle breaker in Figure A 5.1 could have up to four breaker failure relays.

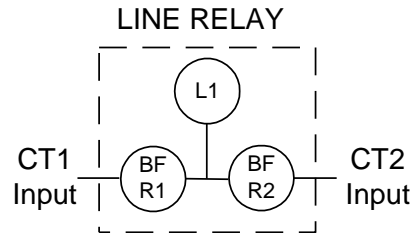

L1 - Line Relay Functions  
 BF R# - Breaker Failure Relay Functions

Figure A 5.0 - One Line Diagram for Line Relays

In the first case (Figure A 5.1), the breakers are live tank breakers with free standing current transformers installed on only one side of each breaker. Two line relay systems (P & S) are applied for each line and each of the line relay systems contain breaker failure functions which can be used for the middle breaker (M).

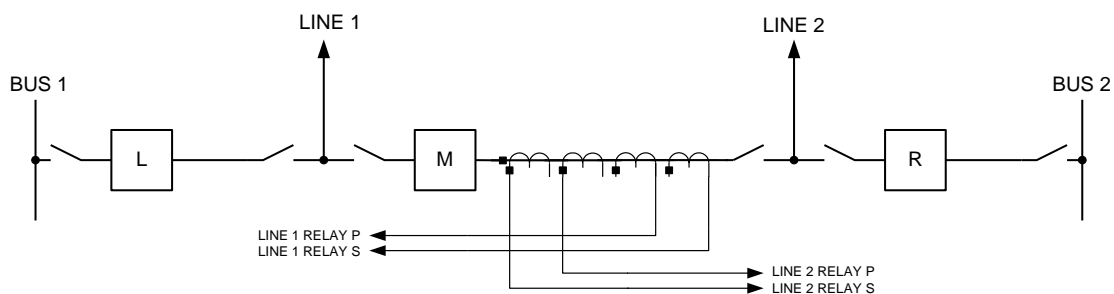

Figure A 5.1 - One Line Diagram with Live Tank Breakers

Use of four breaker failure functions:

Pros - each line protection has the same look and feel (settings, application)

- if one line relay is out of service there will still be a breaker failure relay in service for the breaker
- Cons - decreases security
- four BF protections to test
- extra wiring between the line relays if cross initiation is used (refer to section 3.2.4 (Figure 3.0 c,d)
- more relay settings to change if there is an issue with the settings

Use of 2 breaker failure functions (both relay systems for one line):

- Pros - meets the application requirement without providing additional unnecessary functions
- no extra wiring
- Cons - line protections not the same
- may be dependability hole if line protection is out of service
- the adequacy of the protection of the stub section between the CTs and the breaker will depend on which line relay's breaker failure functions are used

#### Synopsis

Though it is desirable that the line protection have the same look and feel, application of four breaker failure functions is unnecessary.

With respect to protection of the short bus section between the CTs and the breaker, it does not matter which CTs the breaker failure function are located in, all CTs see the same current.

Being consistent with the utility's past practice, if only one line's relays are utilized for the breaker failure function it will be in the relays that zone of protection includes the breaker. That is why the Line 1 relays would be used in this case – refer to section 3.2.4 (Figure 3.0 e).

In the situation where Line 1 relay's P and S are out of service, then there is no concern because the line would be out of service at that time and the middle breaker would be open with the disconnected switches open.

For the case where the L and M breakers are open but the disconnect switches are not open and a fault occurs between the M breaker and the CTs, the breaker failure functions would be disabled if the Line 1 relays are disabled. But in this case the fault detection relays are disabled so having the breaker failure function in-service would not be a benefit. The best scenario for this case is that the line relays would not be taken out of service before the breaker isolator switches are opened.

In case two, a dead tank breaker, identified as CB2 in Figure A 5.2 is used with current transformers on all bushings. For this case, it is arbitrary which line protection is used since both line relays include the breaker in its protection zone. Nevertheless, for consistency reasons only, a rule can be developed. The circuit with the lower circuit number will be used to provide the breaker failure function for the common breaker.

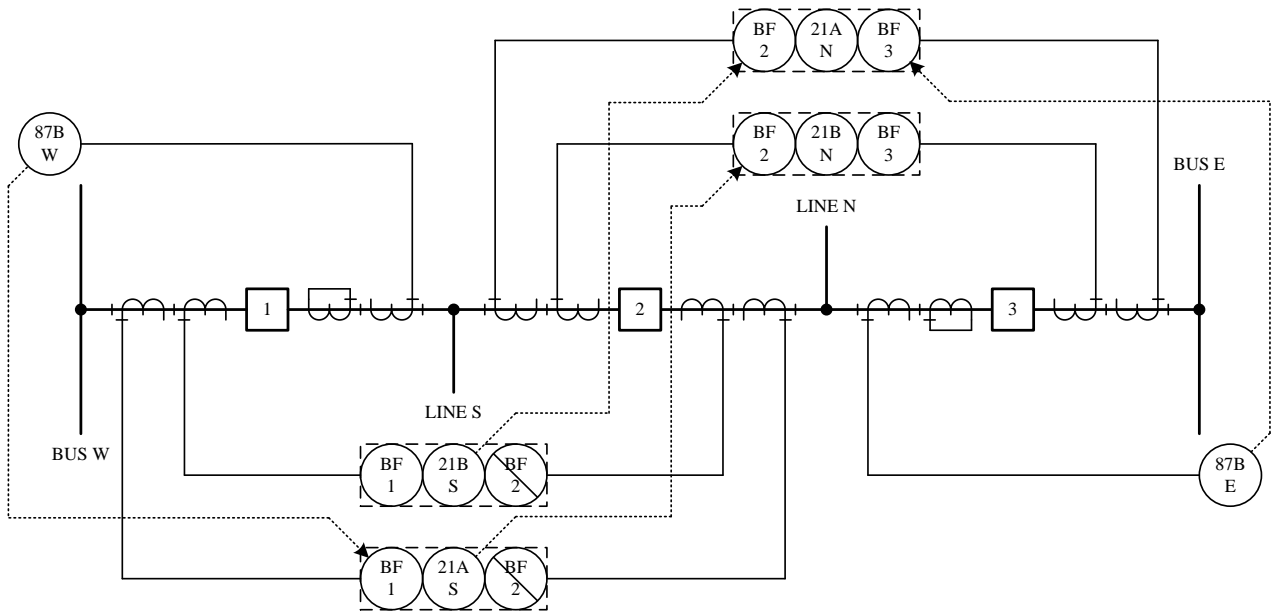

Figure A 5.2 - One Line Diagram with Dead Tank Breakers

As illustrated in Figure A 5.2 line protection 'N' utilizes its breaker failure functions to provide breaker failure protection for CB2 ie: line N has a lower alpha numeric designation than line S.

In conclusion the following guidelines are proposed for breaker failure application function allocations in line protection relays:

1. For middle breakers that are live tank breakers with only one free standing current transformer utilize the breaker failure functions of the line's protection which includes the breaker in its protective zone.
2. For middle breakers that are dead tank breakers with current transformers on all bushings the circuit with the lower line number will utilize the breaker failure functions in its line protection. This covers the case of both line's protection being replaced at the same time.
3. For when the replacement of the line relays are not replaced in the same project, the breaker failure function will be enabled in the first line's protection that is replaced.

## ANNEX 6: Example of Using Two Multifunction Line Relays on a Single Breaker

A southeast United State electric utility company developed a transmission line protection panel design utilizing two microprocessor-based multifunction relays. Auxiliary functions in the relays are for the most part related to the line's associated single-bus single-breaker connected circuit breaker.

One relay is labeled "primary". The other relay is labeled "secondary". Both primary and secondary relay have the same auxiliary protection functions available:

- Breaker Failure (for only one breaker)

- Automatic Reclosing including:

  - Synchronism Check Supervision

  - Undervoltage Line / Healthy Voltage Bus Supervision

  - Timers

The design utilized the breaker failure functions in both relays. The breaker failure functions were cross triggered so that the fault detecting elements in each relay would initiate the breaker failure function in both relays. The operation of the breaker failure function is either relay operated a common lockout relay.

The automatic reclosing functions in only the primary relay were utilized. The secondary relay has no breaker close capability.

This design is shown in Figure A 6.0.

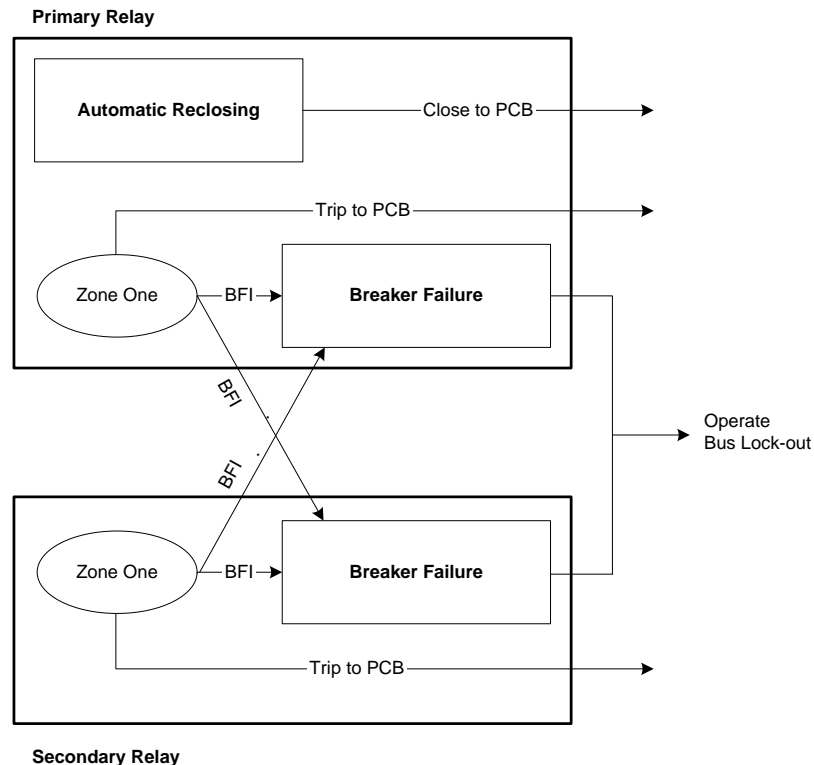

Figure A 6.0 - Logic Diagram