

The Perfect Time: An Examination of Time Synchronization Techniques

Ken Behrendt and Ken Fodero, *Schweitzer Engineering Laboratories*

I. INTRODUCTION

A combination of circumstances has made this the perfect time to look at time synchronization techniques for power system monitoring devices:

- Time synchronization of power system monitoring devices is now center stage because of the problems experienced with post-disturbance analysis following the August 14, 2003 blackout in the northeastern United States and southeastern Canada. NERC recommendations, based on the lessons learned from this post-disturbance analysis, place a high priority on implementing time synchronization techniques that will eliminate or reduce the effort involved with comparing event information from distributed intelligent disturbance recording devices.
- Maturing synchrophasor measurement technology is also creating a demand for very accurate time synchronization of devices in widely separated locations.
- Global Positioning System (GPS) high-accuracy synchronized time code signals are now accessible through economical clock receivers that are designed for simple and reliable installation in the harsh environment of electric power facilities.
- Time synchronization can be accomplished through communications network technologies that are becoming more prevalent in utility and industrial power facilities.

This paper discusses available techniques to acquire synchronized time signals, various standard time signal formats, techniques for distributing these time signals to monitoring and recording devices, and the relative accuracy required by various power system timing and recording applications. Emphasis is given to the accuracy requirements of monitoring and recording devices, the relative accuracy of time signal sources, the effect that time signal distribution has on the accuracy of the signal, and the effect that device sampling and processing have on the accuracy of time tags applied to sampled data.

Time synchronization signal sources include earth-based radio transmission (WWV, WWVH, WWVB, and LORAN-C), satellite-based signal transmission (GOES, GPS, and GLONASS), and time-setting messages via communications networks and dial-up modems. All of these time synchronization signal and time-setting sources can usually be traced back to common or coordinated precision time references operated and provided by government standards organizations.

Coordinated Universal Time (UTC) has become the de-facto standard time reference for many applications, including most electric power industry applications. This time is now the accepted standard because of its worldwide availability and relatively economical access through GPS satellite clock receivers. This paper focuses on the use of GPS satellites as a synchronized time source and compares and discusses various clocks and clock signal distribution methods to meet electric power industry time synchronization applications. The other time synchronization sources mentioned above are discussed in the appendix of this paper for reference purposes.

II. ABOUT TIME [1]

Ancient civilizations measured the passage of time by the relative motion of the Sun, Moon, planets, and stars. From their repetitive motion, our ancestors determined seasons, months, and years.



Fig. 1. Relative Motion of Sun and Stars Provided Means of Measuring Time (Picture Courtesy of NIST)

Several thousands of years ago, early civilizations developed calendars that divided the year into months, divided the day into periods roughly corresponding to our hours, and divided these periods into parts that formed the basis for our minutes. More recently, in terms of human history, people found the need to more accurately know the time of day. As far back as 5,000 to 6,000 years ago, there is evidence that the great civilizations in the Middle East and North Africa began to make clocks to satisfy their need to organize their time and schedule activities.

A. Early Clocks

The Egyptians are credited with being one of the first civilizations to formally divide their day into parts something like our hours. Obelisks were built as early as 3500 BC to provide this early time measurement. The moving shadow cast by the

obelisk under the bright sun created a form of sundial. Partitioning the day into morning and afternoon, and then later into smaller partitions, provided people with the first sense of time measurement. Nighttime hours were measured by the *merkheth*, the oldest known astronomical tool, which was another Egyptian development from around 600 BC. A pair of merkheths was used to establish a north-south line (or meridian) by aligning them with the Pole Star and measuring time based on when certain stars crossed the meridian. These early clocks and associated calendars were all based on the synchronous motion of the earth.

B. Modern Clocks

All clocks must have a regular, constant, repetitive action to create equal increments of time and a means of keeping track of these increments to display results as time advances. For many years, the earth's rotation, and its orbiting motion around the Sun, provided this constant, repetitive motion by which early clocks were synchronized. Modern clocks use a balance wheel, pendulum, vibrating crystal, or electromagnetic waves associated with the internal workings of atoms, to create the equal increments of time.

C. Quartz Clocks

Developed in the 1920s, quartz crystal oscillators eventually improved timekeeping performance far beyond that achieved using pendulum and balance wheel escapements. Quartz crystals are better because they have no gears or escapements to disturb their regular frequency. However, they still generate a frequency through a mechanical oscillation that depends critically on the crystal's size, shape, and temperature. Modern production techniques have refined the process of producing nearly identical crystals. However, no two crystals are precisely the same and, therefore, cannot have exactly the same frequency. Temperature is the other major factor affecting the long-term stability of the crystal oscillation. If temperature can be maintained within tight tolerances, then the crystal's frequency can provide stable timekeeping. If the temperature varies widely, then the quartz clock output will drift with time, relative to a standard reference. Even though they are not perfect, quartz clocks dominate the market, finding uses in virtually every commercial device that has a clock display, internal clock, or clock/calendar. But for truly precise timekeeping requirements, quartz clocks have been surpassed by atomic clocks.

D. The Atomic Age

Atoms and molecules have unique characteristic resonances, absorbing and emitting electromagnetic radiation at a stable frequency. Scientists contend that an atom or molecule here on earth resonates now at the same frequency as that same atom or molecule that existed many years ago. Atoms, in particular, have shown a remarkable consistency, throughout space and time, with a reproducible rate that forms the basis for more accurate clocks.

Experiments with radar and other extremely high-frequency radio communications in the 1930s and 1940s made possible the generation of microwave energy, needed to inter-

act with atoms. Early research focused on microwave resonances in the ammonia molecule. But attention quickly focused on a more promising technique that used atomic-beam devices and was based on the cesium atom (Fig. 2).

The cesium atom's natural frequency was formally recognized as the new international unit of time in 1967. The second is now defined as exactly 9,192,631,770 oscillations or cycles of the cesium atom's resonant frequency, replacing the old second that was defined in terms of the Earth's motions. In fact, this new standard is so precise that scientists quickly determined that the Earth's motions are not as constant and repeatable as once thought. Therefore, adjustments are now made to the time we associate with the Earth's motion, such as the length of a year.

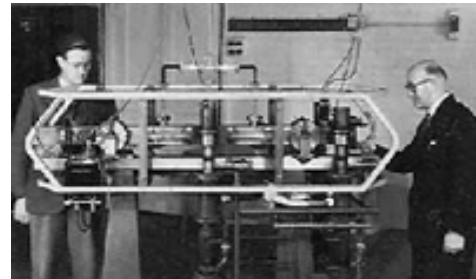

Fig. 2. First Cesium Atomic Clock, Circa 1955 (Picture Courtesy of NIST)

1) Atomic Time Scales

Temps Atomique International (TAI) is an extremely accurate time scale based on a weighted time average of nearly 200 cesium atomic clocks in over 50 national laboratories worldwide. TAI is "science" time, useful for making measurements in relativity experiments. The Bureau International des Poids et Mesures (BIPM) near Paris, France started with TAI equivalent to Earth-based time (UT1) on January 1, 1958. Coordinated Universal Time (UTC) is an atomic time derived from TAI time, with adjustments to keep it aligned with UT1.

UTC is kept within 0.9 s of UT1 by occasionally adding one-second steps called leap seconds. This adjustment maintains agreement between the atomic and astronomical time scales. The decision to introduce a leap second in UTC is the responsibility of the International Earth Rotation Service (IERS). Without the addition of leap seconds, the sun would be seen overhead at midnight (rather than at noon) after approximately 50,000 years. UTC always differs from TAI by an integral number of seconds. In mid-2005, TAI was ahead of UTC by 32 s. UTC is the international standard for civil/legal time.

E. GPS Time

GPS time is an atomic time generated at the U.S. Naval Observatory that began on January 6, 1980. GPS time is not adjusted and is therefore offset from UTC by an integer number of seconds (s). Similar to the TAI and UTC offset, the GPS-time offset results from inserting leap seconds. GPS satellites broadcast the UTC-time offset in the navigation (NAV) message. GPS clocks receiving GPS time and the NAV message, apply the UTC-time offset correction automatically as a part of the lock sequence. In mid-2005, GPS time was ahead of UTC by 13 s, as shown in Fig. 3.

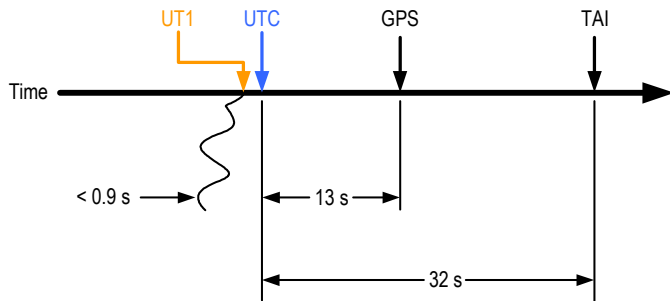

Fig. 3. Atomic Time Scale

III. GPS SATELLITES PROVIDE ACCURATE TIME SYNCHRONIZATION

GPS operations depend on a very accurate time reference, which is provided by atomic clocks at the U.S. Naval Observatory and each GPS satellite, which has four atomic onboard clocks. All of these satellite clocks are accurate to within a few nanoseconds (ns) of each other.

All GPS satellites synchronize operations so that their repeating signals are transmitted at the same instant. The signals, moving at the speed of light, arrive at a GPS receiver at slightly different times because some satellites are farther away than others. The distance to the GPS satellites can be determined by estimating the amount of time it takes for their signals to reach the receiver. When the receiver estimates the distance to at least four GPS satellites, it can calculate its position in three dimensions. Based on its three-dimensional position relative to the GPS satellites, the receiver is able to accurately calculate the propagation delay from each satellite. GPS receiver clocks use this method to synchronize their clocks very closely with the satellite clocks. However, there are several sources of inaccuracies:

- Time adjustments are made assuming that the radio signal propagation delays, based on the speed of light, are constant. In fact, the Earth's atmosphere slows the radio signals down slightly. The delay varies depending on what angle the received signal passes through the atmosphere.
- The propagation speed in the receiver antenna and antenna lead is different than free-space and the atmosphere. The propagation delay through the antenna lead will, therefore, vary with length. Some receivers compensate for this by assuming an average antenna lead length, others allow the user to input a delay setting. For long distances between antenna and receiver, some manufacturers provide repeating amplifiers that create an inherent incremental signal delay.
- Problems can also occur when radio signals bounce off large objects, such as adjacent buildings, giving a receiver the impression that a satellite is further away than it actually is.
- Satellites occasionally send out bad almanac data, misreporting their own position.
- Time jitter may occur when the satellite clock receiver loses lock with one satellite and achieves lock with another.

GPS satellite clock receivers compensate and adjust for many of these error sources. Overall, GPS satellite receiver clocks can be extremely accurate, but how accurate are they?

a) GPS clock accuracy:

GPS time requires that the atomic clocks on all of the satellites be synchronized with atomic clocks at the U.S. Naval Observatory. The GPS Civilian code (L1 frequency) has a time accuracy specification of 340 ns (2 standard deviations), however it typically performs at 35 ns.

Typical ratings of commercially available GPS clocks range from 50 ns to 1 ms. This rating is not an absolute value but a statistical probability. The unpublished or understood rating for these accuracies is 1 standard deviation (1σ). This implies, for example, that for a 50 ns clock with 1σ accuracy, the clock output will be within 50 ns, 66 percent of the time. When plotted together on a graph it is easier to visualize these numbers. Fig. 4 plots the 34 ns, 2σ (GPS time accuracy), and 50 ns, 1σ (typical GPS receiver module accuracy) together.

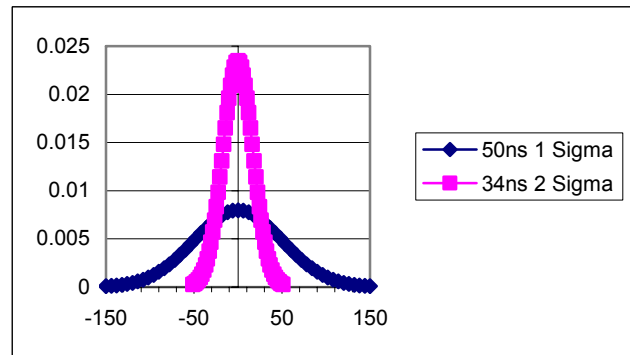

Fig. 4. Satellite Accuracy Versus GPS Receiver Accuracy

IV. IRIG TIME SYNCHRONIZATION SIGNAL FORMATS [2] [3]

Up to this point, this paper has discussed how GPS clocks develop stratum 1¹ time synchronization. Once the stratum 1 signal is received, it is used directly by the clock in the receiving device to display accurate time and disseminate a time signal to other devices in the vicinity of the local receiver. The format most commonly used to distribute the synchronized time information to downstream IEDs is defined by a standard that is now in widespread use; the IRIG Standard.

In 1956 the TeleCommunication Working Group (TCWG) of the American Inter Range Instrumentation Group (IRIG) was mandated to create a standard format for the distribution of synchronized time signals. This resulted in a standardized set of time code formats documented in IRIG document 104-60. The standard has been revised several times over the years, with the latest publication being 200-98.

¹ Stratum levels are used to indicate the traceability path from the atomic clocks operated by national standards organizations. They are stratum 0 clocks because they are the most accurate. However stratum 0 time sources cannot be used on the network. Stratum 1 time sources are directly traceable to national standards. Stratum 1 time sources get their time by direct connection to atomic clocks, through GPS transmissions, or through long-wave radio. Therefore, stratum 1 time sources act as the primary time standard. Stratum 2 time sources get their time from stratum 1 sources, and so on. Higher stratum levels (stratum 2, stratum 3, stratum 4, etc.) are deemed less accurate than their source due to transmission delays by about 10–100 ms per stratum level.

A. Description of IRIG Formats

The name of an IRIG code format consists of a single letter plus three subsequent digits. Each letter or digit reflects an attribute of the corresponding IRIG code. Table I contains standard code formats defined in IRIG standard 200-98. Code format names are composed as shown in Table II.

TABLE I
STANDARD CODE FORMATS—IRIG STANDARD 200-98

IRIG-A	IRIG-B	IRIG-D	IRIG-E	IRIG-G	IRIG-H
A000	B000	D001	E001	G001	H001
A003	B003	D002	E002	G002	H002
A130	B120	D111	E111	G141	H111
A132	B122	D112	E112	G142	H112
A133	B123	D121	E121		H121
		D122	E122		H122

TABLE II
EXPLANATION OF CODE FORMAT NAMES

First letter: Rate Designation	A	1000 PPS
	B	100 PPS
	D	1 PPM
	E	10 PPS
	G	10000 PPS
	H	1 PPS
	1st Digit: Form Designation	0
1		Sine wave carrier, amplitude modulated
2nd Digit: Carrier Resolution	0	No carrier (DCLS)
	1	100 Hz / 10 ms resolution
	2	1 kHz / 1 ms resolution
	3	10 kHz / 100 μ s resolution
	4	100 kHz / 10 μ s resolution
3rd Digit: Coded Expressions	0	BCD, CF, SBS
	1	BCD, CF
	2	BCD
	3	BCD, SBS

Abbreviations used in Table II.

- PPS: Pulses Per Second
- PPM: Pulses Per Minute
- BCD: Binary Coded Decimal. Coding of time (HH,MM,SS,DDD) where HH = hour of the day (00–23), MM = minutes of the hour (00–59), SS = seconds of the day (00–59), and DDD = day of the year (001–366)
- SBS: Straight Binary Second, a 17-bit-per-second of day in binary, representing 0...86400
- CF: Control Functions (depending on the user application)

B. IRIG-B

IRIG-B, as fully described in IRIG Standard 200-98, is a very popular format for distributing time signals to Intelligent Electronic Devices (IEDs). Time is provided once per second in seconds through day of the year in a binary coded decimal (BCD) format and an optional binary seconds of the day count. The format standard allows a number of configurations that are designated as B_{xyz} where x indicates the modulation technique, y indicates the counts included in the message, and z indicates the interval. The most commonly used forms for general time synchronization use are B122 (has seconds through day of the year coded in BCD and is amplitude modulated on a 1 kHz carrier) and B002 (a level shift format that

also has seconds through day of the year coded in BCD format). For higher accuracy applications, the B120, B121, B000, and B001 formats are used, when a block of 27 control bits are available to supplement the standard code for continuous timekeeping.

1) Control Function Bit Assignments

TABLE III
IRIG CONTROL FUNCTION BIT ASSIGNMENTS

IRIG-B Pos ID	Ctrl Bit #	Designation	Explanation
P 50	1	Year, BCD 1	Last 2 digits of year in BCD
P 51	2	Year, BCD 2	
P 52	3	Year, BCD 4	
P 53	4	Year, BCD 8	
P 54	5	Not Used	Unassigned
P 55	6	Year, BCD 10	Last 2 digits of year in BCD
P 56	7	Year, BCD 20	
P 57	8	Year, BCD 40	
P 58	9	Year, BCD 80	
P 59	-	P6	Position identifier # 6
P 60	10	Leap Second Pending (LSP)	Becomes 1 up to 59 sec before leap sec insert
P 61	11	Leap Second (LS)	0 = Add leap second, 1 = Delete leap second
P 62	12	Daylight Savings Pending (DSP)	Becomes 1 up to 59 sec before Daylight Savings Time (DST) change
P 63	13	Daylight Savings Time (DST)	Becomes 1 during DST
P 64	14	Time Offset sign	Time offset sign: 0 = +, 1 = -
P 65	15	Time Offset: binary 1	Offset from coded IRIG-B time to UTC time IRIG coded time plus time offset (including sign) equals UTC time at all times (offset will change during daylight savings).
P 66	16	Time Offset: binary 2	
P 67	17	Time Offset: binary 4	
P 68	18	Time Offset: binary 8	
P 69	-	P7	Position identifier # 7
P 70	19	Time Offset: 0.5 hour	0 = none, 1 = additional 0.5 hr time offset
P 71	20	Time Quality	4-bit code representing approx. clock time error
P 72	21	Time Quality	0000 = clock locked, maximum accuracy
P 73	22	Time Quality	1111 = clock failed, data unreliable
P 74	23	Time Quality	
P 75	24	PARITY	Parity on all preceding data bits
P 76	25	Not Used	Unassigned
P 77	26	Not Used	Unassigned
P 78	27	Not Used	Unassigned
P 79	-	P8	Position identifier # 8

IEDs may be programmed to check the control function bit field (shown in Table III) and use this additional information where it is provided. In general, the control bit assignments are made with zero indicating a normal state, because unused control field bits are normally set to zero. The rationale here is that this will minimize the possibility of creating a false alarm. For example, if a control field was all zeroes, the Time Quality indicator code would indicate the clock was locked with full accuracy (see Table IV), which would not accidentally be interpreted as an error condition.

Conversely, care must be taken to connect the IED, which uses the control bits, to an IRIG-B source that supports control bits. As the example above explains, if an IED is connected to an IRIG-Bxx2 source, for example, the placeholders for the control bits are all zero, indicating to the IED that the time quality is high accuracy, when, in fact, it may not be. The resulting time-tagging performed by the IED will be inaccurate, compared with other IEDs operating from high-accuracy IRIG-B sources that have the proper control bit assignments.

a) Time quality:

Of particular interest in the control function is the Time Quality indicator code, as defined in detail in Table IV. A four-bit Time Quality indicator code is used by several clock manufacturers and is in several existing standards. It is an indicator of time accuracy or synchronization relative to UTC and is based on the clock's internal parameters. The code presented here is by order of magnitude relative to 1 nanosecond (ns). The 1 ns basic reference is fine enough to accommodate all present industry uses now and into the foreseeable future. As an example, with GPS technology at better than 100 ns accuracy level, a 0000 code, indicating the source is locked, will go to a 0011 or a 0100 code when it loses lock.

TABLE IV
IRIG CONTROL FUNCTION TIME QUALITY INDICATOR CODE

Binary	Hex	Value (worst case accuracy)
1111	F	Fault—Clock failure, time not reliable
1011	B	10 s
1010	A	1 s
1001	9	100 ms (time within 0.1 s)
1000	8	10 ms (time within 0.01 s)
0111	7	1 ms (time within 0.001 s)
0110	6	100 μ s (time within 10–4 s)
0101	5	10 μ s (time within 10–5 s)
0100	4	1 μ s (time within 10–6 s)
0011	3	100 ns (time within 10–7 s)
0010	2	10 ns (time within 10–8 s)
0001	1	1 ns (time within 10–9 s)
0000	0	Normal operation, clock locked

2) IRIG-B Modulated and Demodulated Signals

Fig. 5 and Fig. 6 show the general structure of a demodulated (unmodulated) IRIG-B time code (Fig. 5), and a modulated IRIG-B time code (Fig. 6). The demodulated format is a pulse train of positive pulses at a rate based on the designated format. The signal is usually a 5-volt amplitude driving a 50-ohm load. The rising edge of the reference pulse coincides with the seconds change in the clock and provides a very precise time reference.

The modulated format is an amplitude modulated sine wave, with an amplitude between 1 V_{p-p} and 6 V_{p-p} for the mark (peak), with a mark-to-space amplitude ratio of approximately 3:1.

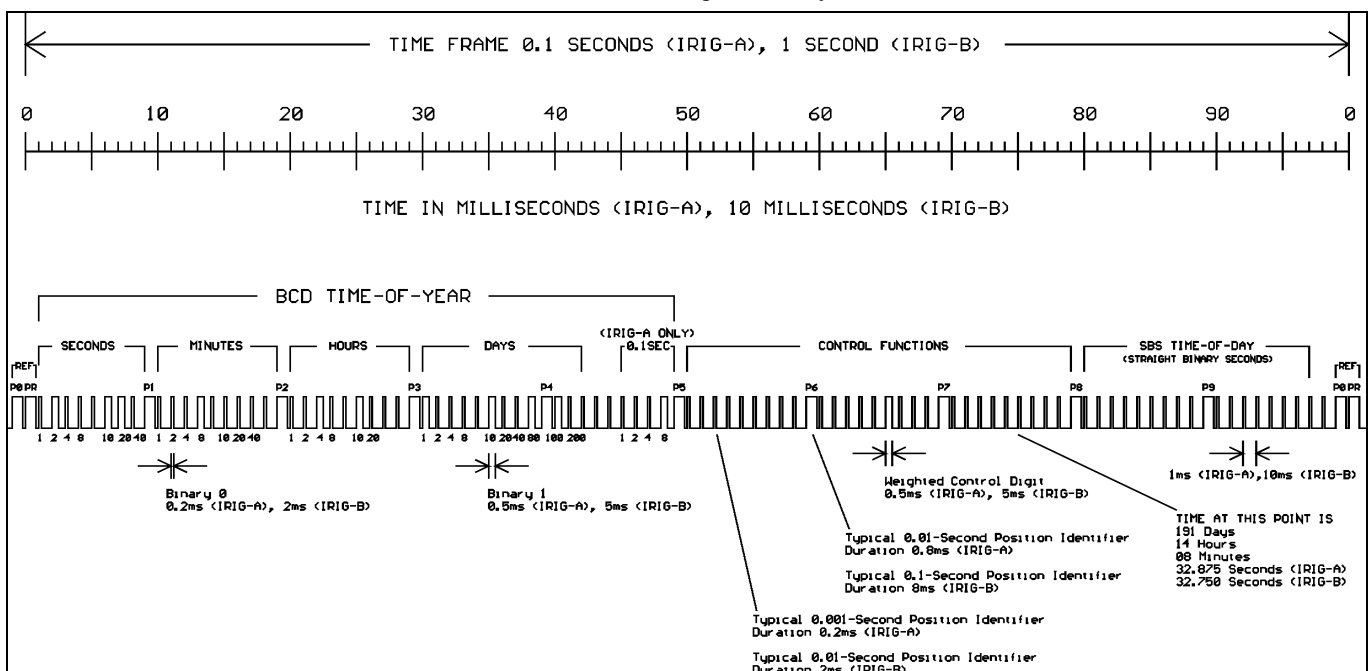

Fig. 5. Demodulated IRIG-A and IRIG-B Time Code Format

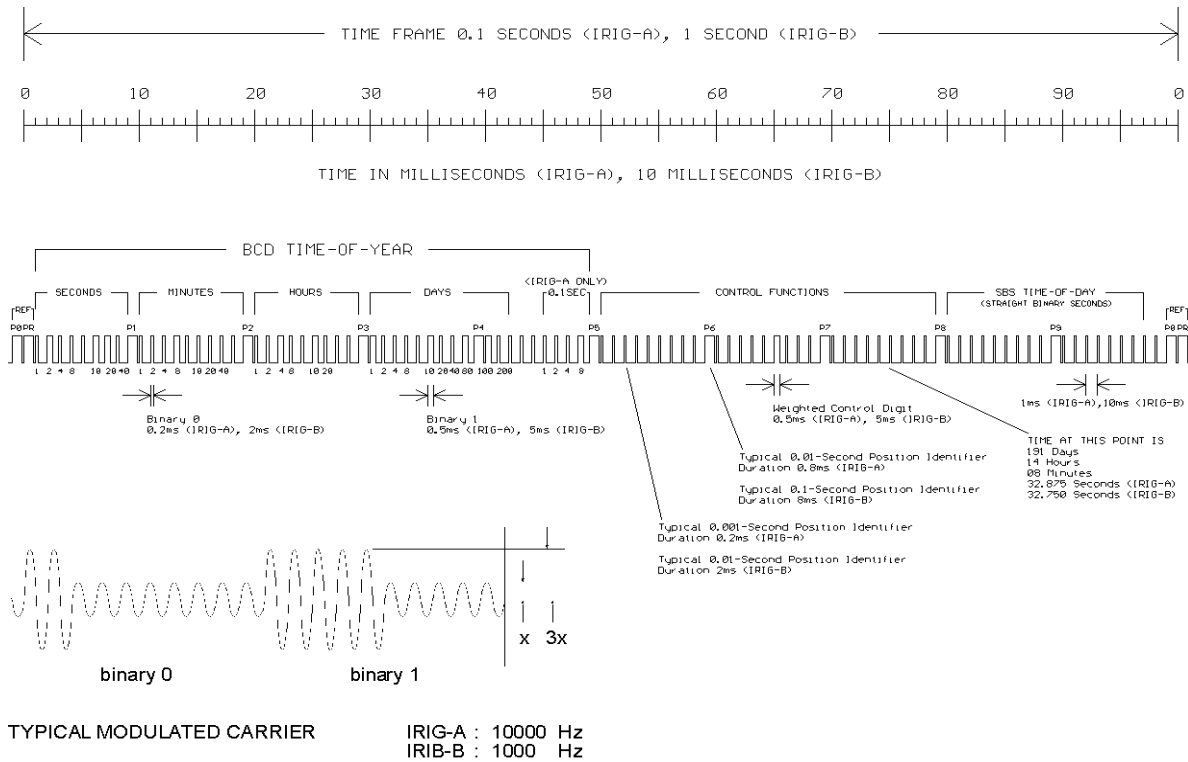

Fig. 6. Modulated IRIG-A and IRIG-B Time Code Format

V. IRIG TIME SYNCHRONIZATION ACCURACY

A. GPS Clock Accuracy

Accurate time synchronization begins with an accurate clock output signal. To better understand the accuracy differences between a 50 ns clock and a 1 ms clock, the five most popular GPS clocks used by power utilities where tested. The test setup shown in Fig. 7 used a common antenna with a splitter to ensure all clocks had the same input signal. The 1 PPS output of each clock was fed into a logic analyzer and compared to a time reference. The clocks tested had different operating temperature ranges; 0 and 50°C were the lowest and highest operating temperature for some of the clocks. The test was run for 10 hours at each temperature from 0 to 50° in 5° increments.

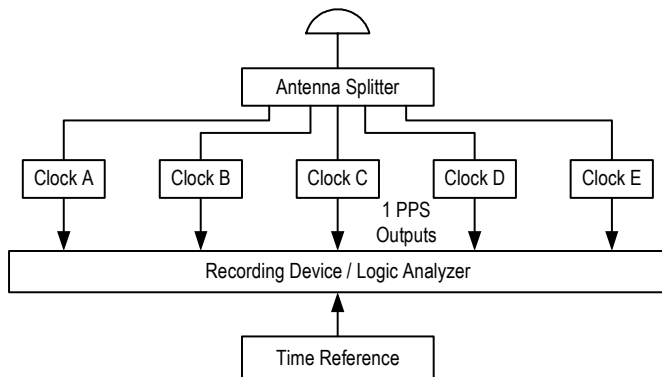

Fig. 7. Clock Accuracy Test Setup

The graph shown in Fig. 8 plots the resultant accuracy measured for the five clocks at 50°C for a ten-hour period. The data are superimposed over the graph in Fig. 4 to show how the actual performance measures up versus the predicted

performance. It is interesting to note that the measured data for all of the clocks are much better than the 50 ns, 1 σ rating of the GPS receiver. The list price range for these clocks was from \$1,500 to \$3,900 and the specified accuracy range was from 20 ns to 500 ns.

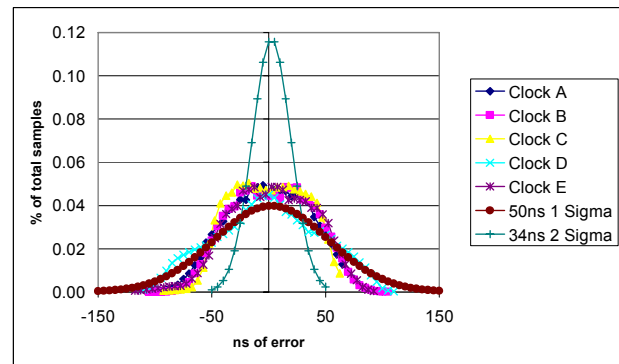

Fig. 8. Clock Accuracy Test Results at 50°C

This information does not mean that all GPS clocks are the same. However, how to state the accuracy ratings seems to be up to each manufacturer.

B. IRIG Time Signal Distribution

There are many ways to distribute the IRIG-B time signal to multiple IEDs. The following is an evaluation of the most common distribution methods used by power utilities.

The two most common formats used for IRIG-B transmission are modulated (IRIG-B1xx) and demodulated (IRIG-B0xx) as described in Section IV of this paper.

The IRIG-B modulated signal uses a 1 kHz carrier signal and provides a typical accuracy of 1 ms. The demodulated signal can provide accuracy in the nanosecond range, provided that its source supports that level of accuracy. The relative

inaccuracy of the modulated signal results from the zero-crossing method used to detect a shift between high- and low-bit status. At 1 kHz, the carrier signal zero-crossing occurs every 0.5 ms. A change in bit status, just after the last peak, will require an additional half cycle to detect the next peak, plus another quarter cycle to arrive at the next zero-crossing where the timing is measured. The major advantage of the modulated signal is its robustness. The modulated signal can be transmitted greater lengths and is not subject to ringing (overshoot) and reflections associated with fast rising and falling signal edges impinging on changes in the characteristic impedance of the propagation media. The modulated signal measurement technique compares the amplitude ratio of the “0” and “1” level signals, so the absolute magnitude is of less consequence. Therefore the signal attenuation over an extended cable run is of little consequence as long as the two signal levels are still measurable. The modulated signal is sometimes accompanied by a 1 PPS signal to provide higher accuracy time synchronization. The data, including time-of-the-day and day-of-the-year, are carried in the modulated signal, and the mark specifying the precise change of second is provided by the 1 PPS signal. The disadvantage to this scheme is that the IED must have two time code inputs, one for IRIG-B and one for 1 PPS.

Due to the fast rising and falling edges on the demodulated signal, ringing and reflections can occur if the distribution cable is not properly terminated. Also, the measurement technique required to detect “1s” and “0s” is based on a specific amplitude threshold. Therefore signal attenuation over a long cable run or because of heavy signal loading, is more critical with the demodulated signal than with the modulated signal.

Signal propagation delay must also be considered in very high-accuracy timing requirements. Cable capacitance and the cable propagation constant (ratio of the speed of light in free-space compared with the propagation speed in the cable medium), must be considered. The rising edge of square wave pulses used in demodulated signal distribution can become rounded and delayed, causing measurement inaccuracies, as shown in Fig. 9.

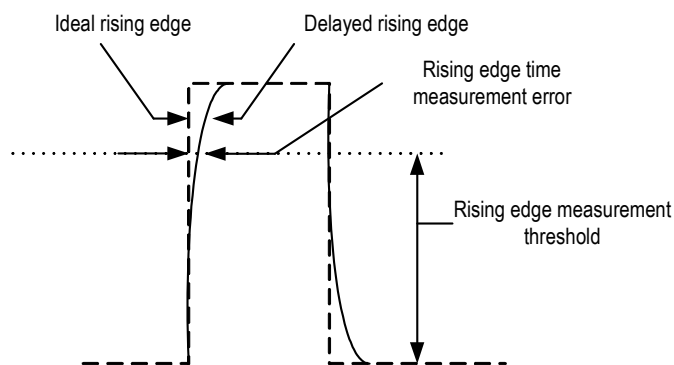

Fig. 9. Demodulated Signal Rising Edge Measurement Error

1) Signal Distribution Media

The IRIG-B signal, modulated or demodulated, is most commonly distributed electrically through simple shielded, twisted pair, or via coaxial cable. In power substations, electrical noise and ground potential rise limit the length of these

electrical conductors to 100 ft or less, preferably no more than 50 ft. Longer distances may be achieved by converting the ground-referenced signal to a differential signal, similar to RS-422 communication. However, distribution of IRIG-B through metallic cable, regardless of the format, should be restricted to within the same building. Short metallic cable runs also minimize signal accuracy errors due to signal propagation delay and attenuation.

Extending the signal outside the control building to other buildings or electrical apparatus within a substation should be done using optical fibers, which are immune to electrical interference and ground potential rise. Converting to an optical signal causes data latency and has its own set of propagation delay and attenuation limits. Converting the electrical signal to an optical signal and back to electrical creates a latency of about 15 μ s; plus another 5 μ s delay per km of fiber. The total distance that the signal can be transmitted through fiber is also restricted by the optical budget of the optical transceivers, and the attenuation losses in the optical fiber, including splice losses. For example, a simple 850 nm optical transceiver with a 15 dB optical budget could transmit an IRIG signal up to 5 km, assuming an optical fiber attenuation of 3 dB/km at 850 nm. The propagation delay over this length of fiber would be 40 μ s, including the latency in the transceivers and optical fiber.

Multiplexing the IRIG signal with other data over an optical fiber creates latencies that may vary depending on the modulation technique and the relative priority that the IRIG signal is given relative to the other data.

Multiplying a single IRIG signal for distribution to multiple IEDs through a communications processor, for example, will also create latencies in the signal path.

Fig. 10 shows an example of several methods used to distribute the IRIG-B time synchronization signal.

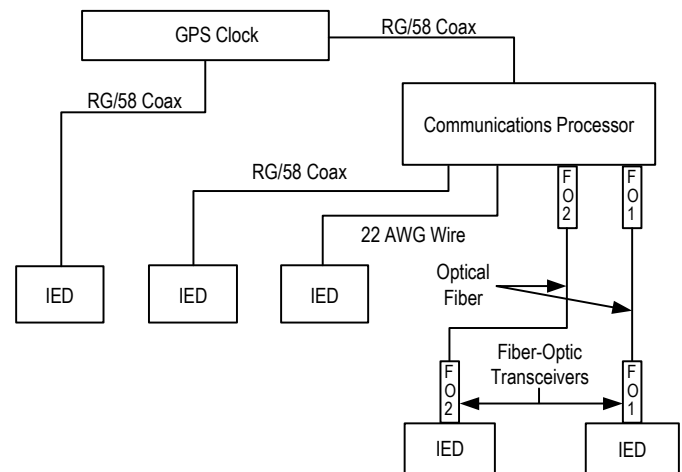

Fig. 10. Typical Substation IRIG-B Signal Distribution Connections

2) IRIG-B Time Distribution Latencies

To examine the relative propagation delays in metallic cable and fiber, a test configuration shown in Fig. 11 was assembled. The signal latency was measured using a dual trace oscilloscope. Table V lists the propagation delay measured across various IRIG signal distribution media using the test connection shown in Fig. 11.

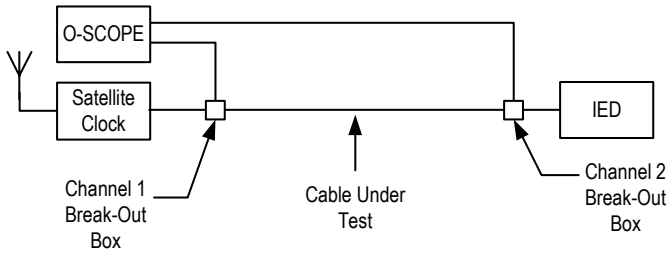

Fig. 11. IRIG-B Signal Propagation Delay Test Connection for Cables and Fiber

TABLE V
PROPAGATION DELAY MEASUREMENTS

Cable Type	Tested Length	Tested Delay	Delay/unit
Twisted Copper	100 ft	190 ns	1.90 ns/ft
Coaxial	135 ft	250 ns	1.85 ns/ft
Fiber	0 ft	Not tested	5 μ s / km

The signal distribution latency in a communications processor was measured using the configuration shown in Fig. 12. Latency measurements were also made for fiber-optic transceivers; these measurements are made on the electrical input and output of the fiber-optic transceivers used to convert the demodulated IRIG-B signal to and from the optical signal. The fiber-optic transceivers used in this test are designed to multiplex the IRIG signal with a data signal. The test results for the latency measurements are shown in Table VI.

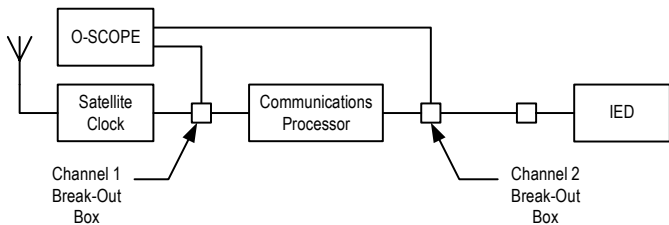

Fig. 12. IRIG-B Signal Distribution Latency Test Connection for a Communications Processor

TABLE VI
LATENCY MEASUREMENTS

Device	Delay Time
Communications Processor	2.10 μ s
850 nm Fiber-Optic Transceiver	5.26 to 8.98 μ s
650 nm Fiber-Optic Transceiver	17.8 to 69.0 μ s

3) IRIG-B Demodulated Signal Distortion

Signal distortion is also a source of errors in the distribution of IRIG-B signals, particularly for demodulated signals with fast edges. Ringing and reflections cause signal distortion and jitter that can cause IEDs to misinterpret the signal. From the latency tests reported in Table V and Table VI, it is apparent that high-accuracy applications, requiring sub-microsecond time synchronization, must be distributed directly on cable. Communications processors and fiber-optic transceivers insert two to several microseconds of delay in the communications path. Coaxial and direct twisted-pair cable, up to 135 ft in length, add a .25 μ s delay or less.

Metallic cables must be properly connected and terminated to prevent excessive signal distortion. To demonstrate this, the test configuration shown in Fig. 13 was used to observe the

IRIG-B demodulated signal on each end of a 125 ft coaxial cable, where the cable supplies a signal to an IED.

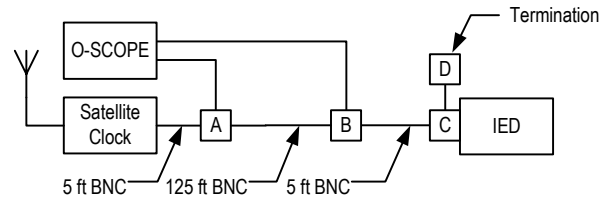

Fig. 13. Coaxial Cable Test for Observing IRIG-B Demodulated Signal

The charts in Fig. 14 and Fig. 15 show the waveforms for a rising edge and falling edge of a high current (>100 mA) demodulated signal, with and without proper cable termination. In this case, a 50-ohm termination resistor was used to properly terminate a coaxial cable with a 50 ohm characteristic impedance. The traces of each plot are labeled to indicate the measurement location per Fig. 13 and the test conditions were either terminated or un-terminated. A 125 ft RG-58 coaxial cable was used to demonstrate the ringing and signal overshoot that can occur. The voltage scale for Fig. 14 and Fig. 15 are 5 volts per division. Very visible in Fig. 14 is the signal overshoot and ringing on the un-terminated signal. If the overshoot crosses the detection voltage threshold for a device, false triggers can occur, resulting in timing discrepancies and possible data corruption.

On the falling edge trace, the un-terminated signal voltage is delayed by the cable capacitance. This falling edge delay does not affect the timing accuracy; however, if delayed enough, signal corruption may result.

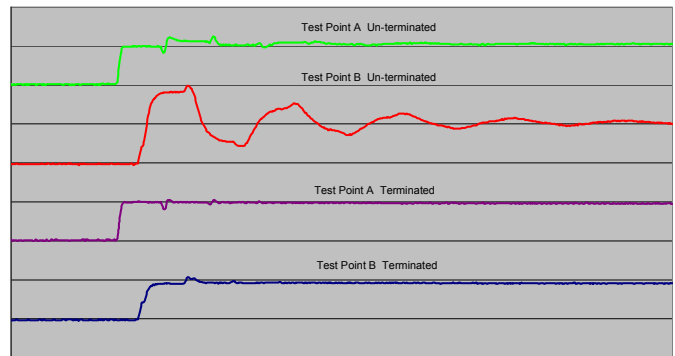

Fig. 14. Unmodulated Rising Edge

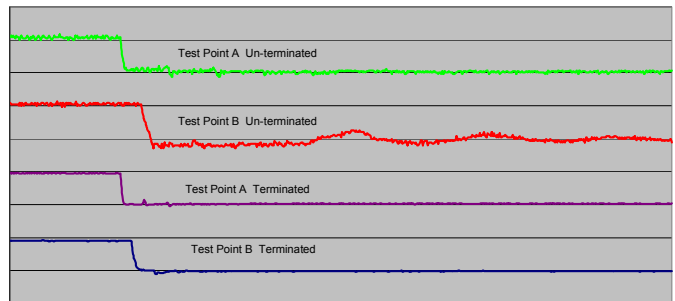

Fig. 15. Unmodulated Falling Edge

C. IED Synchronized Time Processing

The way that IEDs process the IRIG time synchronization signal may be as important as the time signal distribution process. IEDs typically use an IRIG signal to update their on-

board clock and calendar in a background mode. The period between reading the signal may vary depending on how busy the processor is with higher priority functions. The onboard clock time may lose accuracy, depending on the stability of the clock oscillator between IRIG signal reads. IED clock oscillators are typically based on a quartz oscillator, which has a calibration tolerance and temperature sensitivity. Under extreme temperature conditions, with maximum period between time synchronization updates, the onboard clock may drift by a significant margin, possibly up to a few milliseconds.

To achieve the highest possible IED clock accuracy, the IED must regularly read and process the IRIG time synchronization signal every second.

VI. OTHER ERROR SOURCES

A. IED Sampling Rate and Processing Interval Versus Time Accuracy

IEDs digitize input data as often as their sampling rate permits. Sampling rates on protective relays vary from four samples-per-cycle to hundreds of samples-per-cycle. Digital fault recorders typically sample data up to hundreds of times per cycle. If an event occurs just after the last time the IED sampled the input, then there could be up to a one-sample-period error between when the event occurred and when the IED time tagged its occurrence.

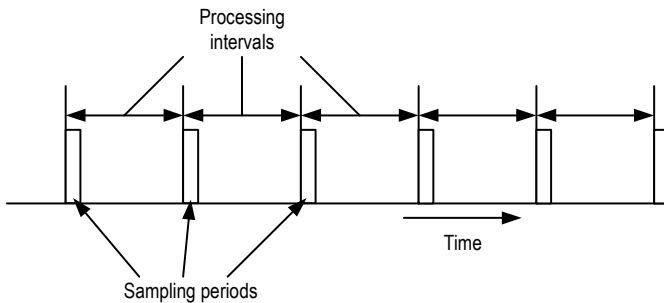

Fig. 16. Analog and Digital Inputs Are Sampled at the Beginning of Each IED Processing Interval

Sampling on analog and digital inputs is very often performed in a sequential manner within the sampling period. All samples taken during the period are tagged with the same time, so small errors will exist between the time the sampling actually occurred, and the time the tag is assigned to the sample. Generally these errors are small because the sampling process takes up only a small portion of the processing period. The remainder of time in the processing interval is used to process the data and perform other background functions.

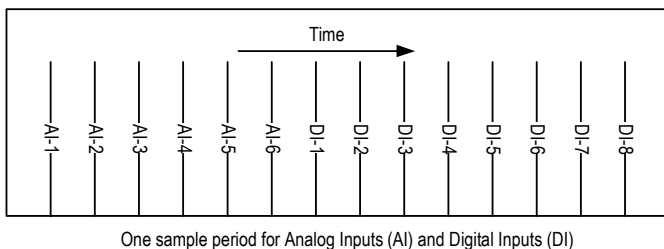

Fig. 17. Analog and Digital Inputs Are Sequentially Sampled During Each Sample Period

More sophisticated IEDs will have multiple processors, so the sampling and data processing functions can be dedicated to a single processor, while other processors perform background functions that have variable demand. In this way, the IED can achieve consistent sampling and time tagging during even the most demanding conditions.

Some IEDs perform multiple analog samples within a processing interval. This improves the resolution of analog data, and provides a wider frequency spectrum in the raw analog data. Digital inputs are typically sampled once every processing interval.

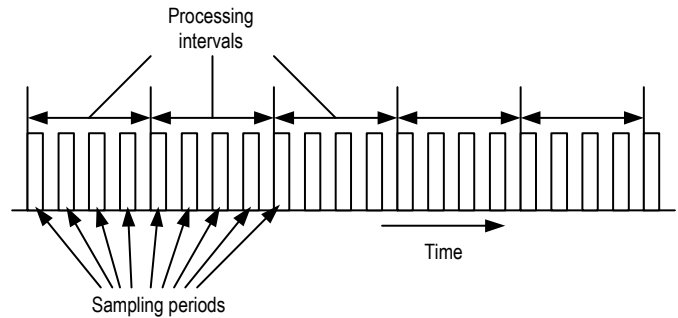

Fig. 18. Multiple Sampling Periods per Processing Interval in IEDs

B. IED Filtering

1) Analog Signal Input Filtering

IEDs, such as protective relays that operate on fundamental frequency analog quantities, require filtering to separate the fundamental frequency quantity from harmonics. Analog filtering in IEDs is typically comprised of a low-pass anti-aliasing hardware filter, and a band-pass digital filter. Filtering delays naturally occur, skewing the recorded fundamental analog signal with respect to the original sampled data. The skew caused by the low-pass hardware filter is usually minor. Some IEDs record both the raw sampled data (obtained from the output of the low-pass filter before it enters the digital filter) and the filtered data, as shown in Fig. 19.

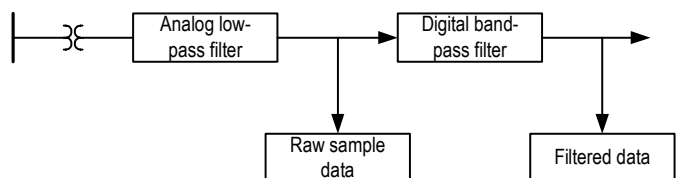

Fig. 19. Some IEDs Capture Raw and Filtered Data

2) Digital Signal Input Filtering

To avoid false digital input recording caused by spurious noise, some IEDs “debounce” the digital inputs by requiring that the input be high (asserted), or low (deasserted) for more than one sampling period before recognizing that the digital input changed state. This debounce delay skews the time tag applied to a state change unless the IED adjusts the time tag to compensate for the debounce delay. Some devices may offer two time tags, one for the raw input state change and the other for the debounced input state change.

3) Instrument Transformer Error

Current and voltage analog signals presented to IEDs are scaled from primary values to secondary quantities by instru-

ment transformers; current transformers (CTs) and voltage transformers (VTs). These instrument transformers are designed to faithfully reproduce the primary quantities on their secondary outputs. However, all electromagnetic CTs and VTs induce slight phase shifts due to the inherent losses and magnetic storage capacity of iron-core magnetic circuits. Capacitive voltage transformers (CVTs) also include iron-core magnetic circuitry that produce slight phase shifts between primary and secondary analog signals.

VII. POWER SYSTEM APPLICATION REQUIREMENTS

The electric power industry uses synchronized time signals for the following applications:

- Power system fault and disturbance recording devices
- Sequence-of-events recorders
- Precision synchrophasor measurement units
- Test equipment at adjacent stations for synchronized end-to-end testing
- Energy Management Systems (EMS) for SCADA analog and state-change recording

A. Power System Fault and Disturbance Recording

Oscillographic data-recording devices, including digital protective relays and fault recorders that record power system faults for post-disturbance analysis, can be adequately synchronized with millisecond resolution time. A single fault may trigger oscillographic data-recording by devices at multiple locations on the power system. Records from multiple sources may be required to accurately assess the type, severity, and duration of the fault and check for proper operation of protection and control equipment. While it is sometimes possible to compare general characteristics of fault data to determine which records were triggered by the same fault, accurate time tags associated with the records are a tremendous aid, especially for major disturbances and when multiple faults occur within a short time period. Event record time tags, which are accurate to within a few milliseconds, are adequate to determine how multiple records “fit” together chronologically to analyze the sequence in which events occurred.

NERC Recommendation 12a, based on the August 14, 2003 blackout analysis, strongly recommends “use of time-synchronized data recorders” and the installation of “additional time-synchronized recording devices as needed.” These recommendations are the result of collecting numerous disturbance records with completely inaccurate time stamps, some with not only the wrong time of the day but with inaccurate day, month, and even year! Countless hours and days were spent piecing together disturbance records to perform root cause analysis of this blackout. Accurately time-tagged records greatly simplify the task for simple outage analysis, as well as for large-scale disturbance and blackout analysis. The most recent NERC proposal [4] is that events be time tagged within one quarter cycle (approximately 4 ms) accuracy.

It is important to recognize that fault and disturbance records are time recordings that span several cycles to several seconds of time. The time tag associated with the record must have a specific and known reference within the record. Typi-

cally, a fault or disturbance detector triggers the record, so the time tag is typically associated with the detector operation. The record should clearly show when the detector picked up, so the specific time associated with the record time tag can be identified in the record. This indication may be in the form of a timing mark in the oscillographic record or by actually displaying a time scale with the record. The minimum resolution provided by the time tag or applied with the time scale should be 1 ms.

It is also important to recognize that digital recording devices have a sampling rate. If the sampling period is greater than the accuracy of the device time source, then the accuracy of the event report time tag is only as accurate as the resolution of the sampling period, plus or minus the clock accuracy. For example, a device clock may be synchronized within plus or minus 1 ms of UTC time. If the sampling rate of the IED is eight times per power system cycle at 60 Hz, then the device sampling period is every 2.08 ms. The resolution of the time tag may be 1 ms, but the accuracy of the time tag is therefore 2.08 ms, plus or minus 1.0 ms.

B. Sequence-of-Events Recording

Sequence-of-events recorders produce Sequential Events Reports (SER) or Sequence-of-Events (SOE) reports that provide a chronological list of when monitored devices changed state. Changes of state may be opening or closing, asserting or deasserting, turning on or turning off, etc. Device monitor points may include circuit breaker status contacts, protective relay and teleprotection contact outputs, and, in today’s IEDs, logical status on internal logic elements.

Each sequence-of-events recorder creates a chronological list of its monitored device state changes. Observing the sequence in which events occurred can be very helpful when troubleshooting device operation and for post-disturbance analysis. Like the time tags applied to oscillographic event reports, the time tags applied to device state changes should be synchronized with other sequence-of-events reports to assist in the analysis of device operations associated with power system disturbances. Like the oscillographic event report, event time accuracy within a few milliseconds is typically adequate. Typical specifications for power system SER and SOE devices require 1 ms time-tag accuracy.

Like oscillographic event recorders, the sequence-of-events recorder’s sampling period impacts the overall accuracy of the time tag associated with the logged state change. In addition, status inputs may be debounced to avoid recording spurious input assertions. Knowing how these inputs are treated by the sequence-of-events recorder is important to the overall time comparison of state changes between and within event reports.

C. Precision Synchrophasor Measurement

The technology required to perform wide-area measurement and control is progressing rapidly. This technology has the potential to provide operating personnel with improved visibility of power system status and health through the real-time comparison of voltage and current phasors from select points on the power system. The August 13, 2004 blackout occurred, in part, because operators, at widely separated oper-

ating centers, were unable to recognize that the system was slowly breaking apart. NERC states in their blackout report and recommendations, “Time-synchronized devices, such as phasor measurement units, can also be beneficial for monitoring a wide-area view of power system conditions in real time...” [4].

With proper communication and programming, wide-area measurement also has the potential to provide remedial action controls that could mitigate cascading failures and prevent blackouts.

The concept of synchronized phasor measurement involves synchronizing the sampling of all associated devices, no matter where they are in the system, such that each device creates a reference phasor by which to measure the relative magnitude and angle of real-time voltage and current phasors at its location. Because all phasor measurements are made using the same synchronized reference, all phasor measurements from different locations on the system, but with identical time tags, can be compared with each other to determine the relative phase relationships across the system. Fig. 20 shows the concept of a reference phasor with associated phase shift, relative to measured current and voltage. Phasor data are collected from various locations around the system as shown in Fig. 21. The collected phasor data are time aligned and plotted to provide a visual comparison of the real-time phasor relationships, as shown in Fig. 22.

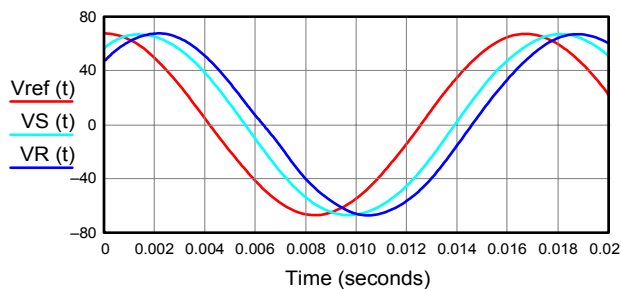

Fig. 20. Synchrophasor Reference Developed From Synchronized Time Input

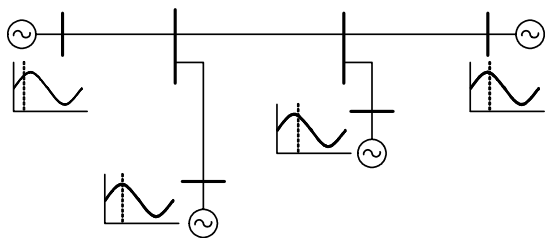

Fig. 21. Phasor Data Collected Throughout System

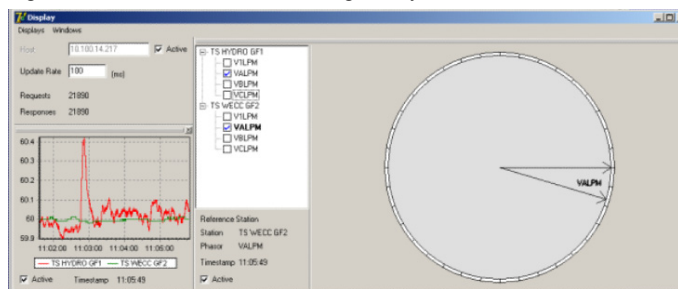

Fig. 22. Graphical Plot of Synchrophasor Data

One of the key requirements for synchrophasor measurement is the precise synchronization of sampling between devices located across the system and the subsequent comparison of the phasors developed from those samples. Existing IEEE Standard 1344-1995, “Standard for Synchrophasors for Power Systems,” and its proposed replacement, PC37.118, “Draft Standard for Synchrophasors for Power Systems,” states, “synchrophasor measurements shall be synchronized to UTC time with accuracy sufficient to meet presently undefined requirements.” These requirements are not yet defined because this is an emerging technology that will be applied in ways not yet fully explored. It is generally accepted that the time synchronization of samples should be accurate to within 1 μ s. Note that a time error of 1 μ s corresponds to a phase error of 0.022 degrees for a 60 Hz system and 0.018 degrees for a 50 Hz system. The synchrophasor standards call for a Total Vector Error (TVE) of less than one percent. This corresponds to a maximum time error of ± 26 μ s for a 60 Hz system, and ± 31 μ s for a 50 Hz system. However, the TVE is a summation of errors from time synchronization, instrumentation conversion, and phasor measurement processing errors. Table VII shows the relative magnitude of errors from these sources [5]. While the time synchronization error is the least of these, it is quite obvious that it must be small to prevent the total error from reaching a TVE of one percent.

TABLE VII
ERRORS IN SYNCHRONIZED PHASOR ESTIMATION AND TYPICAL
CORRESPONDING VALUES

Error Cause	Error in Degrees	Error in Microseconds
Time Synchronization	0.0216	1
Instrument Transformers (Class 0.3)	0.3	14
Phasor Estimation Device	0.1	5

D. Test Equipment at Adjacent Stations for Synchronized End-To-End Testing

Modern, high-speed, line protection schemes using pilot communication can be tested more realistically by performing synchronized tests at each line terminal. These tests can simulate internal and external line faults, which then involve the operation of the teleprotection equipment and communications channels to simulate actual end-to-end scheme performance.

The tests can be performed by injecting prefault and fault currents and voltages into the relays at each end and starting at precisely the same time to provide the proper phase alignment between the two terminals that would be expected under real line-fault conditions.

On directional comparison pilot protection schemes, it is most important to start the fault simulation at the same time at both ends. The relative phase angle of injected test quantities is not important because the two terminals are only sharing logical status information through the communications channel, not measured analog quantities. Timing of the communications signals in the pilot protection schemes is the most critical element of these tests. Generally, tests initiated within

less than a few milliseconds of each other will provide acceptable results.

Timing is more critical on phase comparison and line current differential schemes, where the relays share current phase angle information across the communications scheme. One millisecond is roughly equivalent to 22 electrical degrees at 60 Hz. On some schemes, a 22-degree difference between current phase angles may be enough to cause the relay scheme to misoperate. Timing accuracies of 1 ms or less are desirable for end-to-end testing on these schemes.

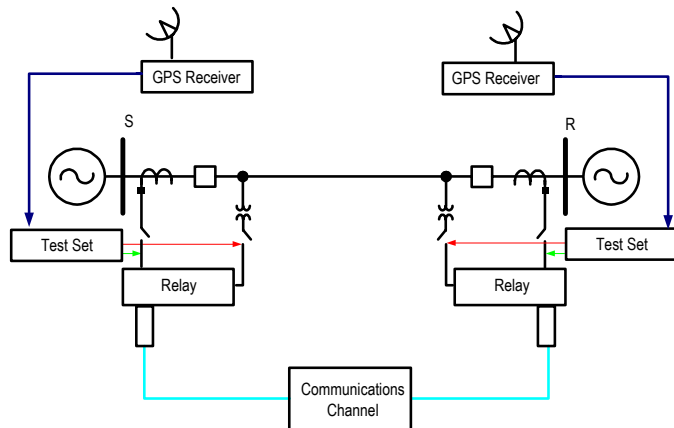

Fig. 23. Synchronized End-to-End Testing Configuration

E. Energy Management Systems for SCADA Analog and State-Change Recording

Energy Management Systems (EMS) designed for System Control And Data Acquisition (SCADA) log event data for post disturbance analysis. Older systems polled Remote Terminal Units (RTUs) for status changes, logging the time of the status change based on when the RTU was scanned. The time tag associated with the status change could be off by as much as the time between scans, sometimes by as much as several seconds. More modern SCADA systems log the time of the status change in the RTU and retrieve that information with the other polled data. This requires that the RTU have an on-board clock synchronized to the other RTUs on the system. Even more modern systems retrieve time-tagged SER data from lower-tier IEDs through protocols like DNP. This pushes the requirements for time synchronization down to the IED level. Some SCADA systems are able to disseminate a time synchronization signal from the SCADA master to the RTU or an intelligent communications processor at each substation. The RTU or communications processor may also pass this time synchronization signal to the IEDs. Disseminating the time synchronization signal through multiple tiers creates synchronization latencies of a few to several milliseconds per level. That may be tolerable in some systems. For more accurate state-change time-tagging, the IEDs should be synchronized from a clock located at each substation. This is illustrated in Table VIII.

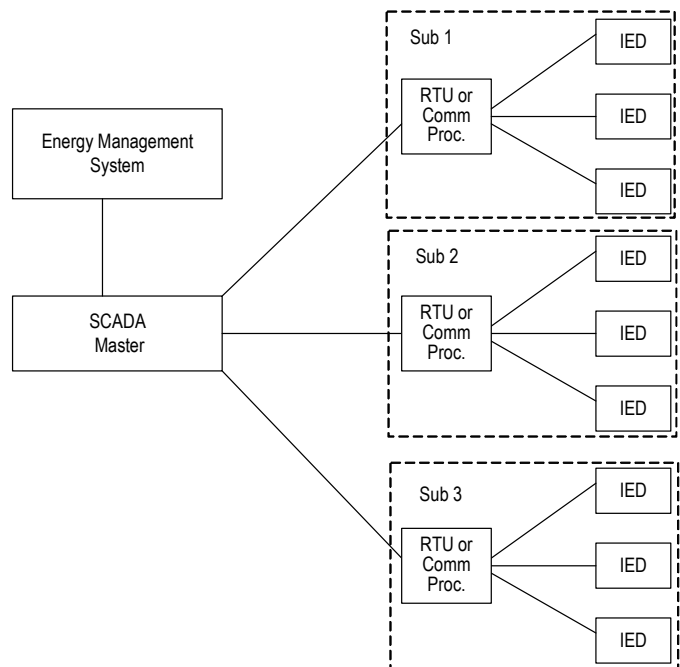

Fig. 24. Energy Management System for Three Substations

As in SER and SOE applications, time tagging change-of-state information in EMS/SCADA systems to within a few milliseconds on a system-wide basis is more than acceptable.

TABLE VIII
SUMMARY OF TIME SYNCHRONIZATION REQUIREMENTS

Application	Acceptable Overall Time Error	Time Synchronization Accuracy
Fault disturbance recording	Within a few ms	1 ms
SER/SOE	< 1 to few ms	< 1 to 1 ms
Synchrophasor measurements	< 26 μ s	1 μ s
Synchronized end-to-end testing	< 1 to few ms	< 1 to 1 ms
EMS/SCADA	Within a few ms	1 ms

VIII. CONCLUSIONS

It should be said, that after a thorough review of time synchronization techniques, there is really no such thing as the “perfect time.” Errors and latencies exist in all forms of synchronization technologies and in their methods of distributing time signals. It also can be observed that nothing happens instantaneously, so trying to put a precise time tag on a non-precise event is fruitless. Having said this, the technology exists today to provide substantially improved power system monitoring, protection, and control through the use of modern time synchronization techniques and microprocessor-based devices.

Most applications for power system monitoring and recording are satisfied with time synchronization accuracy to within 1 ms. The evolving technology of wide-area measurement and control using synchronized phasor measurement requires time synchronization accuracy to within 1 μ s. Both of these are achieved with relatively simple and economical

clock receivers, thanks to the development of GPS time and the availability of GPS satellites to disseminate that time throughout the world. Other technologies are developing, but GPS satellite receiver clocks offer the most widely available and traceable source of high-accuracy time synchronization.

High-accuracy IED time synchronization can be achieved by direct-connecting the IED to the GPS receiver clock high-accuracy IRIG output using metallic twisted pair or coaxial cable. To minimize signal distortion caused by ringing and signal jitter caused by reflections, the cable must be properly terminated with a resistor matching the cable characteristic impedance. The use of fiber-optic transceivers, optical fiber, and communications processors, which incur delays of two to several microseconds, must be avoided for time synchronization in order to achieve sub-microsecond time synchronization accuracy required for synchronized phasor measurement.

IRIG signal distribution through fiber-optic transceivers and communications processors is acceptable for a broad range of moderate accuracy applications, such as fault disturbance report and sequential event time tagging, SCADA, and synchronized end-to-end line relay testing. These applications are quite easily satisfied using modern satellite clock receivers and well-established time-synchronization signal distribution methods. Care must be taken to ensure that the IEDs connected to a clock output do not overload the output circuits or create excessive attenuation in the signal distribution circuit.

IX. APPENDIX

A. Terrestrial Time Synchronization Sources

1) Terrestrial Broadcast Sources [2] [6]

Terrestrial sources of synchronized time include radio broadcast through the atmosphere or a broadcast over a controlled medium such as fiber optics. Radio broadcasts are probably the least expensive but are the most susceptible to interference and usually have the lowest accuracy. Microwave and fiber-optic systems can achieve high accuracy but have higher installed costs.

a) WWV and WWVH radio broadcast [2]

WWV broadcasts on 2.5, 5, 10, 15, and 20 MHz from Fort Collins, Colorado. WWVH broadcasts on 2.5, 5, 10, and 15 MHz from Kauai, Hawaii. Both stations continuously broadcast a timing signal (24 hours a day, 7 days a week) to listeners all over the world. However, the radio transmission patterns are designed to primarily serve listeners in North America.

Multiple frequencies are used because shortwave propagation varies with many factors, including time of year, time of day, geographic location, solar and geomagnetic activity, weather conditions, and antenna type and configuration. In

general, the lower frequencies of 2.5 and 5 MHz are best during nighttime hours, the higher frequencies of 15 and 20 MHz are better during daytime hours, and 5 and 10 MHz are probably the best compromises overall. The 5, 10, and 15 MHz transmissions are at higher power than the other frequencies.

The time is kept to within less than 1 μ s of UTC at the transmitter site, but the signal is delayed as it travels from the radio station to the receiver location. This delay increases the further the receiver is from the station and also changes at various times during the day if the signal is bouncing between the earth and the ionosphere. However, for most users in the United States and North America, the received accuracy should be less than 10 ms.

The signal sent on WWV and WWVH is a series of tones, beeps, and clicks synchronized to one-per-second, with a voice announcement of the time prior to each minute change, such as, "at the tone." The time announced on WWV and WWVH is UTC.

The WWV and WWVH radio signals are not suitable for synchronizing modern power system IEDs because of their relative inaccuracy and because it is difficult to convert the announced time to a coded digital signal.

b) WWVB radio broadcast [2]

NIST radio station WWVB is located on the same site as WWV near Fort Collins, Colorado. The WWVB broadcasts are used throughout North America to synchronize consumer electronic products like wall clocks, clock radios, and wristwatches. In addition, WWVB is used for high-level applications such as network time synchronization and frequency calibrations.

WWVB continuously broadcasts time and frequency signals at 60 kHz. The carrier frequency provides a stable frequency reference traceable to the national standard. There are no voice announcements on the station, but a time code is synchronized with the 60 kHz carrier and is broadcast continuously at a rate of one bit-per-second using pulse width modulation. The carrier power is reduced and restored to produce the time code bits. The carrier power is reduced 10 dB at the start of each second, so that the leading edge of every negative going pulse is on time. Full power is restored 0.2 s later for a binary "0," 0.5 s later for a binary "1," or 0.8 s later to convey a position marker. The binary coded decimal (BCD) format is used so that binary digits are combined to represent decimal numbers. The time code contains the year, day of year, hour, minute, second, and flags that indicate the status of Daylight Savings Time, leap years, and leap seconds. The WWVB time code format is shown in Fig. 25.

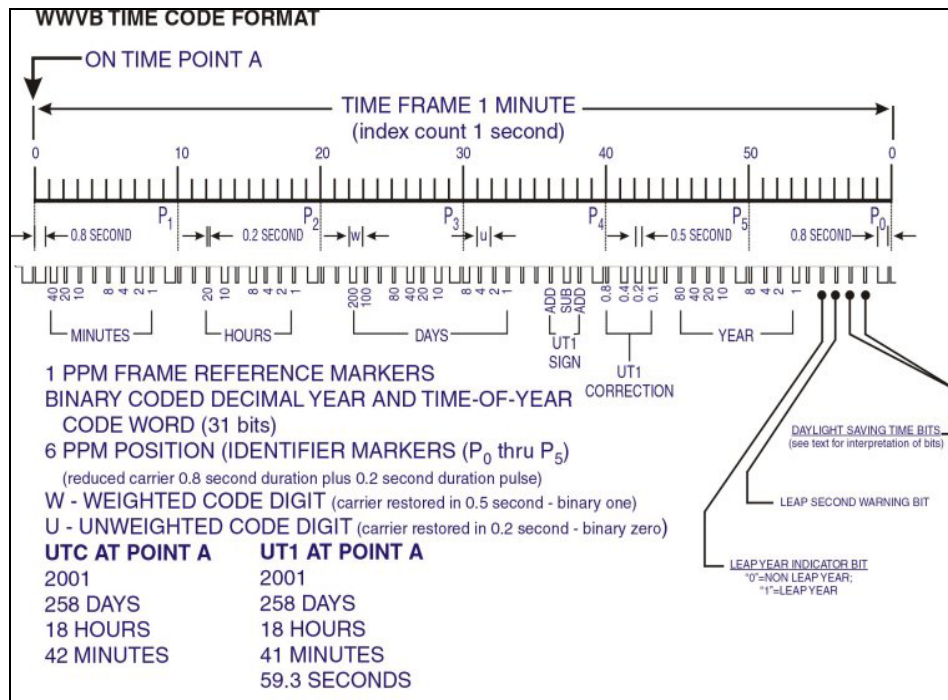

Fig. 25. WWVB Time Code Format



Fig. 26. LORAN-C Coverage Areas, (Picture Courtesy of Megapulse) [7]

The frequency uncertainty of the WWVB transmitted signal is less than one part in 1×10^{12} . If the path delay is removed, WWVB can provide UTC with an uncertainty of less than $100 \mu\text{s}$. The variations in path delay are minor compared to those of WWV and WWVH. When proper receiving and averaging techniques are used, the uncertainty of the received signal should be nearly as small as the uncertainty of the transmitted signal.

The higher accuracy, and coded format of the WWVB signal makes it much more desirable than WWV and WWVH signals for synchronizing modern power system IEDs. However, the radiated frequency caused by coronal discharges in 60 Hz power stations can severely interfere with the 60 kHz carrier frequency of the WWVB signal. For this reason, the WWVB signal is seldom used in utility substations to time-synchronize modern IEDs. However, it is used for synchronizing EMS system clocks and other power system control equipment not located at high-voltage electric power stations. It is primarily available for North America, so it is not considered a universal source of time synchronization.

c) LORAN-C [7]

Long Range Navigation (LORAN-C) was originally developed to provide radionavigation service for U.S. coastal wa-

ters and was later expanded to include complete coverage of the continental U.S. as well as most of Alaska. Numerous U.S.-based LORAN-C stations, and several European- and Asian-based stations work in partnership to provide coverage in North America and the major navigation routes in coastal waters, as shown in Fig. 26.

LORAN-C transmits precisely spaced pulses from land-based transmitter sites. Receivers can use the pulses from a minimum of three transmitters to determine two-dimensional position and velocity. Precise time is also a byproduct of the received signals. The low frequency system operates at 100 kHz in a band reserved for marine radionavigation. The most widely recognized format is LORAN-C. The excellent stability of the system yields repeatable accuracies of 20–50 m and stratum 1 timing.

In practice, one signal is designated by the receiver as the Master and the others are Secondary signals. The LORAN-C receiver determines location information by measuring the very small difference between the pulse arrival times for each Master-Secondary pair. Because the receiver does not know where the transmitters are located, each time difference mathematically plots along a line that can be described by a

hyperbolic curve. Comparing the curves from the two results, the receiver location is at the intersection of these two curves.

As stated earlier, time is a byproduct of these signals. By knowing the receiver position, multiple time signals can be adjusted to compensate for propagation delays, resulting in very precise time synchronization. The absolute accuracy of the LORAN-C measurement is a function of effects to the signal passing over irregular terrain. These effects are referred to as Additional Secondary Factor (ASF) effects. By itself, because of ASF, LORAN-C is considered a “quarter nautical mile system.”

Today, with the ubiquitous use of satellite location technology, LORAN-C serves as an alternate source of position to provide redundancy for critical positioning systems. Critical timing users such as telecommunication providers, power grids, governments, and financial institutions can also benefit from the redundant source of synchronized time.

The LORAN-C system complements satellite systems, and is a fully independent source of position, velocity, and time, especially where line-of-sight is restricted. Also, satellite systems can be used to calibrate LORAN-C to compensate for ASFs.

While LORAN-C offers high-accuracy time synchronization, the 100 kHz carrier frequency is considered susceptible to interference from coronal discharges in and around high-voltage power stations, making it unsuitable for a majority of electric utility applications. In addition, its limited transmitter sites reduce its coverage to major portions of North America and some coastal areas of Asia and Europe, see Fig. 26.

B. Internet Time Synchronization Sources

1) Internet Time Synchronization [8]

Computers and IEDs connected to the Internet can be synchronized to an Internet timeserver. The process is fast and easy. All that is needed is an active Internet connection and client software. Internet timeservers use several standard timing protocols defined in a series of RFC (Request for Comments) documents. The three major Internet Time Service protocols are the Time Protocol, the Daytime Protocol, and the Network Time Protocol (NTP). Timeservers are continually “listening” for timing requests sent using any of these three protocols. When the timeserver receives a request, it sends the time to the requesting computer or IED in the appropriate format.

The protocol that is used depends on the type of client software used. Most client software requests that the time be sent using either the Daytime Protocol or NTP. Client software programs that use the Simple Network Time Protocol (SNTP) make the same timing request as an NTP client but do less processing and provide less accuracy. Table IX summarizes the protocols and their port assignments.

Software programs are available that provide a method for synchronizing the clock of a client computer/IED using messages transmitted over the Internet from a remote timeserver. The principles are appropriate for other types of connections, e.g., a dial-up telephone modem connection, provided that the delay through the network connecting them is symmetrical on average.

All synchronization algorithms start from the same basic data—the measured time difference between the local machine and the distant server and the network portion of the round-trip delay between the two systems. Delays in the distant timeserver are usually not a problem; either they are small enough to be ignored, or they are measured by the time server and removed by the client. These data are processed to develop a correction to the reading of the local clock. The usual approach is to use the measured time difference after it has been corrected by subtracting one-half of the round-trip delay. This model is based on the assumption that the transmission delay through the network is symmetrical so that the one-way delay is one-half of the measured round-trip value. This corrected value may be used to discipline the local clock directly, it may be combined with similar data from other servers to detect gross deviant points that are statistically irrelevant, or it may be used to compute a weighted average time difference that is then used to steer the local clock.

The steering corrections are made in either time steps, which adjust the local clock by a fixed amount, or frequency steps, which adjust the effective frequency of the local clock oscillator and thereby slow the time.

This approach is better suited to computers and servers that can run software programs. Protection and control IEDs are more likely to operate on imbedded software (firmware) that would require special or unique code to perform the time synchronization function.

TABLE IX
INTERNET TIME PROTOCOLS

Name	Document	Format	Port Assignments
Time Protocol	RFC-868	Unformatted 32-bit binary number contains time in UTC seconds since January 1, 1900.	Port 37tcp/ip, udp/ip
Daytime Protocol	RFC-867	Exact format not specified in standard. The only requirement is that time code is sent as standard ASCII characters.	Port 13tcp/ip, udp/ip
Network Time Protocol (NTP)	RFC-1305	The server provides a data packet that includes a 64-bit timestamp containing the time in UTC seconds since January 1, 1900 with a resolution of 200 picoseconds. NTP provides accuracy of 1 to 50 ms. NTP client software normally runs continuously and gets periodic updates from the server.	Port 123udp/ip
Simple Network Time Protocol (SNTP)	RFC-2030	The data packet sent by the server is the same as NTP, but the client software does less processing and provides less accuracy.	Port 123udp/ip

Reported accuracies [8] using this type of approach are as low as 1 ms. More frequent synchronization is required to maintain this level of accuracy, which adds to the communications burden on the computer, server, or IED. Variations in network loading can cause variations in round-trip delay that increase the potential for error. Unbalanced network traffic loading, as well as physical routing differences, cause communications delay asymmetry, which is also a source of additional error. Synchronizing a clock via the Internet so that it is correct to the nearest second is easily achievable. Synchronizing the clock within several milliseconds is realistic but difficult.

a) IEEE Standard 1588

The IEEE Standard 1588, “Standard for a Precision Clock Synchronization Protocol for Networked Measurement and Control Systems,” is a new standard to allow timing accuracies better than 1 μ s for devices connected via a network such as Ethernet. At the time of this writing this standard is in commercially available products that have demonstrated this performance. However, it is not presently in widespread use because special hardware is required that permits the sending device to know exactly when the message was sent. Knowing this permits extremely accurate measurement of network propagation delays that are then used to make precise adjustments to the device clock time. The drawback to this approach, however, is that all devices in the network that receive and send messages must have hardware compatible with this standard. For more information see <http://ieee1588.nist.gov/>.

b) Dial-up modem time synchronization [9]

Computers and IEDs that are not connected to the Internet can be synchronized using a standard telephone line and an analog modem. The service that provides this function is called the Automated Computer Time Service (ACTS). ACTS requires only a computer, an analog modem and phone line, and some simple software.

When a computer connects to ACTS by telephone, it receives an ASCII time code. The full time code is transmitted every second. The last character in the time code is an asterisk (*). The asterisk is called the ontime marker (OTM). The time values sent by the time code refer to the arrival time of the OTM. In other words, if the time code says it is 12:45:45, this means it is 12:45:45 when the OTM arrives.

To compensate for the time it takes for the OTM to travel from the ACTS service to the computer, ACTS sends the OTM out early, typically 30 to 45 milliseconds, depending on the service. This delay includes the time that it takes to send the message and OTM at the connected baud rate, and an additional delay to allow for the modem processing delay. ACTS services typically fix a delay based on experiments conducted using a typical modem. The service also restricts the baud rate to 9600 baud or lower. Modems communicating at higher baud rates incur more delay because of data compression and error detection techniques.

Advancing the OTM by a fixed delay provides a reasonable correction to compensate for the actual delay. However, to get the least amount of timing uncertainty, the OTM should be advanced by the amount of the actual path delay. Some ACTS

services can do this by using a loop-back technique to calibrate the path. The loop-back technique works if the user’s computer software echoes the OTM to the source after it is received. Each time the OTM is returned, ACTS measures the amount of time it took for the OTM to go from the source to the user and back. This quantity is the round-trip path delay, which is divided by 2 to get the one-way path delay.

After a loop-back measurement is made, ACTS advances the time by the amount of the one-way path delay. For example, if the one-way path delay is 50.4 milliseconds, ACTS sends the OTM out 50.4 milliseconds early (instead of 45 ms). With a calibrated path, ACTS can set a computer clock with an uncertainty of less than 10 ms.

Keep in mind that ACTS only works with analog modems that use ordinary telephone lines. Digital modems, such as Digital Subscriber Line (DSL) and cable modems, cannot connect to ACTS. Computers and IEDs with digital communications connections are usually connected to the Internet, so they can be synchronized using one of the Internet Time Service protocols.

C. Satellite Time Synchronization Sources

1) Satellite Broadcasts [2] [10]

Satellite broadcast timing offers significant advantages over other timing systems:

- Wide-area coverage
- Only slightly affected by atmospheric and seasonal variations
- Not affected by irregular terrain
- Continuously referenced to a national standard
- Relatively low cost

Satellite broadcasts result in relatively low cost because the satellite system sponsor provides the primary reference and time dissemination system. The principal problem or risk with satellite broadcasts is availability. All satellite broadcast systems have been put up through individual or joint government efforts for purposes other than time dissemination. During crises, the primary purposes take priority, and timing functions may be suspended or intentionally degraded, resulting in reduced accuracy. Satellite systems are expensive to put up and maintain, so in the long term, those using the system for timing purposes are at the mercy of funding provided for the primary function.

The main systems currently in use are GOES, GPS, and GLONASS. Several other potential sources include a GPS-like overlay on INMARSAT satellites and the GALILEO satellite system.

a) GOES

The Geostationary Operational Environmental Satellite (GOES) system’s primary mission is weather monitoring in the western hemisphere. The system consists of two geostationary satellites situated in high earth orbit, approximately 22,000 miles above the earth’s surface. The propagation delays encountered from this long distance can be compensated based on the receiver’s known location, because the distance between the satellite transmitter and earth receiver is fixed. Small dish antennas are generally used with the earth-based

receivers and must be readjusted if the satellites are moved. The radio link suffers some interference problems with land-based mobile communications and outages due to solar eclipses in the spring and fall. The system provides time synchronization referenced to UTC with a base accuracy of 25 μ s, although a more realistic operating accuracy is 100 μ s. Overall, it provides a synchronizing signal that is acceptable for most, but not all, power system timing and time-tagging applications.

The GOES system provides a source of synchronized time code that was popular with electric utilities prior to the advent of the global positioning satellite system. Subsequent to the full implementation of the global positioning satellite system, the use of GOES for time synchronization fell out of favor because of receiver cost and relatively low accuracy. The other disadvantage is that GOES is not universally available because of its relatively stationary position in the western hemisphere.

b) GPS

The Global Positioning System (GPS) is a constellation of 24 Earth-orbiting satellites (24 are in operation and there are several satellites as backups). The U.S. military developed this satellite network as a military navigation system, but soon opened it to everyone. Selective Availability, which limited GPS accuracy, was eliminated in May 2000. The satellites are moving in a low-Earth orbit (12,000 miles above the Earth's surface) with an orbit time of 12 hours.

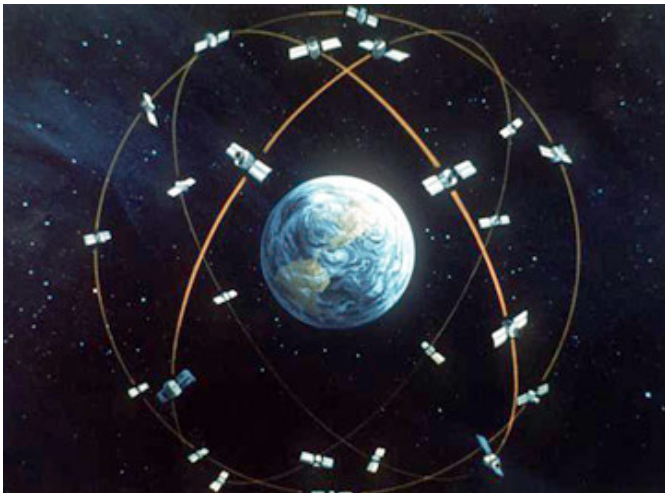

Fig. 27. The Global Positioning System (GPS) is a Constellation of 24 Earth-Orbiting Satellites (Picture Courtesy of Department of Defense)

The U.S. Department of Defense (DoD) designed GPS to be a highly reliable source for navigation throughout the world. With a minimum of four-satellite coverage at all times, even sites with restricted sky view are unlikely to lose signal reception. The 1575 MHz time signal can be received by a simple omni directional antenna. The spread-spectrum technique that is used makes the signal resistant to interference. However, the relatively low signal levels require a very sensitive receiver.

GPS receivers must know where the satellites actually are in order to correct for signal propagation delay. This is relatively easy because the satellites travel in very high and predictable orbits. The GPS receiver stores an almanac that tells it

where every satellite should be at any given time. Gravitational forces of the moon and the sun alter the satellites' orbits very slightly, but the DoD constantly monitors their exact positions and transmits any adjustments to all GPS receivers as part of the satellites' signals.

D. IRIG Time Signal Distribution Techniques

In the simplest form there are three synchronization requirements:

1. Synchronize the clocks of all IEDs in a substation.
In this application the goal is to have all of the IED records in a substation referenced to the same time. It is not as important that this be the exact time, referenced to global time, such as UTC. Either modulated or demodulated IRIG-B, with 1 ms accuracy, is generally suitable for this application.
2. Synchronize the clocks of IEDs in several substations.
For this application it is required that all of the IED records in several stations be within one to a few milliseconds of each other. Either modulated or demodulated IRIG-B is again suitable for this application. The additional requirement is that a common source of synchronized time must be supplied to all stations to create a common time reference.
3. Synchronize power system data sampling across the power system (synchrophasors).

This application currently requires the most stringent synchronization requirements. In this application, IEDs located across the power system need to be synchronized to within 1 μ s or less of each other. Only demodulated IRIG-B is suitable for this application. And additional limitations are placed on the distribution techniques to maintain the microsecond level of accuracy.

When distributing demodulated IRIG-B signals for high-accuracy applications, a networked coaxial connection, directly between the IEDs and the clock source, is preferred, as shown in Fig. 28. The number of devices that can be paralleled across the coaxial depends on the drive capability of the clock output and the impedance of the IED IRIG-B inputs. When long coaxial cable runs are used and the impedance of the IEDs is high, relative to the cable characteristic impedance, then a cable terminator, matching the characteristic impedance of the cable, must be attached to the end of the cable, as shown in Fig. 28. For example, a 50-ohm coaxial cable should be terminated with a 50-ohm termination. Preferably, when the clock has multiple outputs that support the high-accuracy IRIG-B signal, IEDs should be connected to each available clock output to minimize the loading on each clock output and on each IRIG-B distribution cable.

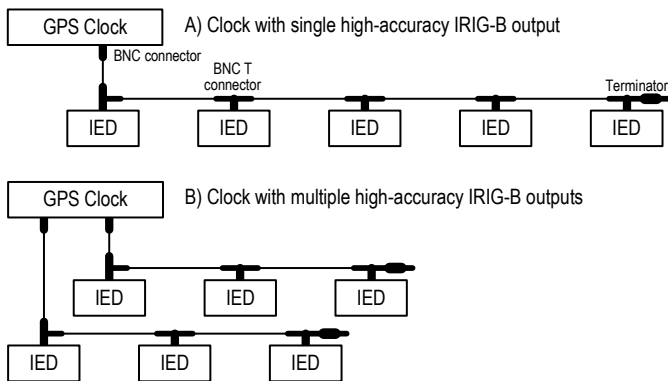

Fig. 28. Preferred High-Accuracy IRIG-B Time Distribution Method

One method used to get around the impedance limitation on the number of IEDs is called series/parallel. In this application, low-input impedance IEDs are connected in series pairs across a parallel connection, as shown in Fig. 29. As can be seen in Fig. 29, it is not easy to implement and cannot be implemented with coaxial cable. This method is not recommended for high-accuracy applications.

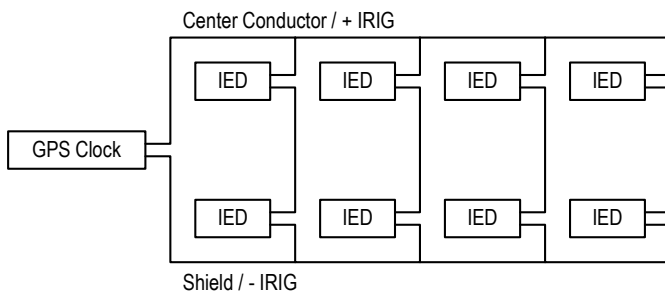

Fig. 29. Series/Parallel Connection

X. REFERENCES

- [1] K. Higgins, D. Miner, C. N. Smith, D. B. Sullivan (2004), "A Walk Through Time," (version 1.2.1). [Online] Available: <http://physics.nist.gov/time> [2005, Aug. 21]. National Institute of Standards and Technology, Gaithersburg, MD.
- [2] National Institute of Standards and Technology (NIST), Division 847, Time and Frequency Division, Boulder, CO; <http://tf.nist.gov/>.
- [3] IEEE Standard PC37.118, Draft 6.0, Dec. 2004, Informative Annex F, "Time and Synchronization Communication."
- [4] North American Electric Reliability Council Report to the NERC Board of Trustees, "Technical Analysis of the August 14, 2003 Blackout: What Happened, Why, and What Did We Learn?" July 13, 2004.
- [5] "Synchronized Phasor Measurement in Protective Relays for Protection, Control, and Analysis of Electric Power Systems," by Gabriel Benmouyal, Armando Guzman, and Edmund O. Schweitzer III, presented at the 29th Annual Western Protective Relay Conference, Oct. 2002.
- [6] IEEE Standard PC37.118, Draft 6.0, Dec. 2004, Informative Annex E.3, "Broadcasts From Terrestrial Sources."
- [7] Megapulse, North Billerica, MA 01862; <http://www.megapulse.com/>.
- [8] IEEE Transactions on Ultrasonics, Ferroelectrics, and Frequency Control, Vol. 16, No. 4, July 1999, "Time Synchronization of the Internet Using an Adaptive Frequency-Locked Loop," by Judah Levine.
- [9] IEEE/ACM Transactions on Networking, Vol. 3, No. 1, Feb. 1995, "An Algorithm to Synchronize the Time of a Computer to Universal Time," by Judah Levine.
- [10] IEEE Standard PC37.118, Draft 6.0, Dec. 2004, Informative Annex E.2, "Broadcasts From Satellites."

XI. BIOGRAPHIES

Ken Behrendt received a Bachelor of Science Degree in Electrical Engineering from Michigan Technological University in 1970. From 1970 to 1994, he was employed at Wisconsin Electric Power Company where he worked in Distribution Planning, Substation Engineering, Distribution Protection, and Transmission Planning and Protection. From April of 1994 to present he has been employed with Schweitzer Engineering Laboratories as a Field Application Engineer, located in New Berlin, Wisconsin. Ken is an IEEE Senior Member and an active member of the IEEE Power System Relay Committee, the US representative on CIGRE Joint Working Group 34/35.11 on Teleprotection, and is a registered Professional Engineer in the state of Wisconsin. Ken has authored and presented several papers at major power system and protective relay conferences.

Ken Fodero is currently the Product Engineering Manager for Schweitzer Engineering Laboratories, Inc., Pullman, Washington. Before coming to work at SEL he was a product manager at Pulsar Technology for four years in Coral Springs, Florida. Prior to Pulsar, Ken worked at RFL Electronics for 15 years; his last position there was Director of Product Planning. He has also worked for Westinghouse Electric, now ABB, as Relay System Technician. Ken is the current chairman of the Communications Subcommittee for IEEE PSRC. He graduated from RETS in New Jersey as an Electronic Technologist.